

2 STYLE AND DIMENSION OF REEL

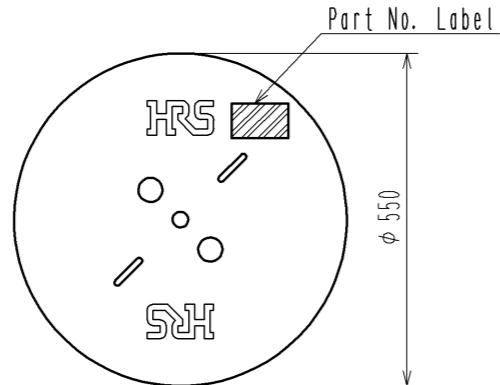

Detail of part No. Label

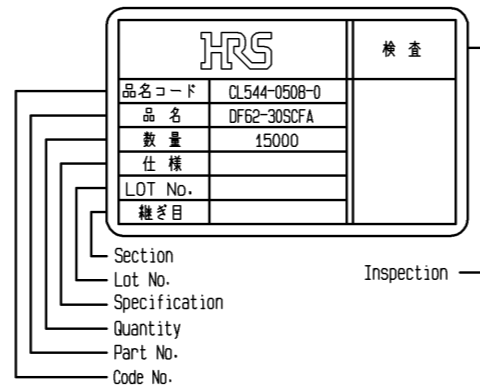

- NOTE 1. 1RL:15000 CONTACTS.
 2. STYLE OF REEL AND BOX ARE SHOWN IN FIGURE.
 3. A MAXIMUM OF 5 REELS ARE PACKED UP IN ONE BOX.
 4. PLEASE BE SURE TO CHECK THE FORM OF CRIMPING USING A CABLE. WHEN YOU ADJUST APPLICATOR.
 5. TIN PLATING AREA.
 6. GOLD PLATING AREA.
 7. THE DIMENSIONS IN PARENTHESIS ARE FOR REFERENCE.

NO.	MATERIAL	FINISH . REMARKS	NO.	MATERIAL	FINISH . REMARKS
1	PHOSPHOR BRONZE				CONTACT AREA : GOLD PLATING 0.2 μm MIN CARRIER/BARREL AREA : TIN PLATING 1 μm MIN OTHERS : NICKEL PLATING 0.5 μm MIN
UNITS mm		SCALE 10 : 1	COUNT △	DESCRIPTION OF REVISIONS	
APPROVED : KI. AKIYAMA		12.01.20	DRAWING NO. EDC3-339878-00		
CHECED : MN. KENJO		12.01.20	PART NO. DF62-30SCFA		
DESIGNED : TO. HORII		12.01.20	CODE NO. CL544-0508-0-00		
DRAWN : TO. HORII		12.01.20	△ 1/1		