

Oct.1.2018 Copyright 2018 HIROSE ELECTRIC CO., LTD. All Rights Reserved.
 In case that the application demands a high level of reliability, such as automotive,
 please contact a company representative for further information.

1		2			3			4		
COUNT	DESCRIPTION OF REVISIONS	BY	CHKD	DATE	COUNT	DESCRIPTION OF REVISIONS	BY	CHKD	DATE	
△				..	△				..	
△					△				..	
△					△				..	

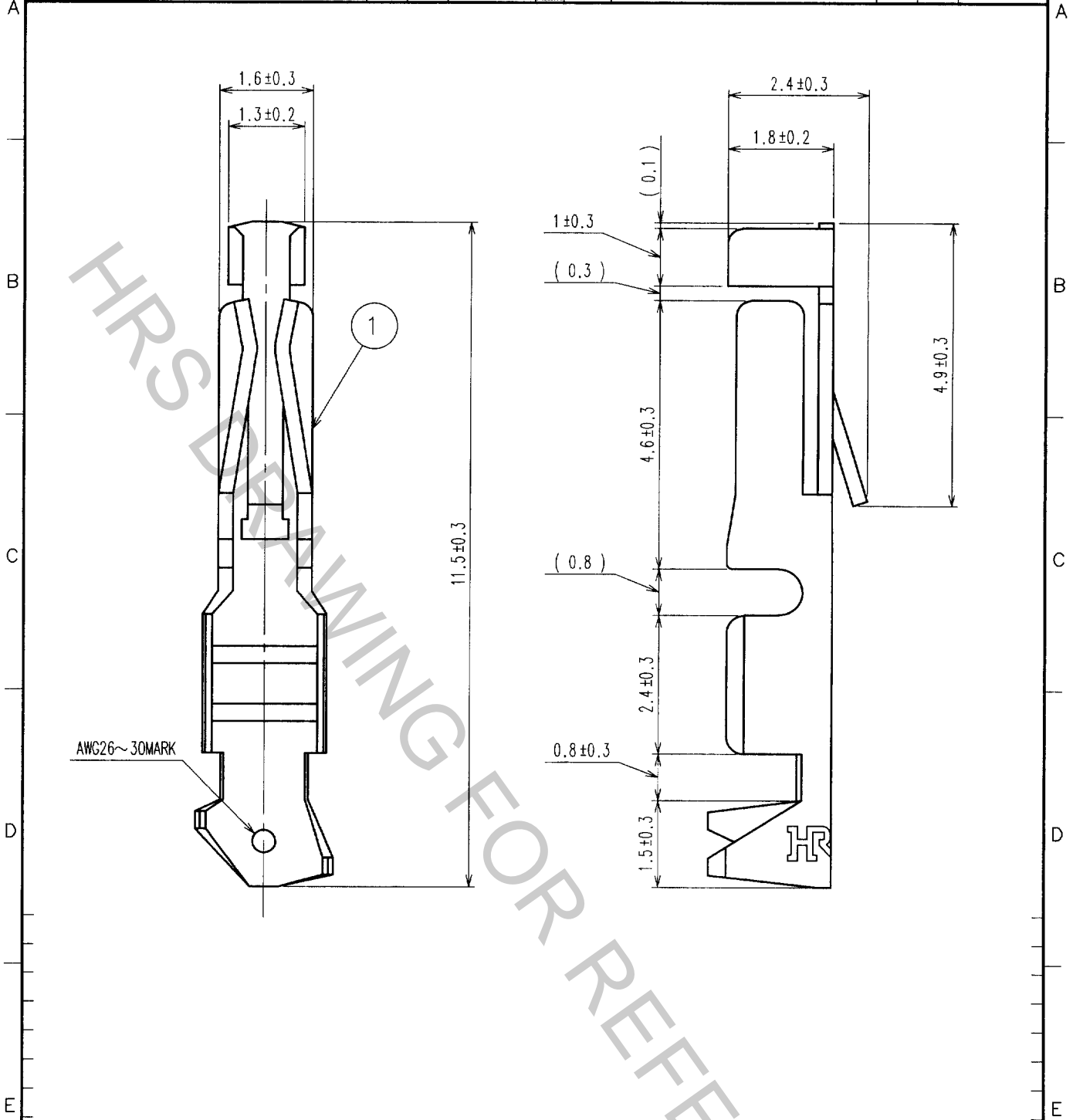

NO.	MATERIAL	FINISH, REMARKS	NO.	MATERIAL	FINISH, REMARKS
1	PHOSPHOR BRONZE	CONTACT AREA: GOLD PLATED(0.2μm) OVER NICKEL THE OTHER AREA: NICKEL PLATED			

CODE NO. (OLD)	DRAWN	DESIGNED	CHECKED	APPROVED	RELEASED
	<i>[Signature]</i>	<i>[Signature]</i>	<i>[Signature]</i>	<i>[Signature]</i>	
	02.06.17	02.06.17	02.06.17	02.06.17	

	DRAWING NO. EDC4-017876	PART NO. HIF3-2630SCC
SCALE 10 : 1	 HIROSE ELECTRIC CO., LTD.	CODE NO. CL613-0003-4
UNITS mm		1/1

TO
PCK

