

Oct.1.2018 Copyright 2018 HIROSE ELECTRIC CO., LTD. All Rights Reserved.
 In case that the application demands a high level of reliability, such as automotive,
 please contact a company representative for further information.

1		2			3			4		
COUNT	DESCRIPTION OF REVISIONS	BY	CHKD	DATE	COUNT	DESCRIPTION OF REVISIONS	BY	CHKD	DATE	
1	DIS-C-000585	T.K	E.K	07.07.27						

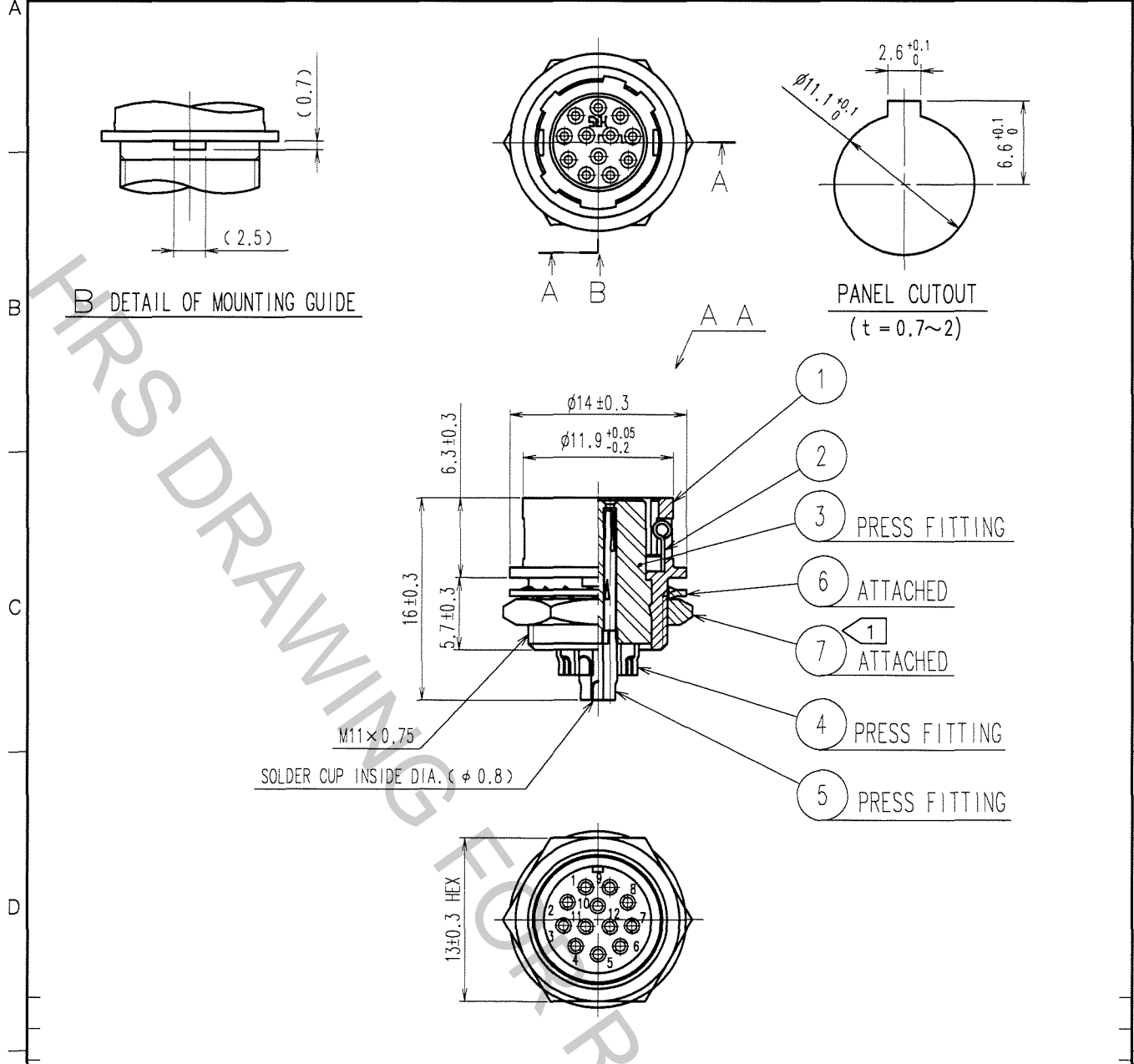

NOTE ① THE RECOMMENDED CLAMP TORQUE OF REF. NO. ⑦ TO BE 2 N · m.
 LOCTITE 242, HENKEL JAPAN OR EQUIVALENT IS RECOMMENDED TO
 PREVENT REF. NO. ⑦ FROM LOOSENING.

NO.	MATERIAL	FINISH, REMARKS	NO.	MATERIAL	FINISH, REMARKS
3	POLYAMIDE	(BLACK) UL94V-0	7	BRASS	NICKEL PLATING
2	STAINLESS STEEL		6	PHOSPHOR BRONZE	NICKEL PLATING
1	ZINC ALLOY	MATTE FINISH NICKEL PLATED	5	PHOSPHOR BRONZE	SILVER PLATING 2μ m min.
			4	PHOSPHOR BRONZE	

CODE NO. (OLD) CL	DRAWN D.MATSUNE '05 10 01	DESIGNED D.MATSUNE '05 10 01	CHECKED E.KUNII '05 10 03	APPROVED M.SATO '05 10 14	RELEASED
----------------------	---------------------------------	------------------------------------	---------------------------------	---------------------------------	----------

TO
R

	DRAWING NO. EDC4-010387-71	PART NO. HR10A-10R-12S(71)
		CODE NO. CL110-0403-2-71