

NO.	DESCRIPTION OF REVISIONS	BY	CHKD	DATE	COUNT	DESCRIPTION OF REVISIONS	BY	CHKD	DATE

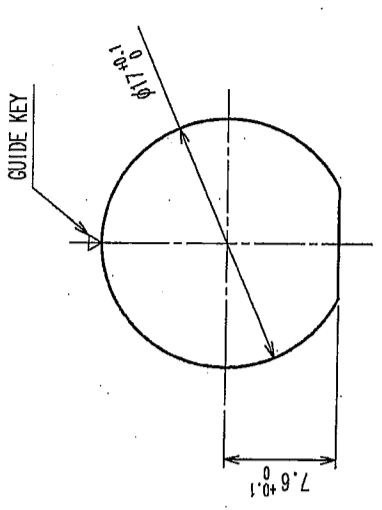
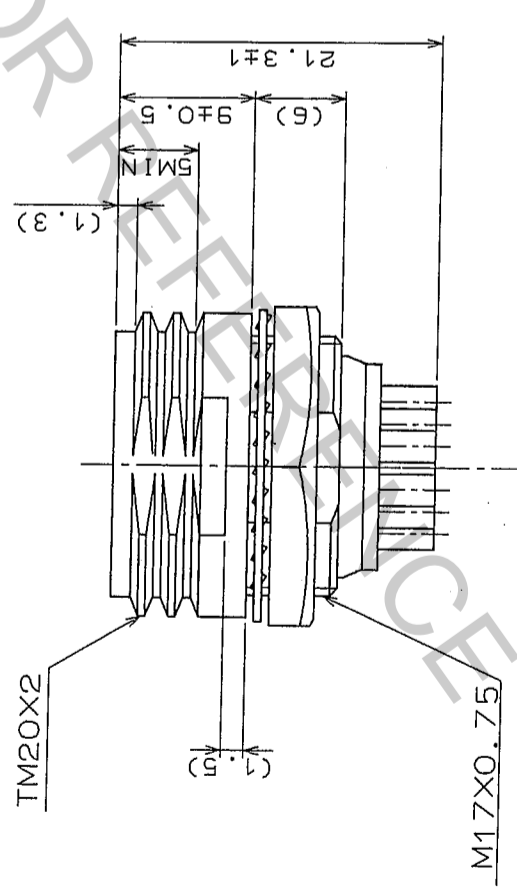
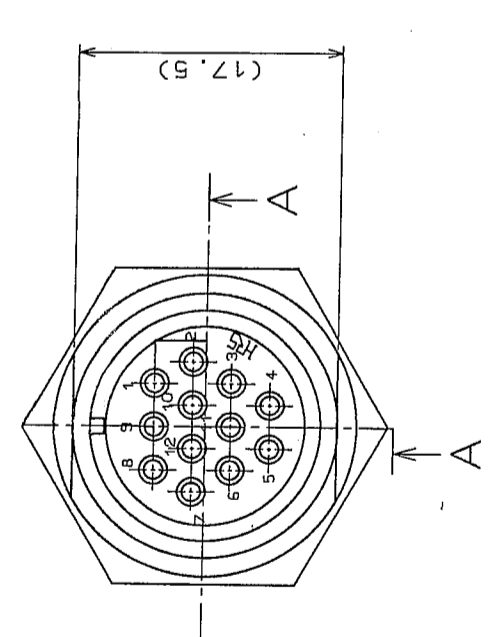
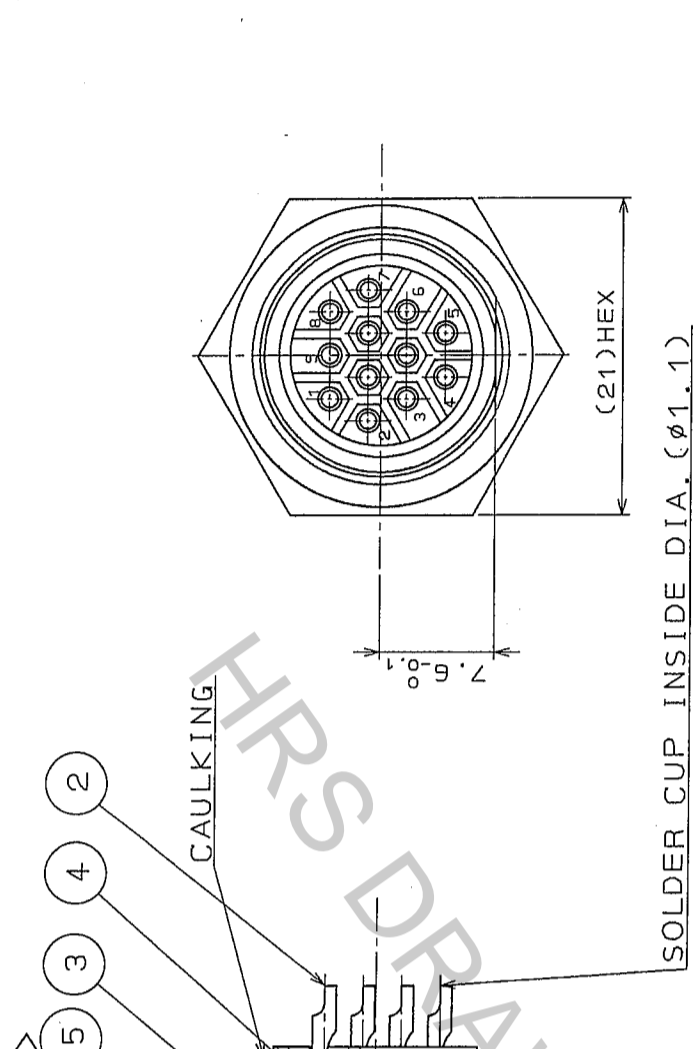

PANEL CUTOUT  
 t:0.5~2

NOTE [1] THE RECOMMENDED CLAMP TORQUE OF REF.NO. ⑤ : 3 TO 4 N · m.  
 LOCTITE 242, LOCTITE OR EQUIVALENT IS RECOMMENDED TO  
 PREVENT REF NO. ⑤ FROM LOOSENING.

3	DIALLYL PHTHALATE (BLACK)	UL 94V-0	6	PHOSPHOR BRONZE	NICKEL PLATING
2	COPPER ALLOY	SILVER PLATING 5μm min.	5	BRASS	NICKEL PLATING
1	ZINC ALLOY	MATTE FINISH CHROME PLATE	4	DIALLYL PHTHALATE (BLACK)	UL 94V-0
NO.	MATERIAL	FINISH . REMARKS	NO.	MATERIAL	FINISH . REMARKS
CODE NO. (OLD)		DRAWN	DESIGNED	CHECKED	APPROVED
		Y. Yamada	Y. Yamada	H. Zembu	M. Sato
		05.09.12	05.09.12	05.09.17	05.09.20
		PART NO.		RELEASED	
		EDC3-007495-71		RM15TRD-12S (71)	
SCALE		DRAWING NO.		PART NO.	
2 : 1		EDC3-007495-71		RM15TRD-12S (71)	
UNITS		DRAWING NO.		CODE NO.	
mm		EDC3-007495-71		CL109-0663-3-71	
		HRS HIROSE ELECTRIC CO., LTD.			

TO	
R	