

PART NAME: KNOB SCALE: 1:1 DATE: 11/1/16 DR. BY JAM

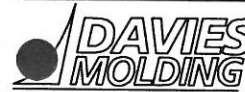

DESIGNERS & MANUFACTURERS
OF KNOBS, HANDLES, CASES &
CUSTOM PLASTIC COMPONENTS

P/N 2820BM-CU

THIS DRAWING IS THE PROPERTY OF DAVIES MOLDING COMPANY, IS SUBMITTED SOLELY AS A DESIGN OR ENGINEERING PROJECT.
WE ACCEPT NO RESPONSIBILITY WHATSOEVER FOR THE PRACTICAL APPLICATION OF THE PIECES MADE TO THIS DESIGN.

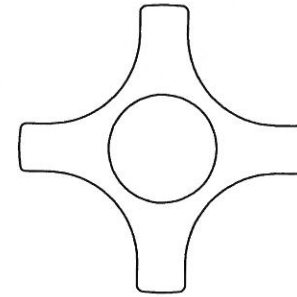

| | THREAD | A | B | C | D |
|--------|-----------|----|----|----|----|
| 2820BM | M6 X 1 | 38 | 25 | 16 | 12 |
| 2820CQ | M8 X 1.25 | 38 | 25 | 16 | 12 |

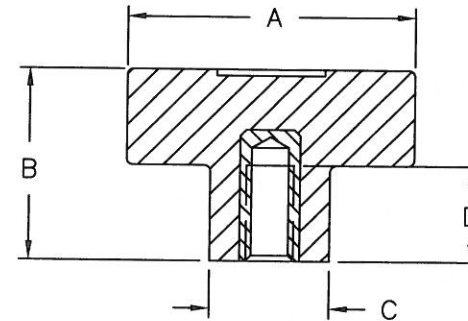

THREADED INTERNAL INSERT

| | THREAD | A | B | C | D |
|--------|-----------|----|----|----|----|
| 2820CR | M6 X 1 | 38 | 25 | 16 | 20 |
| 2820CS | M6 X 1 | 38 | 25 | 16 | 30 |
| 2820CT | M8 X 1.25 | 38 | 25 | 16 | 20 |
| 2820CU | M8 X 1.25 | 38 | 25 | 16 | 30 |

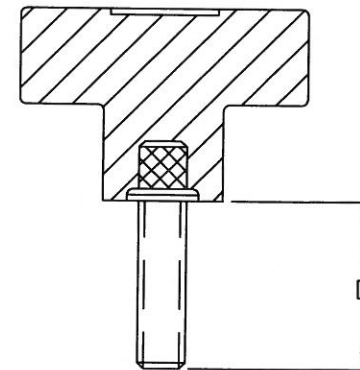

THREADED STUD

KNOB MATERIAL: PHENOLIC
COLOR: BLACK

INSERT MATERIAL: INTERNAL INSERTS ARE BRASS,
PROJECTING STUDS ARE ZINC PLATED STEEL

| TOLERANCES: UNLESS OTHERWISE SPECIFIED | DO NOT SCALE DRAWING | | | |
|---|----------------------------------|---------|--|--|
| | MM: X.XX ± 0.15MM X.X ± 0.4MM | | | |
| | ANG. ± 1° | CHANGES | | |