

Approximate Performance in Laboratory Tests

Tensile Strength: 32000 N
Direct Torque: 50 Nm
Body Torque: 11 Nm
Shear Strength: 5000 N

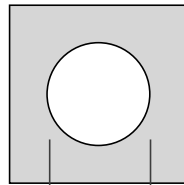

12 - 12.1

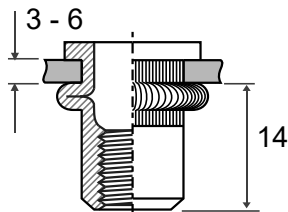

3 - 6

14

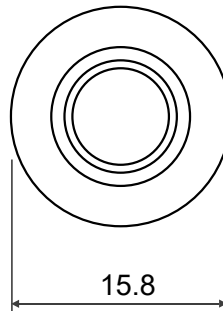

15.8

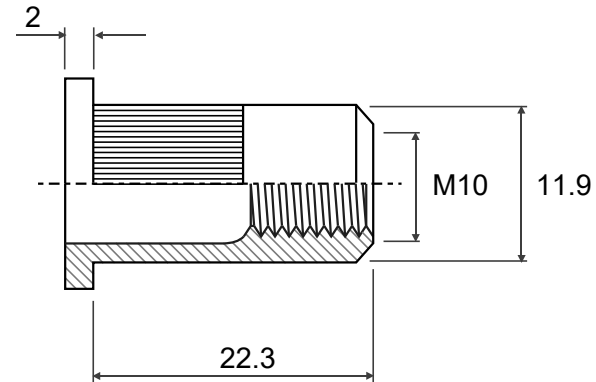

2

M10

11.9

22.3

	Material		Customer Part No.	
	Finish		Web Ref No	