

Approximate Performance in Laboratory Tests

Direct Torque: 8.5 Nm
Tensile Strength: 11500 N
Shear Strength: 2000 N

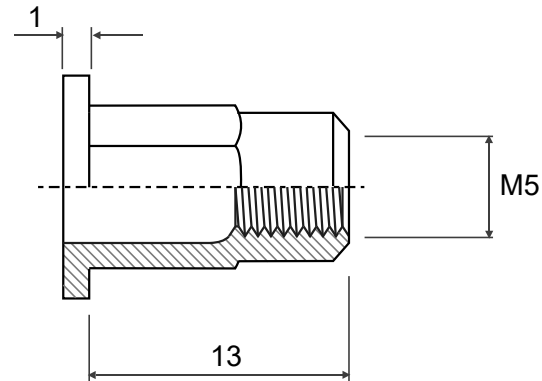
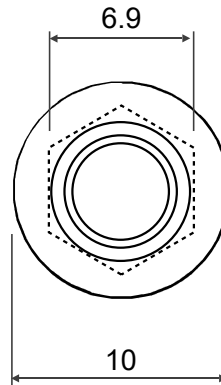
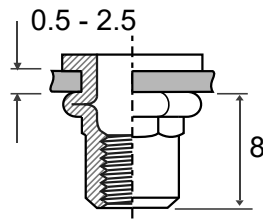

	Material		Customer Part No.	
	Finish		Web Ref No	