

PART NAME: STANDOFF

SCALE: 2:1

DATE: 12/9/16

DR. BY: JAM



P/N:

SH1006

THIS DRAWING IS THE PROPERTY OF DAVIES MOLDING COMPANY, IS SUBMITTED SOLELY AS A DESIGN OR ENGINEERING PROJECT. WE ACCEPT NO RESPONSIBILITY WHATSOEVER FOR THE PRACTICAL APPLICATION OF THE PIECES MADE TO THIS DESIGN.

DAVIES PART #	THREAD	A	B	C	D
SH1006-A	M5	12	20	4.2	8
SH1006-B	M5	12	25	4.2	8
SH1006-C	M5	12	30	7.5	8
SH1006-D	M5	12	35	7.5	8
SH1006-E	M5	12	40	7.5	8
SH1006-F	M5	12	45	7.5	8
SH1006-G	M5	12	50	7.5	8
SH1006-H	M5	12	55	7.5	8
SH1006-J	M5	12	60	7.5	8
SH1006-K	M5	12	65	7.5	8
SH1006-L	M5	12	70	7.5	8
SH1006-M	M5	12	75	7.5	8
SH1006-N	M5	12	80	7.5	8
SH1006-P	M5	12	85	7.5	8
SH1006-Q	M5	12	90	7.5	8
SH1006-R	M5	12	95	7.5	8
SH1006-S	M5	12	100	7.5	8
SH1006-T	M5	12	105	7.5	8

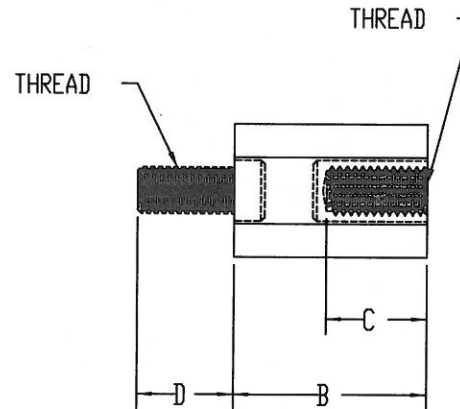
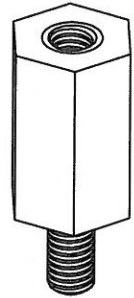

MATERIAL: NYLON  
COLOR: BLACK

STUD: STEEL  
INTERNAL INSERT: BRASS

A	UPDATED TABLE	JAM	10/11/18
CHANGES			