

PART NAME: KNOB SCALE: 1:1 DATE: 11/1/16 DR. BY JAM

THIS DRAWING IS THE PROPERTY OF DAVIES MOLDING COMPANY, IS SUBMITTED SOLELY AS A DESIGN OR ENGINEERING PROJECT. WE ACCEPT NO RESPONSIBILITY WHATSOEVER FOR THE PRACTICAL APPLICATION OF THE PIECES MADE TO THIS DESIGN.



DESIGNERS & MANUFACTURERS OF KNOBS, HANDLES, CASES & CUSTOM PLASTIC COMPONENTS

P/N 3000QJ-QN



	THREAD	A	B	C	D
3000QJ	M8 X 1.25	45	20	19	12
3000QK	M10 X 1.5	45	20	19	15



THREADED INTERNAL INSERT

	THREAD	A	B	C	D
3000QL	M8 X 1.25	45	20	19	20
3000QM	M8 X 1.25	45	20	19	30
3000QN	M10 X 1.5	45	20	19	20
3000QP	M10 X 1.5	45	20	19	30

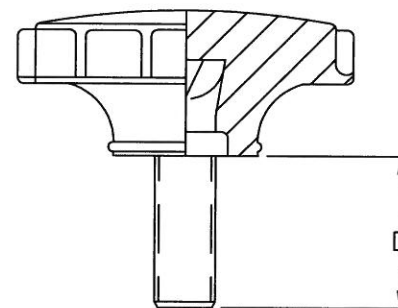

THREADED STUD

KNOB MATERIAL: PHENOLIC  
COLOR: BLACK

INSERT MATERIAL: INTERNAL INSERTS ARE BRASS,  
PROJECTING STUDS ARE ZINC PLATED STEEL

TOLERANCES: UNLESS OTHERWISE SPECIFIED	DO NOT SCALE DRAWING			
	MM: X.XX ± 0.15MM X.X ± 0.4MM			
	ANG. ± 1'	CHANGES		