

PART NAME: KNOB SCALE: 1:1 DATE: 11/1/16 DR. BY JAM

THIS DRAWING IS THE PROPERTY OF DAVIES MOLDING COMPANY, IS SUBMITTED SOLELY AS A DESIGN OR ENGINEERING PROJECT. WE ACCEPT NO RESPONSIBILITY WHATSOEVER FOR THE PRACTICAL APPLICATION OF THE PIECES MADE TO THIS DESIGN.

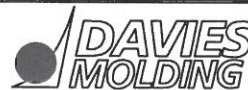

DESIGNERS & MANUFACTURERS OF KNOBS, HANDLES, CASES & CUSTOM PLASTIC COMPONENTS

P/N 3050FQ-FV

	THREAD	A	B	C	D
3050FQ	M8 X 1.25	45	24	25	12
3050FR	M10 X 1.5	45	24	25	15

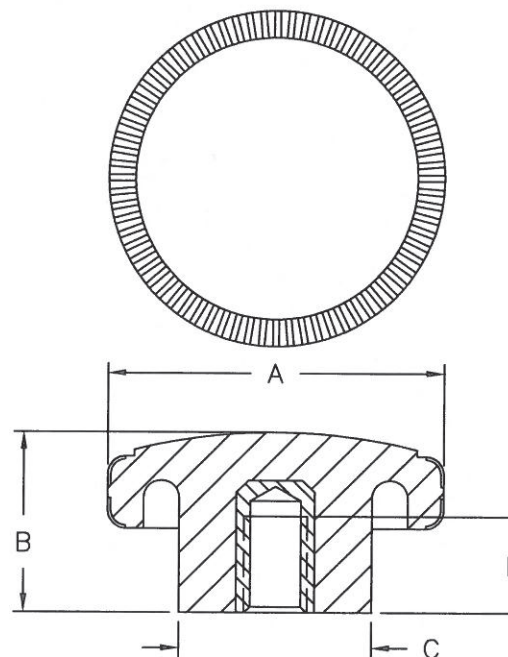

THREADED INTERNAL INSERT

	THREAD	A	B	C	D
3050FS	M8 X 1.25	45	24	25	20
3050FT	M8 X 1.25	45	24	25	30
3050FX	M10 X 1.5	45	24	25	20
3050FV	M10 X 1.5	45	24	25	30

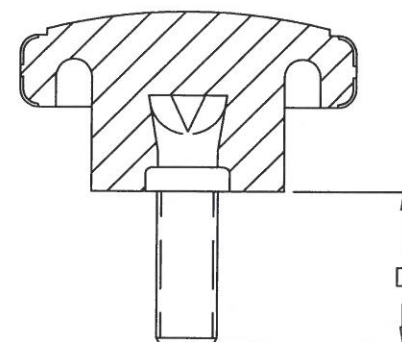

THREADED STUD

KNOB MATERIAL: PHENOLIC
COLOR: BLACK

INSERT MATERIAL: INTERNAL INSERTS ARE BRASS,
PROJECTING STUDS ARE ZINC PLATED STEEL

TOLERANCES: UNLESS OTHERWISE SPECIFIED	DO NOT SCALE DRAWING			
	MM: X.XX ± 0.15MM X.X ± 0.4MM			
	ANG. ± 1°	CHANGES		