

PART NAME: KNOB SCALE: 1:1 DATE: 11/1/16 DR. BY JAM

THIS DRAWING IS THE PROPERTY OF DAVIES MOLDING COMPANY, IS SUBMITTED SOLELY AS A DESIGN OR ENGINEERING PROJECT. WE ACCEPT NO RESPONSIBILITY WHATSOEVER FOR THE PRACTICAL APPLICATION OF THE PIECES MADE TO THIS DESIGN.



DESIGNERS & MANUFACTURERS OF KNOBS, HANDLES, CASES & CUSTOM PLASTIC COMPONENTS

P/N 2715BB-BL

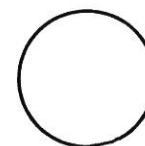

	THREAD	A	B	C	D
2715BJ	M5 X 0.8	18	14	11	10
2715BK	M5 X 0.8	18	14	11	20
2715BL	M6 X 1	18	14	11	20
2715BB	M6 X 1	18	14	11	30

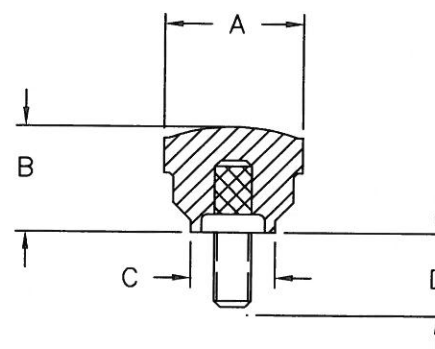

THREADED STUD

KNOB MATERIAL: NYLON
COLOR: BLACK

INSERT MATERIAL: INTERNAL INSERTS ARE BRASS,
PROJECTING STUDS ARE ZINC PLATED STEEL

TOLERANCES: UNLESS OTHERWISE SPECIFIED	DO NOT SCALE DRAWING			
	MM: X.XX ± 0.15MM X.X ± 0.4MM			
	ANG. ± 1°	CHANGES		