

PART NAME: KNOB SCALE: 1:1 DATE: 11/1/16 DR. BY JAM

THIS DRAWING IS THE PROPERTY OF DAVIES MOLDING COMPANY, IS SUBMITTED SOLELY AS A DESIGN OR ENGINEERING PROJECT. WE ACCEPT NO RESPONSIBILITY WHATSOEVER FOR THE PRACTICAL APPLICATION OF THE PIECES MADE TO THIS DESIGN.

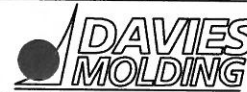

DESIGNERS & MANUFACTURERS OF KNOBS, HANDLES, CASES & CUSTOM PLASTIC COMPONENTS

P/N 2837BE-DX

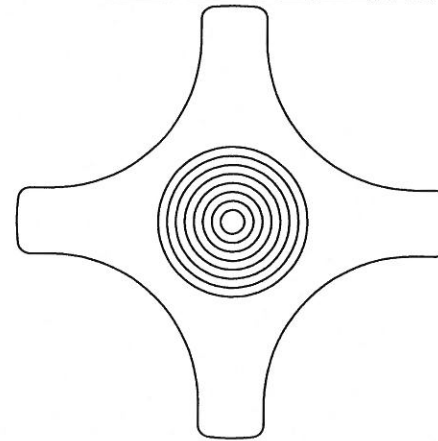

	THREAD	A	B	C	D
2837BE	M8 X 1.25	57	25	25	12
2837DT	M10 X 1.5	57	25	25	15

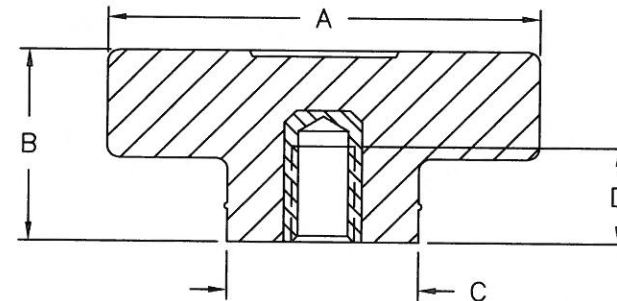

THREADED INTERNAL INSERT

	THREAD	A	B	C	D
2837DU	M8 X 1.25	57	25	25	20
2837DV	M8 X 1.25	57	25	25	30
2837DW	M10 X 1.5	57	25	25	20
2837DX	M10 X 1.5	57	25	25	30

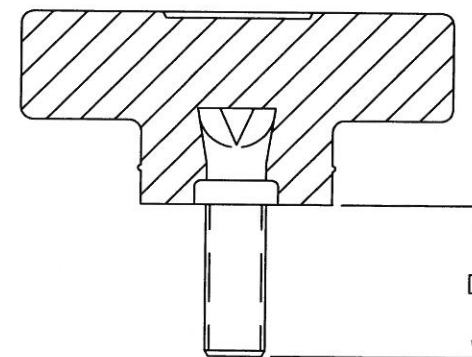

THREADED STUD

KNOB MATERIAL: 20% TALC-FILLED POLYPROPYLENE
COLOR: BLACK

INSERT MATERIAL: INTERNAL INSERTS ARE BRASS,
PROJECTING STUDS ARE ZINC PLATED STEEL

TOLERANCES: UNLESS OTHERWISE SPECIFIED	DO NOT SCALE DRAWING			
	MM: X.XX ± 0.15MM X.X ± 0.4MM			
	ANG. ± 1°	CHANGES		