

NOTES:

1. FINISHED CABLE ASSEMBLY TO BE COILED
2. OVERMOLD BOOT MATERIAL: PVC, BLACK
3. ELECTRICAL TEST: 100% CONTINUITY
4. ALL DIMENSIONS ARE REFERENCE ONLY EXCEPT WHEN NOTED WITH TOLERANCE

ASS'Y P/N	NO. OF POS.
CARA62802PXXX84	2
CARA62803PXXX84	3
CARA62804PXXX84	4
CARA62805PXXX84	5
CARA62806PXXX84	6
CARA6280XPXXX84	

ASS'Y P/N	"X" DIM.
CARA6280XP03984	3 FT. 3 1/2 IN. ± 2 IN. [1M]
CARA6280XP07984	6 FT. 7 IN. ± 2 IN. [2M]
CARA6280XP19784	16 FT. 5 IN. ± 4 IN. [5M]
CARA6280XP39484	32 FT. 9 3/4 IN. ± 8 IN. [10M]
CARA6280XPXXX84	

CABLE LENGTH IN "INCHES"
NO. OF POSITIONS

CABLE LENGTH IN "INCHES"
NO. OF POSITIONS

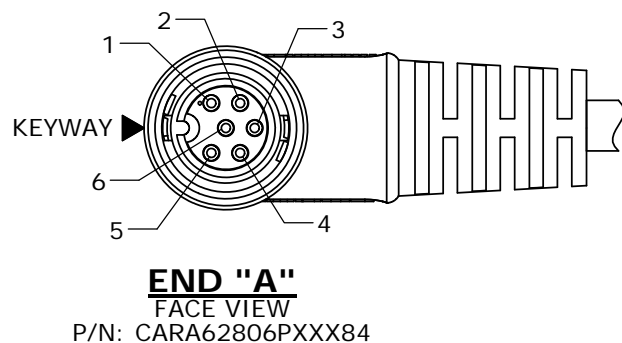
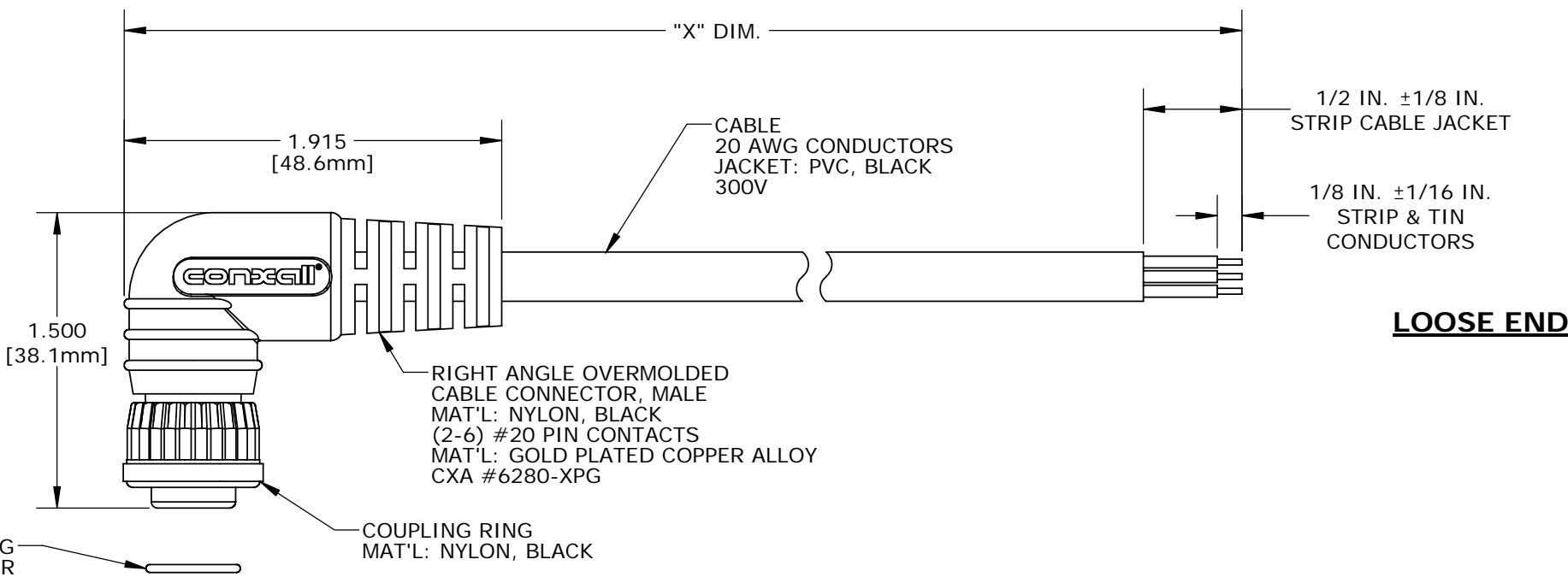
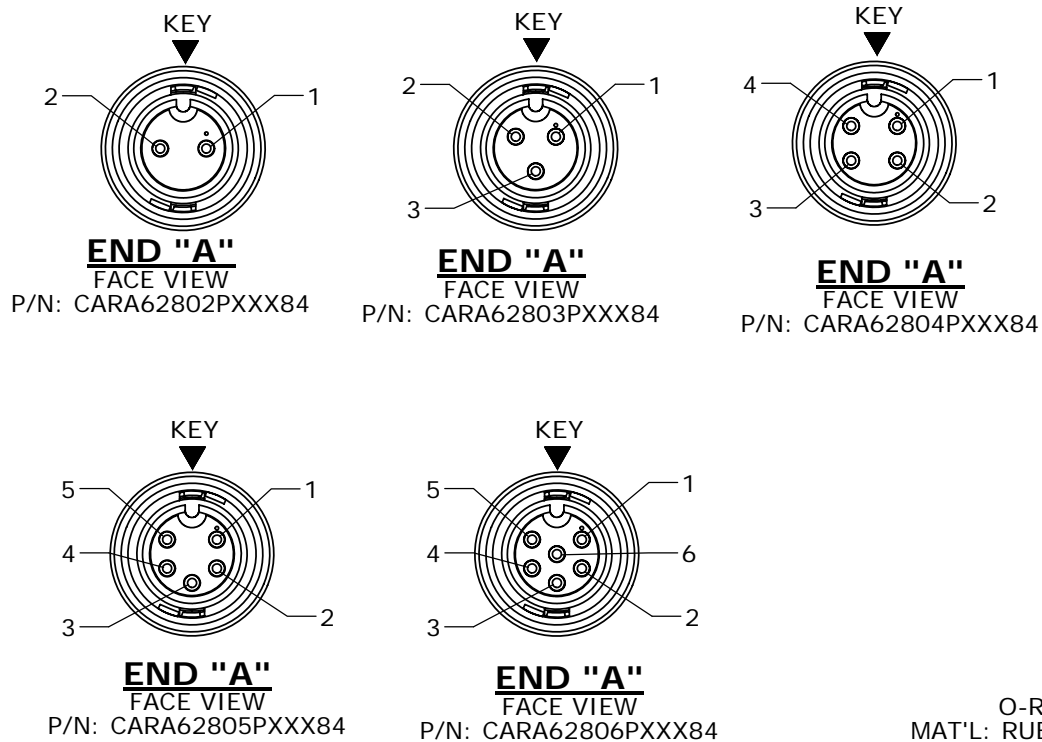

CUSTOMER PRINT

PART NUMBER: CARA6280XPXXX84

ASSY P/N	CABLE	COLOR CODE ENDS "A"					
CARA62802PXXX84	2/20 AWG O.D. 0.215 REF	COLOR CODE					
		POS. 1	POS. 2				
CARA62803PXXX84	3/20 AWG O.D. 0.220 REF	WIRE COLOR CODE					
		POS. 1	POS. 2	POS. 3			
		BLK	WHT	GRN			
CARA62804PXXX84	4/20 AWG O.D. 0.235 REF	WIRE COLOR CODE					
		POS. 1	POS. 2	POS. 3	POS. 4		
		BLK	WHT	GRN	RED		
CARA62805PXXX84	5/20 AWG O.D. 0.255 REF	WIRE COLOR CODE					
		POS. 1	POS. 2	POS. 3	POS. 4	POS. 5	
		BLK	WHT	GRN	RED	BLU	
CARA62806PXXX84	6/20 AWG O.D. 0.275 REF	WIRE COLOR CODE					
		POS. 1	POS. 2	POS. 3	POS. 4	POS. 5	POS. 6
		BLK	WHT	GRN	RED	BLU	VIO

CUSTOMER APPROVAL

THIS DOCUMENT CONTAINS CONFIDENTIAL INFORMATION PROPRIETARY TO CONXALL CORPORATION. ANY REPRODUCTION, DISCLOSURE, OR USE OF THIS DOCUMENT / INFORMATION IS EXPRESSLY PROHIBITED UNLESS AUTHORIZED IN WRITING BY CONXALL CORPORATION.

APPROVED BY: _____

DATE: _____

DIMENSIONS IN BRACKET [] ARE METRIC.

RoHS COMPLIANT

REV.	INIT.	DATE	DESCRIPTION
A	AN	02-26-18	DRAWING CREATED PER DOR 17-8167JS
ALL INFORMATION ILLUSTRATED IS THE PROPERTY OF "CONXALL CORPORATION". UNAUTHORIZED DUPLICATION OR DISTRIBUTION OF THIS DOCUMENT IS PROHIBITED.			ORIG. DRAWN BY: AN DATE: 02-26-18 CHECKED BY:
ALL UNITS ARE IN FEET, INCHES, FRACTION OF INCHES AND DECIMALS.			APPROVED BY: _____ TITLE: CABLE ASSEMBLY (2-6) #20 CONTACTS, MALE MINI-CON-X, RIGHT ANGLE STANDARD PRODUCT CUSTOMER:
FILE:	CARA6280XPXXX84	DIRECTORY:	SLW
- CRITICAL CHARACTERISTIC FLAG PER SPEC. XXXX			PART NUMBER: CARA6280XPXXX84 REV: A



601 E. WILDWOOD VILLA PARK, IL 60181