

CUSTOMER PRINT

PART NUMBER: CARA6280XSXXX84

- NOTES:
1. FINISHED CABLE ASSEMBLY TO BE COILED.
 2. OVERMOLD BOOT MATERIAL: PVC, BLACK.
 3. ELECTRICAL TEST: 100% CONTINUITY
 4. ALL DIMENSIONS ARE REFERENCE ONLY EXCEPT WHEN NOTED WITH TOLERANCE.

ASS'Y P/N	NO. OF POS.
CARA62802SXXX84	2
CARA62803SXXX84	3
CARA62804SXXX84	4
CARA62805SXXX84	5
CARA62806SXXX84	6
CARA62807SXXX84	7
CARA62808SXXX84	8
CARA6280XSXXX84	

ASS'Y P/N	"X" DIM.
CARA6280XS03984	3 FT. 3 1/2 IN. ± 2 IN. [1M]
CARA6280XS07984	6 FT. 7 IN. ± 2 IN. [2M]
CARA6280XS19784	16 FT. 5 IN. ± 4 IN. [5M]
CARA6280XS39484	32 FT. 9 3/4 IN. ± 8 IN. [10M]
CARA6280XSXXX84	

CABLE LENGTH IN "INCHES"
NO. OF POSITIONS

CABLE LENGTH IN "INCHES"
NO. OF POSITIONS

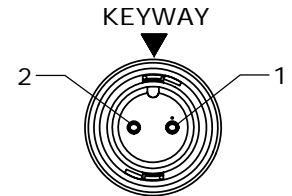

FACE VIEW
P/N: CARA62802SXXX84

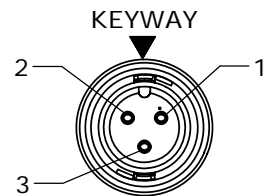

FACE VIEW
P/N: CARA62803SXXX84

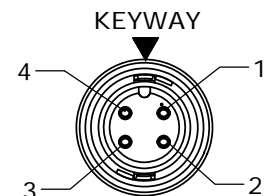

FACE VIEW
P/N: CARA62804SXXX84

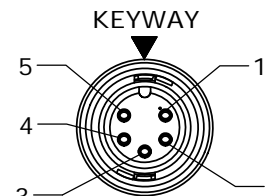

FACE VIEW
P/N: CARA62805SXXX84

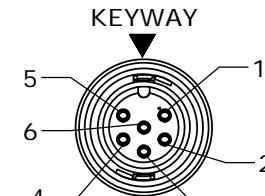

FACE VIEW
P/N: CARA62806SXXX84

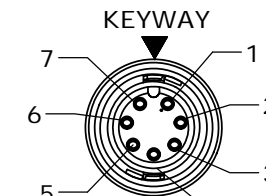

FACE VIEW
P/N: CARA62807SXXX84

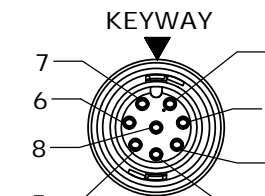

FACE VIEW
P/N: CARA62808SXXX84

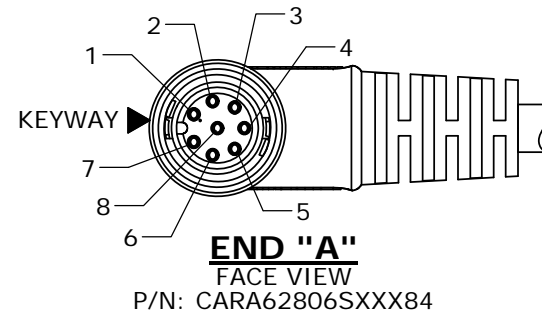
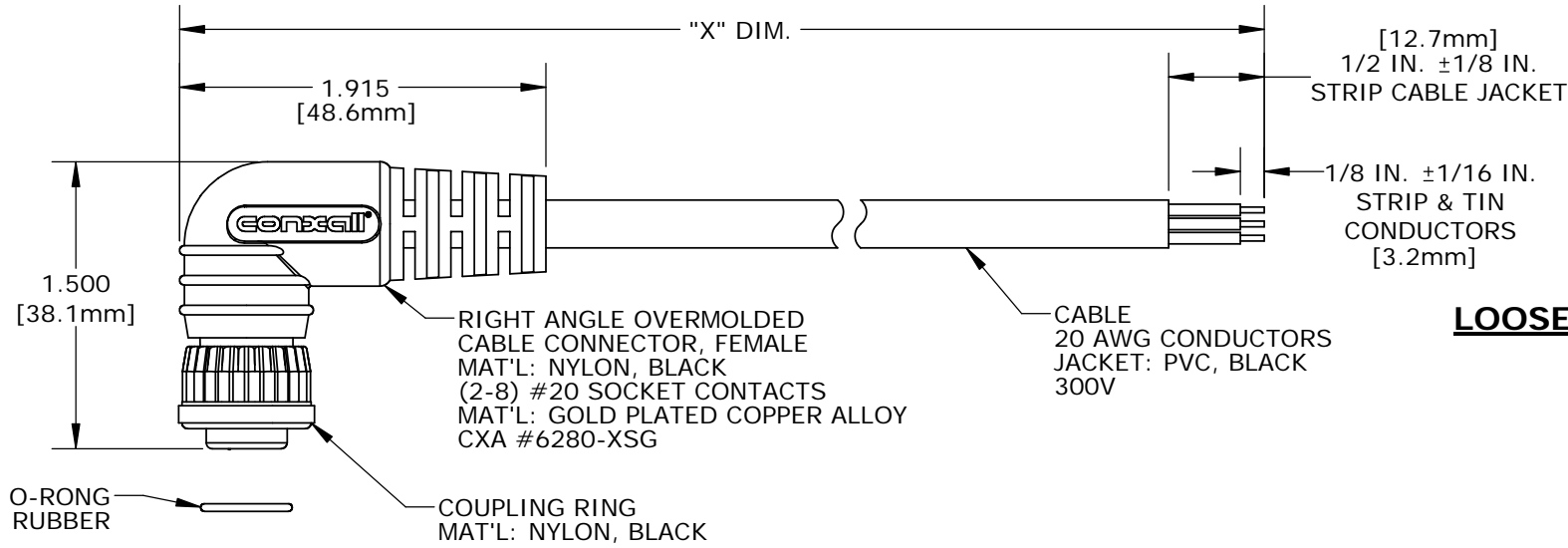

ASSY P/N	CABLE	COLOR CODE ENDS "A"
CARA62802SXXX84	2/20 AWG O.D. 0.215 REF	COLOR CODE
		POS. 1 POS. 2
CARA62803SXXX84	3/20 AWG O.D. 0.220 REF	WIRE COLOR CODE
		POS. 1 POS. 2 POS. 3
CARA62804SXXX84	4/20 AWG O.D. 0.235 REF	WIRE COLOR CODE
		POS. 1 POS. 2 POS. 3 POS. 4
CARA62805SXXX84	5/20 AWG O.D. 0.255 REF	WIRE COLOR CODE
		POS. 1 POS. 2 POS. 3 POS. 4 POS. 5
CARA62806SXXX84	6/20 AWG O.D. 0.275 REF	WIRE COLOR CODE
		POS. 1 POS. 2 POS. 3 POS. 4 POS. 5 POS. 6
CARA62807SXXX84	8/20 AWG O.D. 0.300 REF	WIRE COLOR CODE
		POS. 1 POS. 2 POS. 3 POS. 4 POS. 5 POS. 6 POS. 7
CARA62808SXXX84	8/20 AWG O.D. 0.300 REF	WIRE COLOR CODE
		POS. 1 POS. 2 POS. 3 POS. 4 POS. 5 POS. 6 POS. 7 POS. 8

DIMENSIONS IN BRACKET [] ARE METRIC.

CUSTOMER APPROVAL

THIS DOCUMENT CONTAINS CONFIDENTIAL INFORMATION PROPRIETARY TO CONXALL CORPORATION. ANY REPRODUCTION, DISCLOSURE, OR USE OF THIS DOCUMENT / INFORMATION IS EXPRESSLY PROHIBITED UNLESS AUTHORIZED IN WRITING BY CONXALL CORPORATION.

APPROVED BY: _____

DATE: _____

RoHS COMPLIANT

REV.	INIT.	DATE	DESCRIPTION
A	AN	02-26-18	DRAWING CREATED PER DOR 17-8167JS
<small>ALL INFORMATION ILLUSTRATED IS THE PROPERTY OF "CONXALL CORPORATION". UNAUTHORIZED DUPLICATION OR DISTRIBUTION OF THIS DOCUMENT IS PROHIBITED.</small>			<small>ORIG. DRAWN BY: AN</small> <small>DATE: 02-26-18</small>
<small>ALL UNITS ARE IN FEET, INCHES, FRACTION OF INCHES AND DECIMALS.</small>			
<small>601 E. WILDWOOD VILLA PARK, IL 60181</small>			TITLE: CABLE ASSEMBLY (2-8) #20 CONTACTS, FEMALE MINI-CON-X, RIGHT ANGLE STANDARD PRODUCT
<small>FILE: CARA6280XSXXX84</small> <small>DIRECTORY: SLW</small>			CUSTOMER: CARA6280XSXXX84 <small>PART NUMBER: CARA6280XSXXX84</small>
<small>SCALE: NTS</small> <small>SIZE: B</small> <small>SHEET: 1 OF 1</small>			<small>REV: A</small>