

FILE NO.	FOT109, FOT110
PART NO.	-

REVISIONS			
REV.	DESCRIPTION	DATE	ECO No.
A	RELEASE TO PRODUCT	2010/11/05	
			CHANG

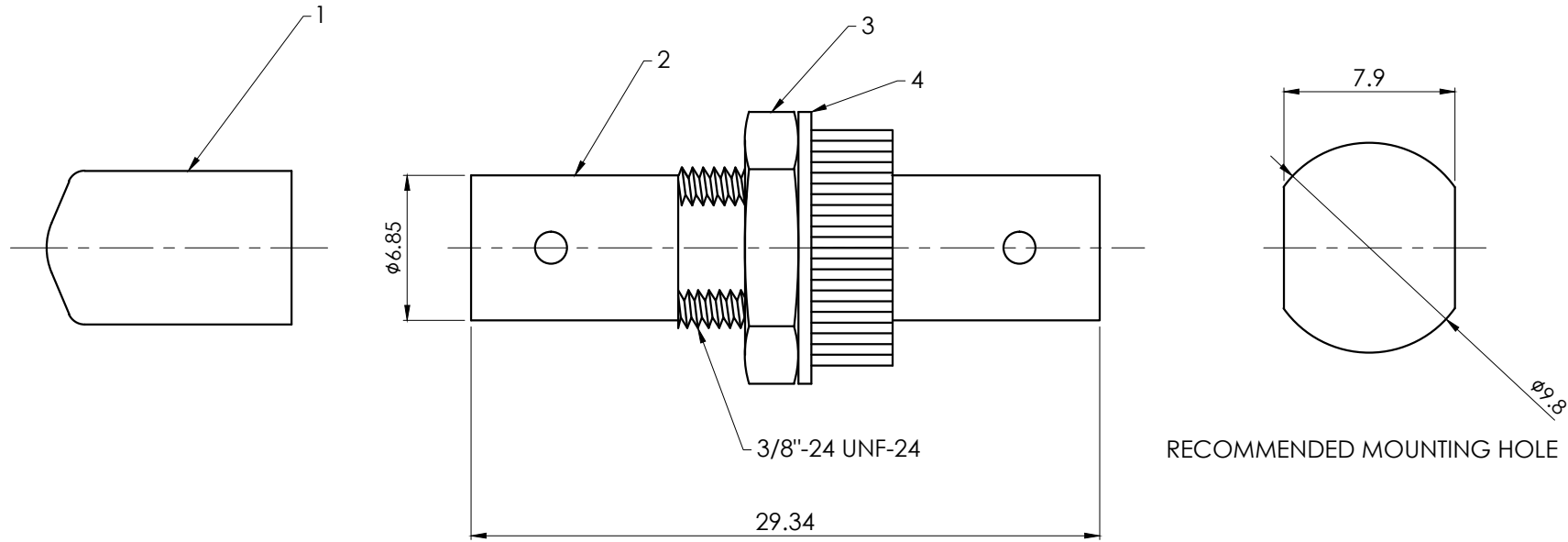

NOTES:

- 1.INSERTION LOSS 0.20dB/0.30dB (TYP./MAX.)
- 2.RETENTION FORCE:200GF(1.96N)~600GF(5.88N)
- 3.DURABILITY (500 MATINGS) 0.15dB MAX. INCREASE.
- 4.OPERATING TEMPERATURE : -40°C~+80°C.
- 5.ALL MATERIAL COMPLIANI WITH RoHS.
- 6.BLACK BOX P/N :

M.M. PhBr : FOT109
S.M. ZrO2 : FOT110

NO.	PART NAME	Q'TY	MATERIAL	PROCESSING
4	WASHER	1	C3604B	Ni Plating
3	NUT	1	C3604B	Ni Plating
2	ADAPTOR HOUSING	1	Zinc #5	Ni Plating
1	DUST CAP	1	PVC	---

MATERIAL		SIGNATURE	DATE	Another quality product from BLACK BOX NETWORK SERVICES 724-746-5500 • www.blackbox.com	
QUANTITY		DRAWN	LU		2010/11/05
		PROJECT ENGINEER	LU	2010/11/05	DWG. NAME ST ADAPTOR (S.M.&M.M.)
		CHECKED	LIU	2010/11/05	
		APPROVED	CHANG	2010/11/05	SIZE C DWG. NO. FOT109,FOT110
		DRAWING MANAGER	CHANG	2010/11/05	
SCALE : N:A				2010/11/05	REV. A