

コイン形二酸化マンガンリチウム電池  
Coin manganese dioxide lithium batteries

# CR2477X

■外形寸法 Dimensions(mm)

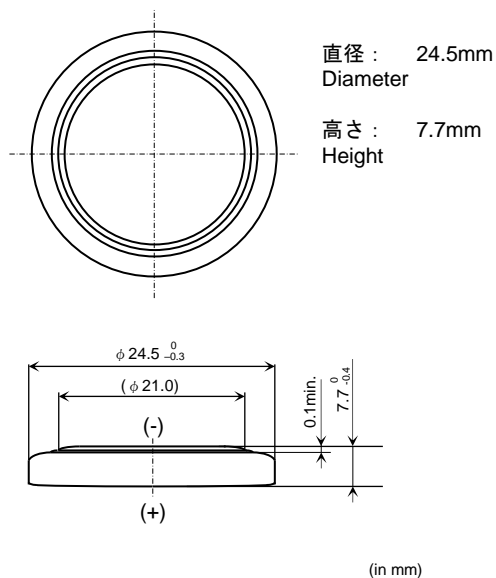

■定格 Specifications

公称電圧 <b>Nominal Voltage</b>	3 V
公称容量 (終止電圧 2.0V) <b>Nominal Capacity (2.0V cutoff)</b>	1000 mAh
推奨連続放電電流値 (容量利用率高) <b>Recommended Continuous Discharge Current (High capacity usage rate)</b>	≤ 1 mA
最大パルス放電電流(mA) *DOD50%時, 23°C, パルス長さ3sec, 2V以上 <b>Maximum Pulse Discharge current (mA)</b> *Assumption : Current to keep higher than 2V at 50% discharge with 23°C and pulse length 3sec.	30mA
標準質量 <b>Weight</b>	9.5 g
使用温度範囲 <b>Operating Temperature</b>	-40 ~ +85°C

用途 Applications

- 車載
  - ・タイヤ空気圧監視システム(TPMS)
  - ・スマートキー/キーレスエントリー
  - ・ETC (Electronic Toll Collection System) リーダ
  - ・ドライブカウンタ
- IoT / その他
  - ・スマートメータ
  - ・FA制御機器
  - ・トラッキングデバイス/センサーノード
- Automotive
  - ・TPMS(Tire Pressure Monitoring System)
  - ・Smart Key/Keyless entry
  - ・Toll Collection Device
  - ・Drive counter
- IoT / Other
  - ・Smart meters
  - ・Factory Automation Instruments
  - ・Tracking devices/Sensor node

■放電温度特性

Discharge Temperature Characteristics

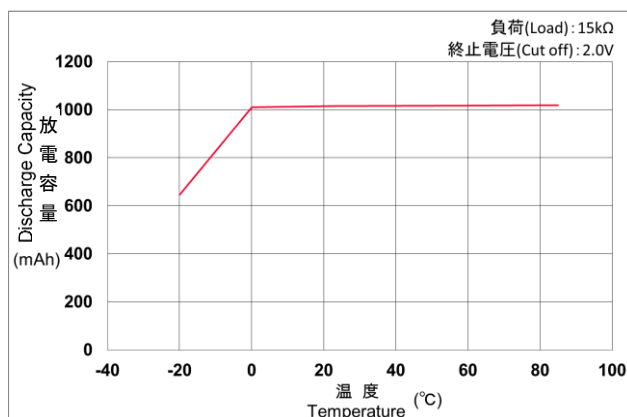

■保存特性

Storage Characteristic

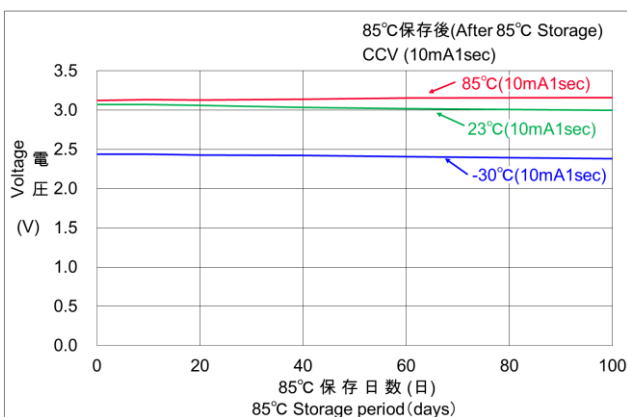

■ 放電負荷特性

Discharge Characteristics by Load

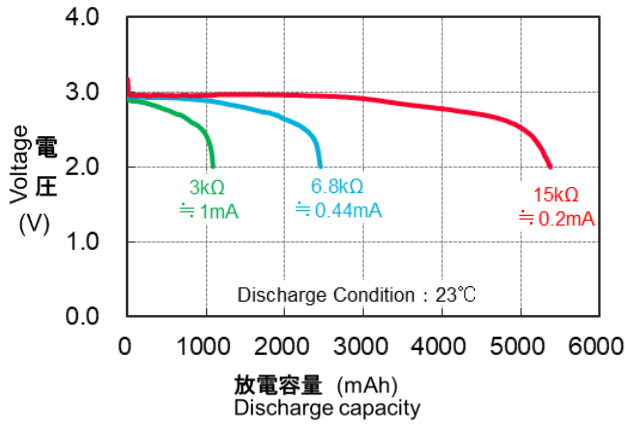

■ 放電温度特性

Discharge Characteristics by Temperature

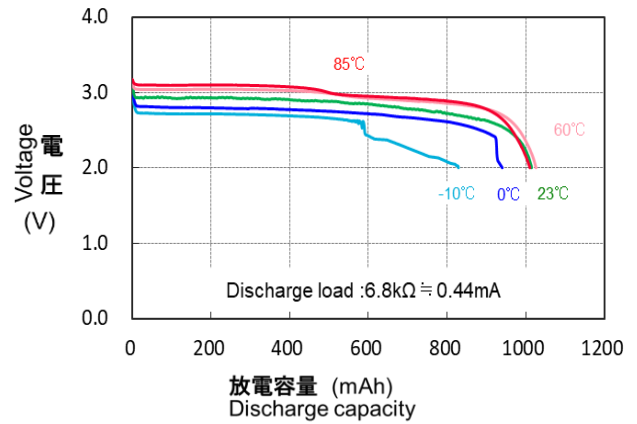

■ 閉路電圧特性

Close Circuit Voltage by Capacity

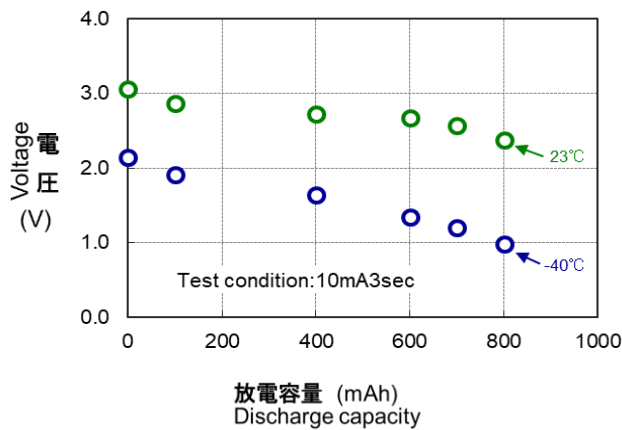

■ 内部抵抗

Impedance by depth of discharge

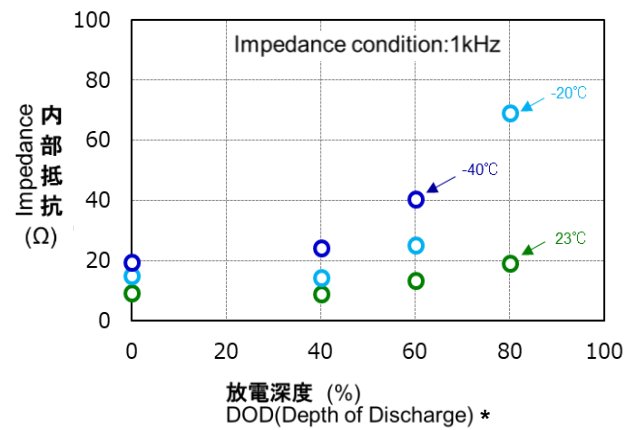

\*DOD 100% = End of Life

■ 自己放電特性

Self Discharge Characteristic by Temperature

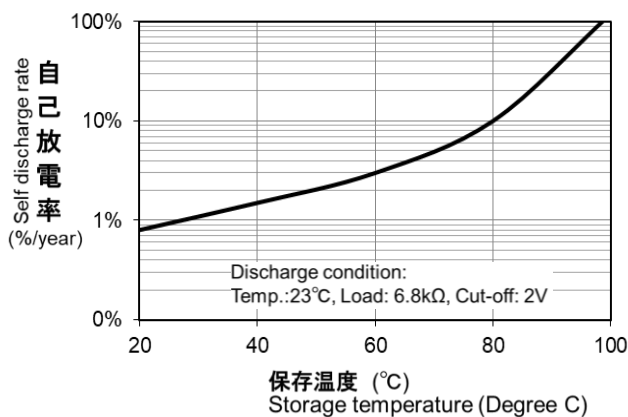

\*記載のデータ及び数値は、参考値であり保証値ではありません。

\*Data is not guaranteed, and is provided for reference purposes only.