

Dec.1.2019 Copyright 2019 HIROSE ELECTRIC CO., LTD. All Rights Reserved.  
 In case of consideration for using Automotive equipment / device which demand high reliability, kindly contact our sales window correspondents.

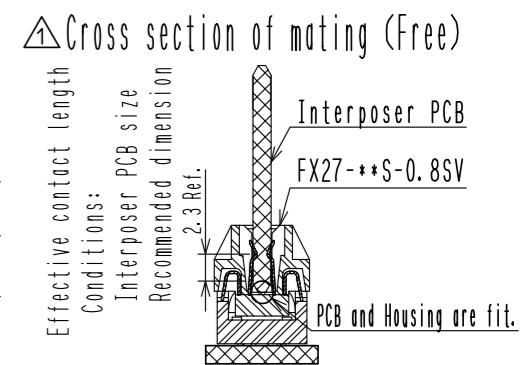
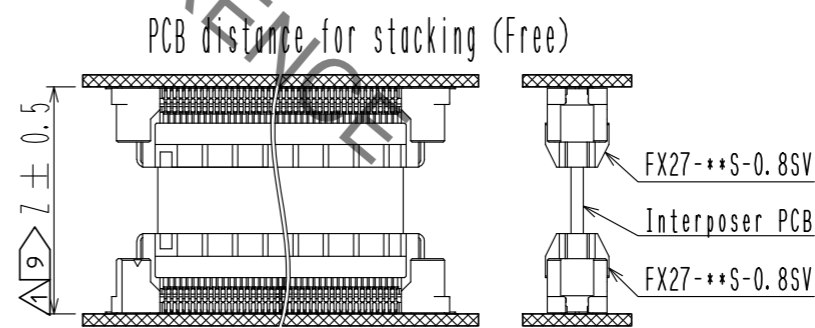
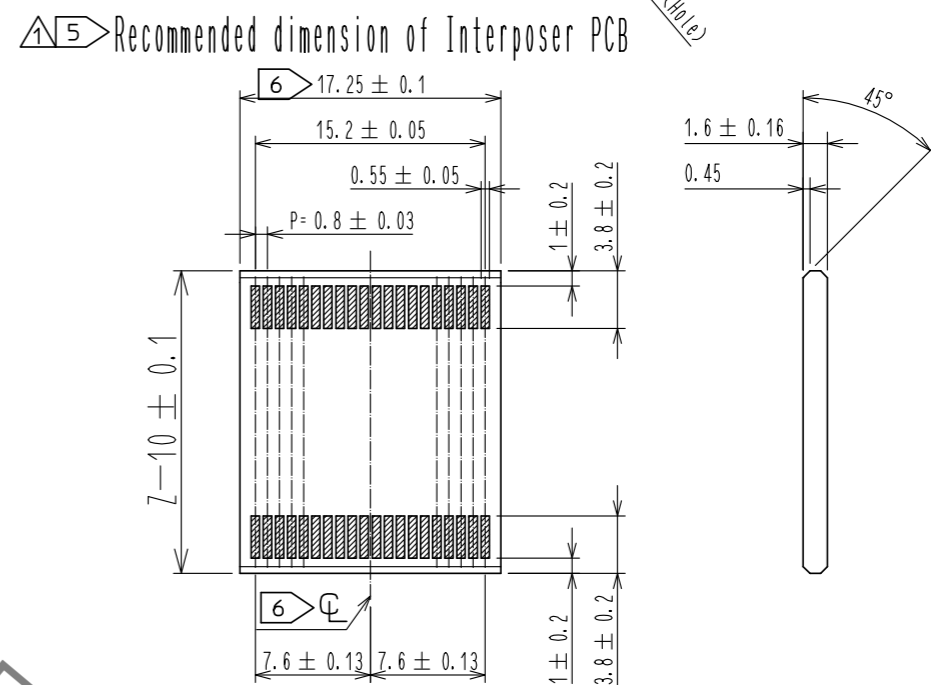
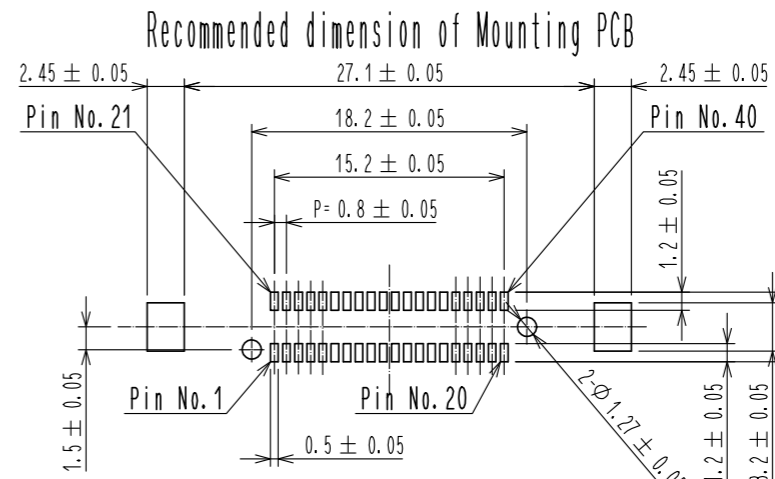
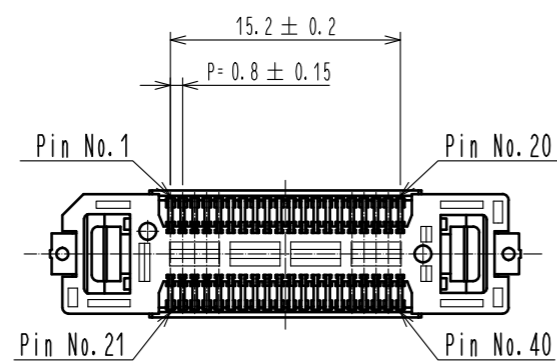
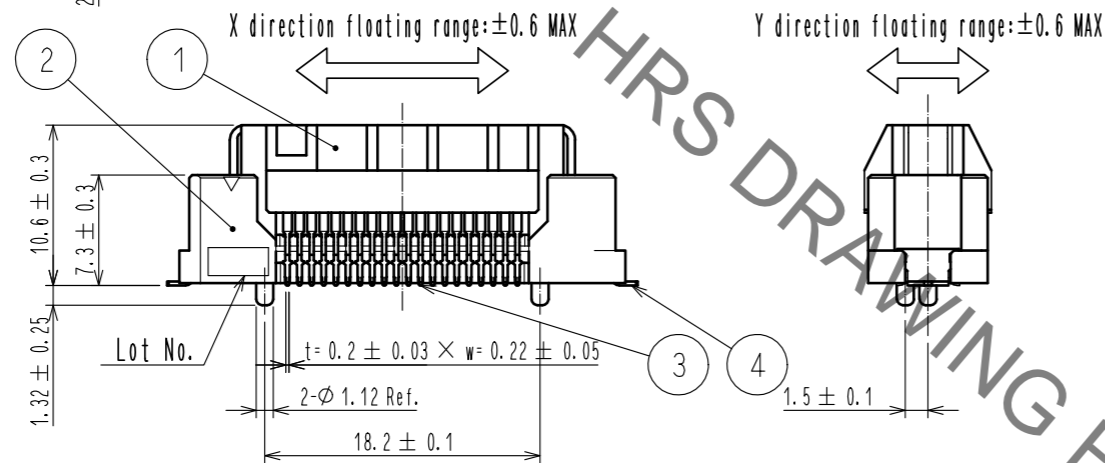
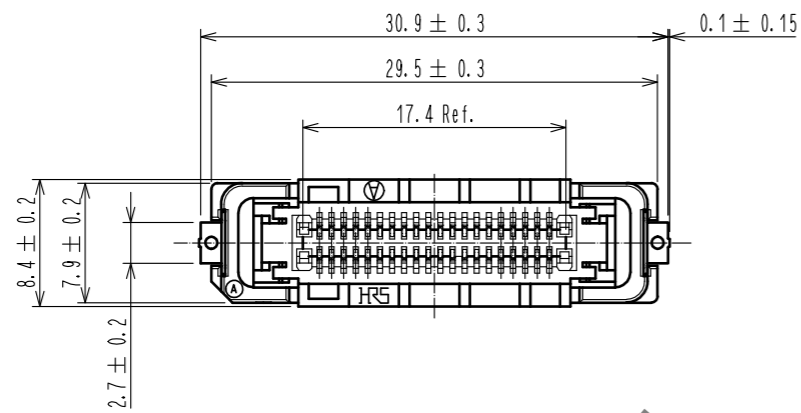

- Note
1. Lead CO-Planarity is 0.1mm MAX.
  2. Packing type : Tape and reel. 300pcs per reel.
  3. It shows the vacuum pickup area.  
Remove the mylar tape before mating connectors.
  4. Blemish and hit mark can be occurred through out the manyufwakuchuaringu process which doesn't affect quality level.
  5. Recommended dimension of Interposer PCB.
  6.  $\phi$  mark indicates the center line of outer dimension of 17.25mm.
  7. Those dimensions indicate the cutout area for pre-fixing lock.
  8. Hatching area of INTERPOSER PCB shows the contact area with connector.  
The plating is Nickel 3 $\mu$ min + Gold 0.2 $\mu$ m to 0.4 $\mu$ m(Electroplating and hard plating).
9. Stacking Height : 22mm Min.

NO.	MATERIAL	FINISH . REMARKS	NO.	MATERIAL	FINISH . REMARKS
3	Copper alloy	Contact: Gold plating 0.2 $\mu$ m MIN Lead : Gold plating 0.03 $\mu$ m MIN Under :Nickel plating 1.3 $\mu$ m MIN	7	Polyimide	Tape for vacuum pickup
2	Polyamide	Black. UL94V-0	6	Polystyrene	Emboss cover tape
1	Polyamide	Black. UL94V-0	5	Polystyrene	Emboss carrier tape
			4	Brass	Tin reflow plating 1 $\mu$ m MIN

UNITS	SCALE	COUNT	DESCRIPTION OF REVISIONS	DESIGNED	CHECKED	DATE
mm	2:1	7	DIS-F-00005079	MT. ITANO	HT. YAMAGUCHI	20190826

APPROVED	DATE	DRAWING NO.
:NH. NAKATA	20171101	EDC-376551-00-00
CHECKED	DATE	PART NO.
:MK. NAGATA	20171031	FX27-40S-0.8SV
DESIGNED	DATE	CODE NO.
:KJ. NISHIWAKI	20171031	CL577-1002-0-00
DRAWN	DATE	
:KJ. NISHIWAKI	20171031	

Dec.1.2019 Copyright 2019 HIROSE ELECTRIC CO., LTD. All Rights Reserved.  
 In case of consideration for using Automotive equipment / device which demand high reliability, kindly contact our sales window correspondents.

2 Drawing for packing (Free)

The direction of pulling out

Reeled dimension (Free)

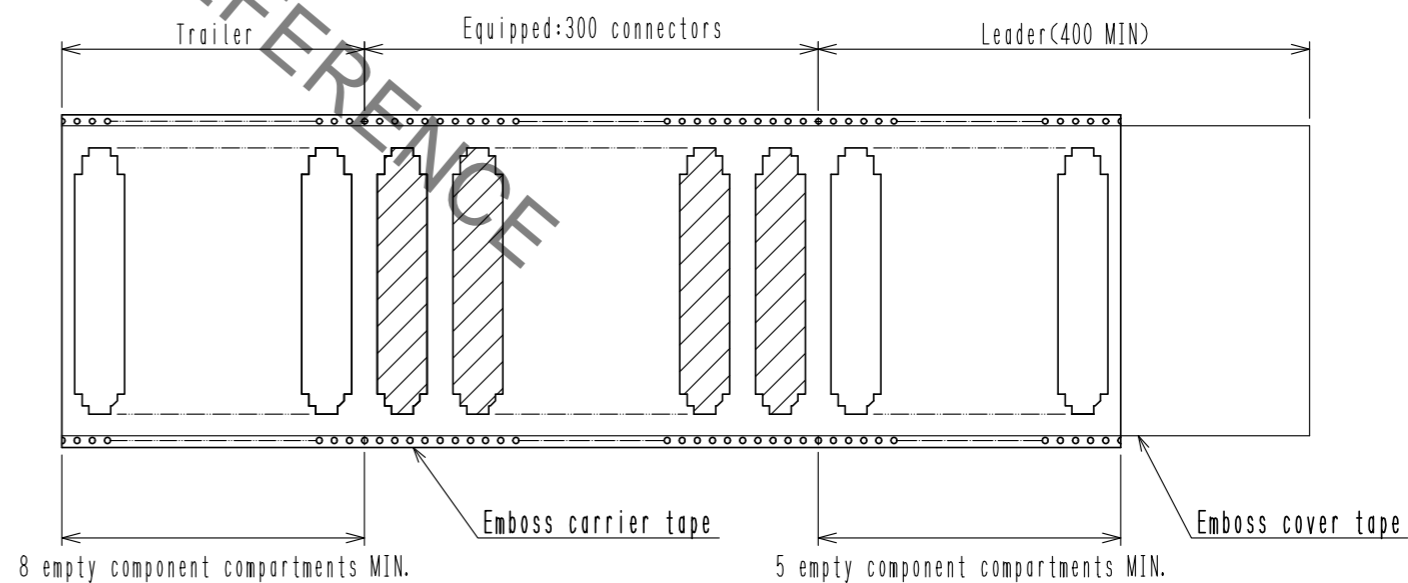
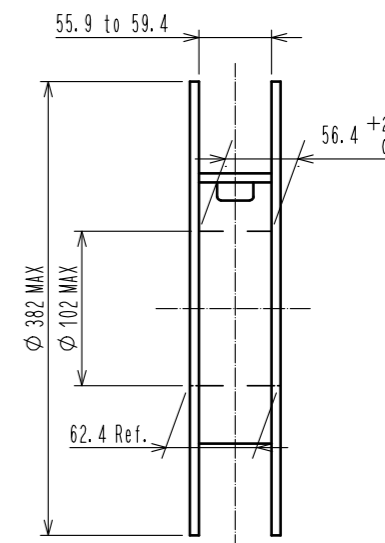
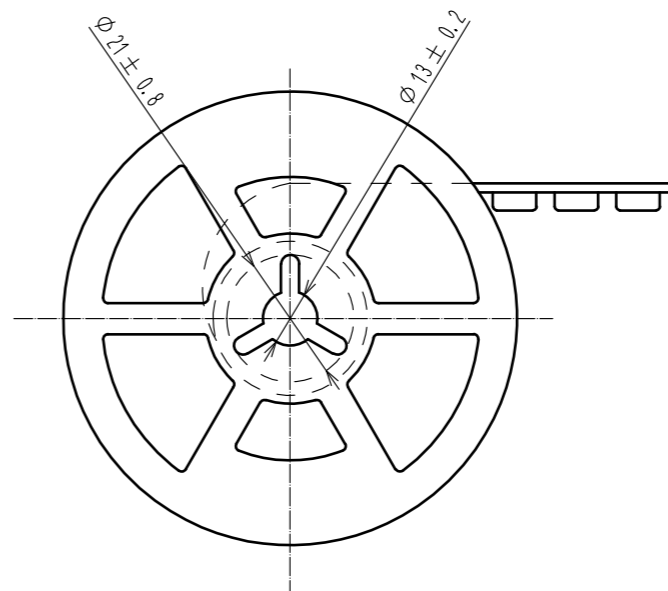
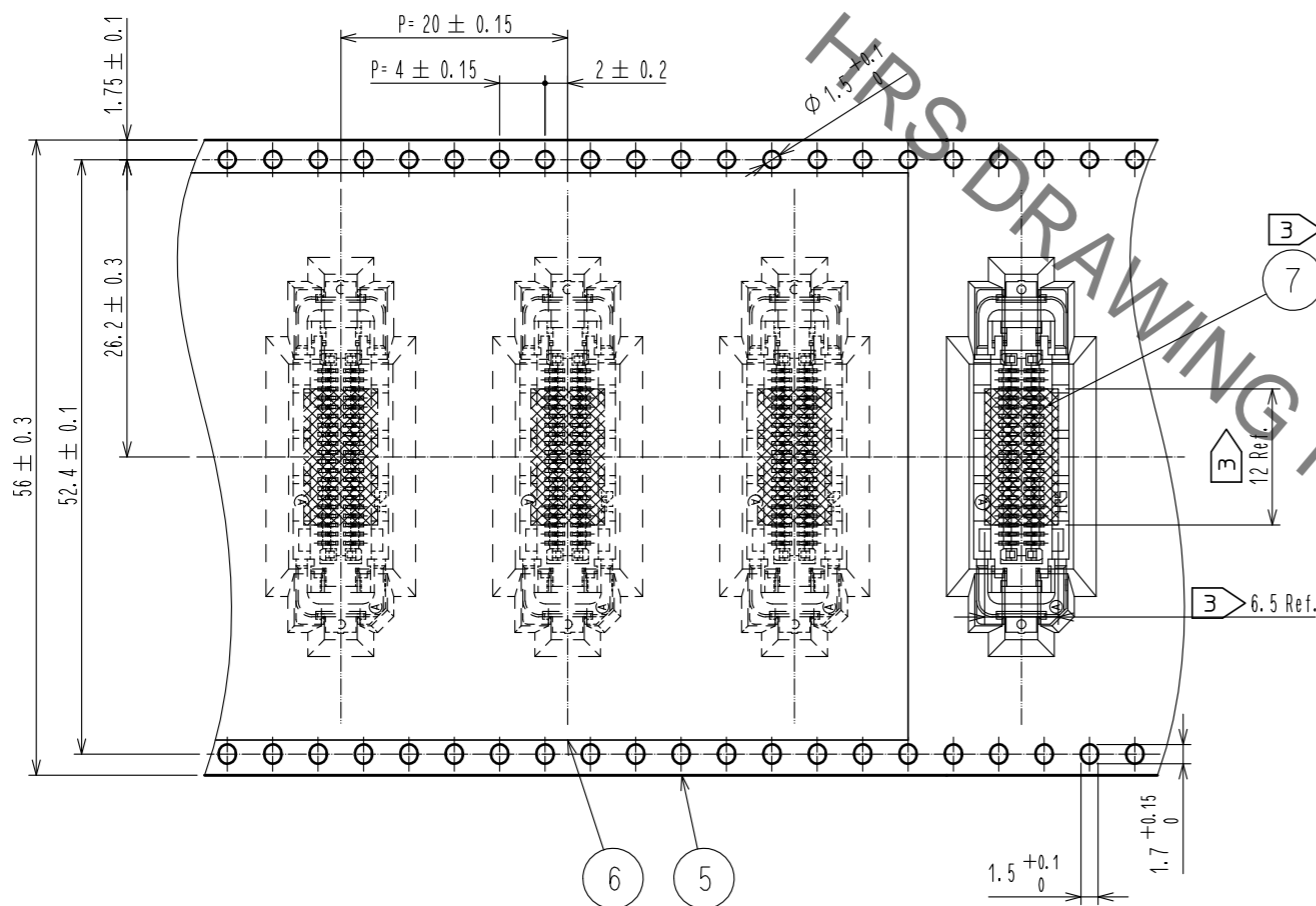

<b>HRS</b>	DRAWING NO.	EDC-376551-00-00	2/5
	PART NO.	FX27-40S-0.8SV	
	CODE NO.	CL577-1002-0-00	

Dec.1.2019 Copyright 2019 HIROSE ELECTRIC CO., LTD. All Rights Reserved.  
In case of consideration for using Automotive equipment / device which demand high reliability, kindly contact our sales window correspondents.

### Simple Lock for Initial Insertion and Removal (Free)

The notches provided in the mating PCB Interposer are used to lock the connection engaged with the locking latch of the connector.

40pos., 60pos. PCB Interposer      80pos., 100pos., 120pos. PCB Interposer

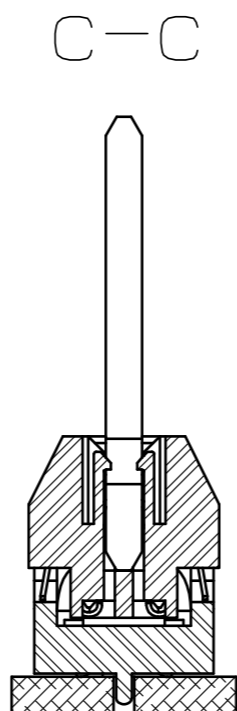
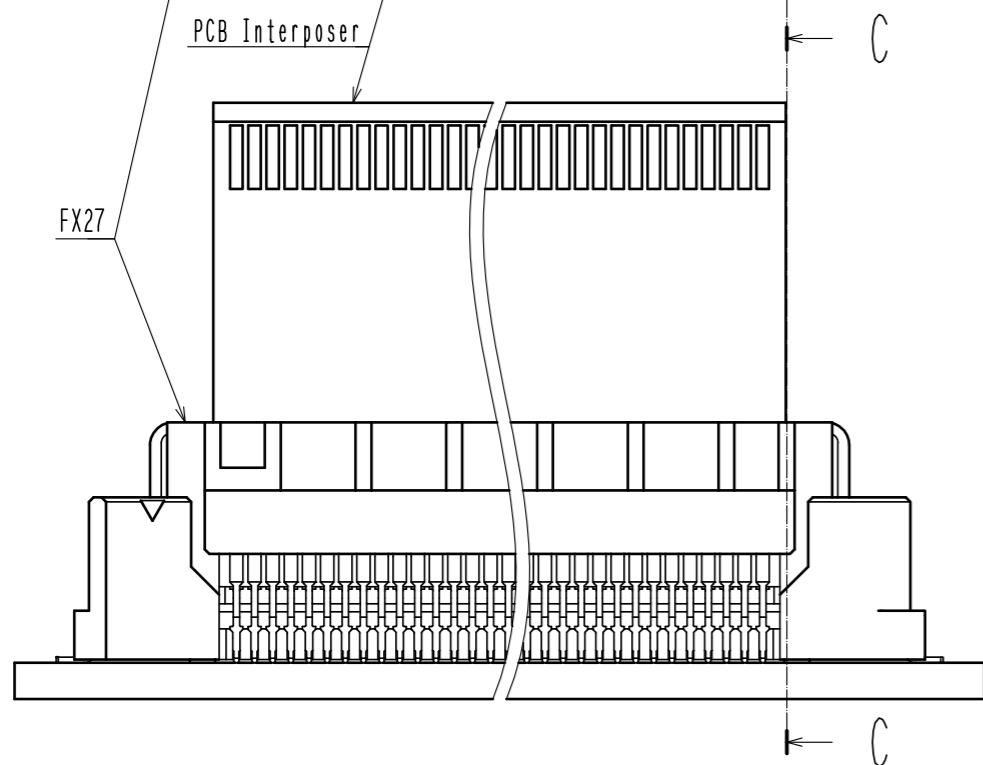
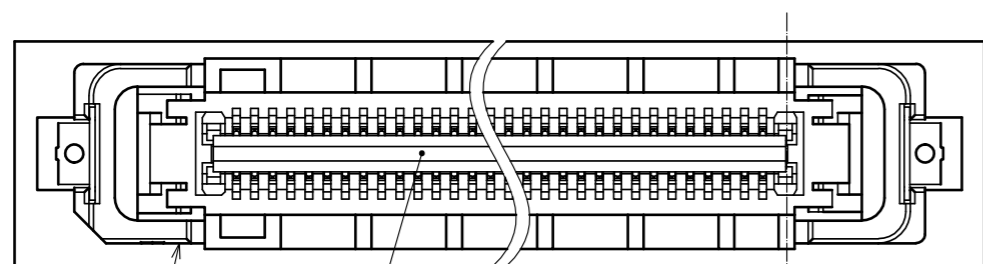
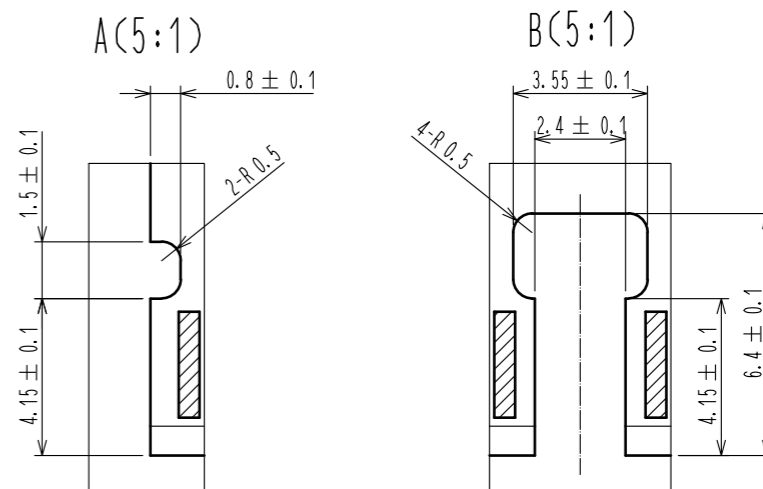
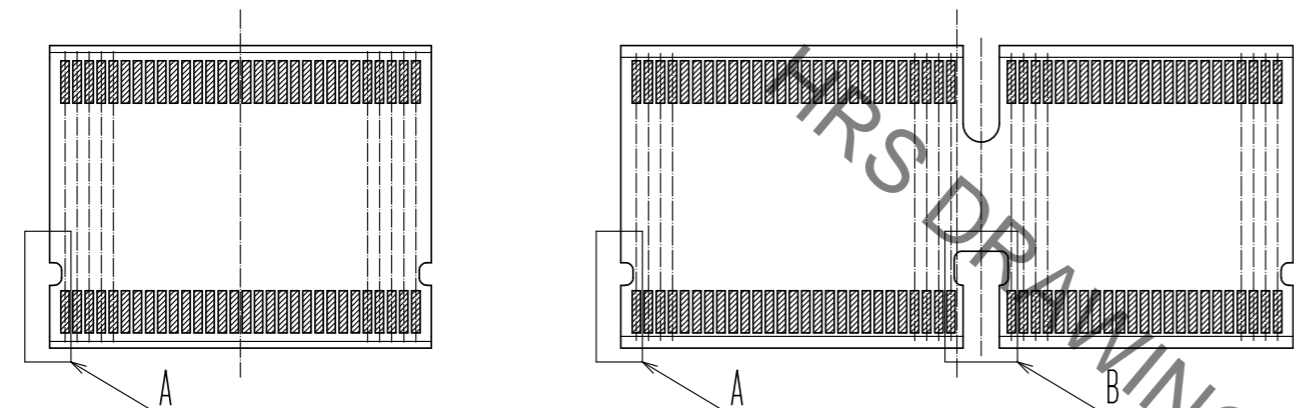

Structure drawing

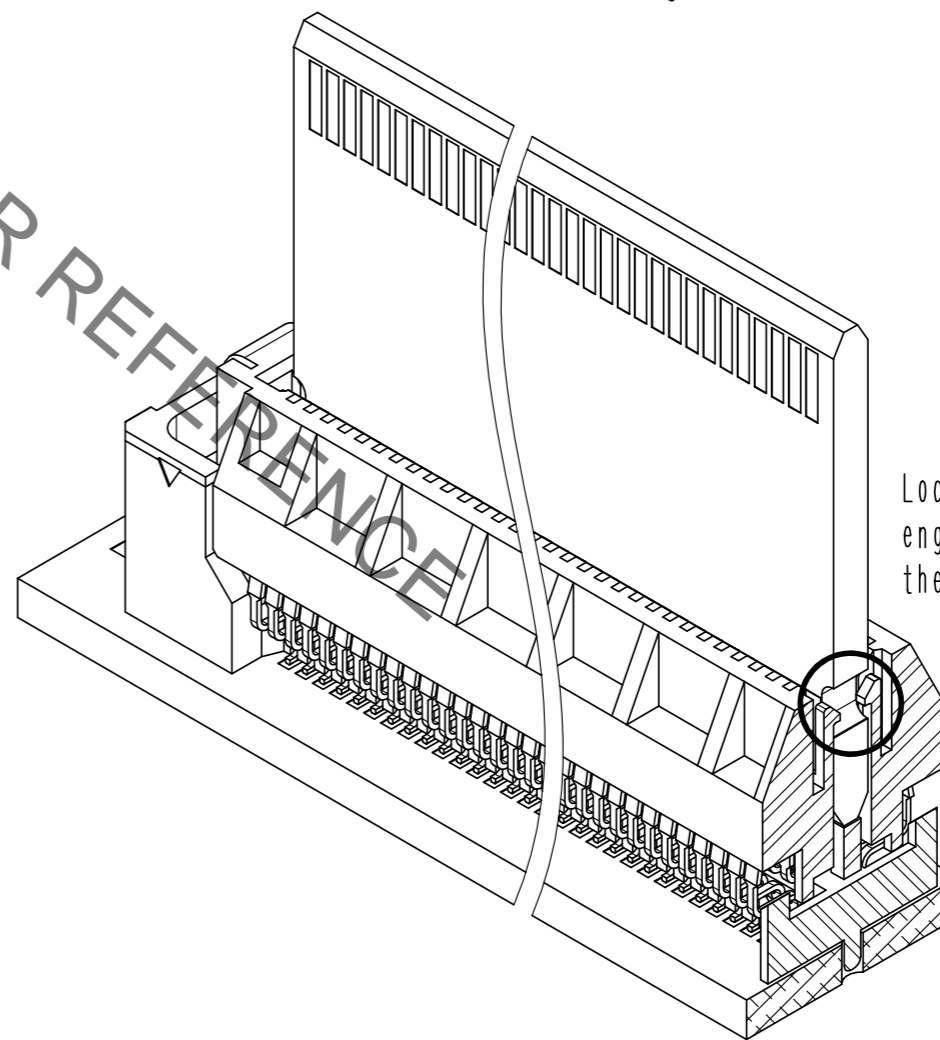

Locking latch of the connector is engaged with the notch of the PCB Interposer.

<b>HRS</b>	DRAWING NO.	EDC-376551-00-00	3/5
	PART NO.	FX27-40S-0.8SV	
	CODE NO.	CL577-1002-0-00	

# △Pin Assignment

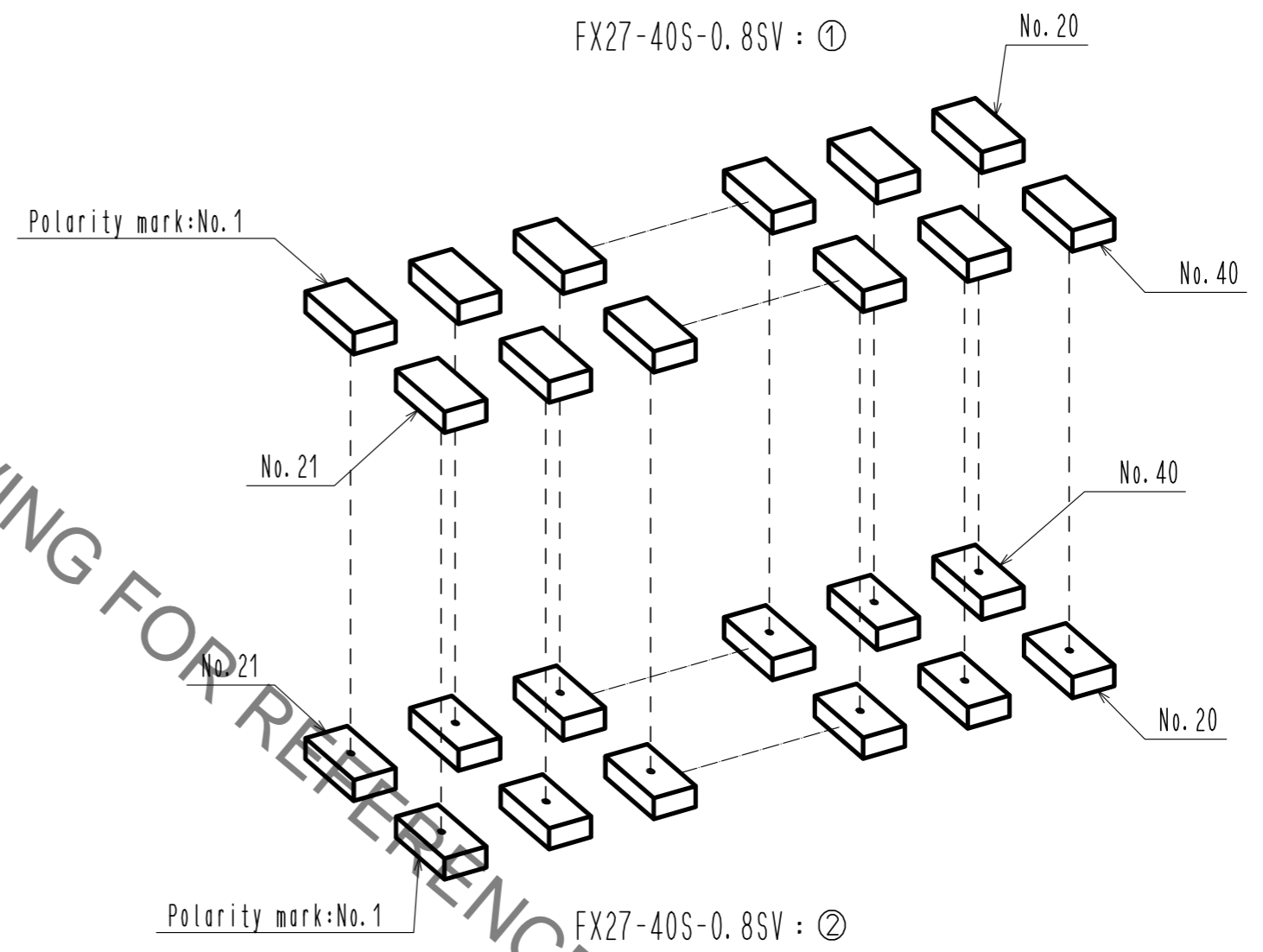
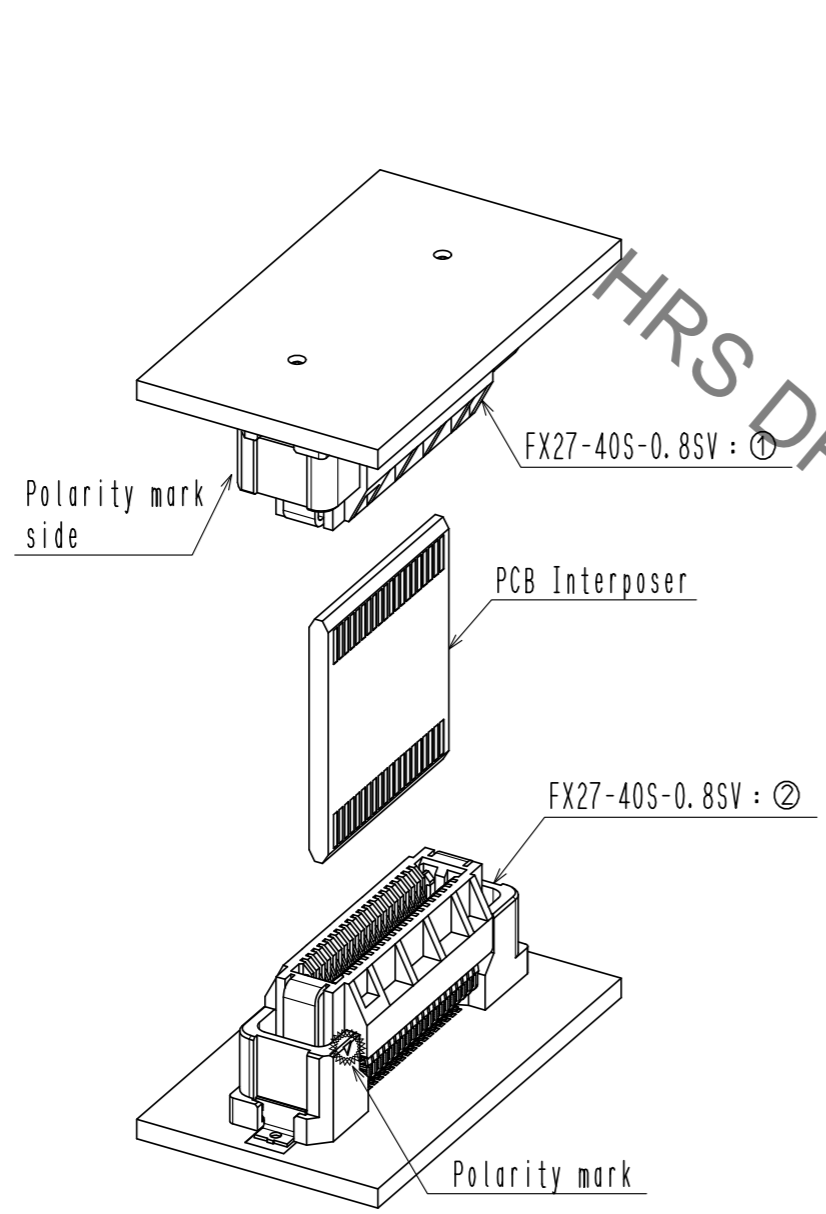

When the connector is used as shown in the sketch to the above, the polarity mark of FX27-40S-0.8SV of ① and ② are reversed. Attention should be paid to the pin assignment of the circuits on the board.

<b>HRS</b>	DRAWING NO.	EDC-376551-00-00
	PART NO.	FX27-40S-0.8SV
	CODE NO.	CL577-1002-0-00
		△ 4/5

Dec.1.2019 Copyright 2019 HIROSE ELECTRIC CO., LTD. All Rights Reserved. In case of consideration for using Automotive equipment / device which demand high reliability, kindly contact our sales window correspondents.

Dec.1.2019 Copyright 2019 HIROSE ELECTRIC CO., LTD. All Rights Reserved.  
In case of consideration for using Automotive equipment / device which demand high reliability, kindly contact our sales window correspondents.

### △ PCB supports

This connector can absorb misalignment of PCB but cannot absorb vibration itself.  
When PCB are supported by a connector only, the connector will be loaded excessively,  
which may result in a damage or contact failure.  
Take measures to secure PCB with an object other than connector as shown in the following figure.

If the spacer is installed away from the connector, the PCB may bend and the connector may not be securely mated.  
Fit the spacer after the connector securely mated.

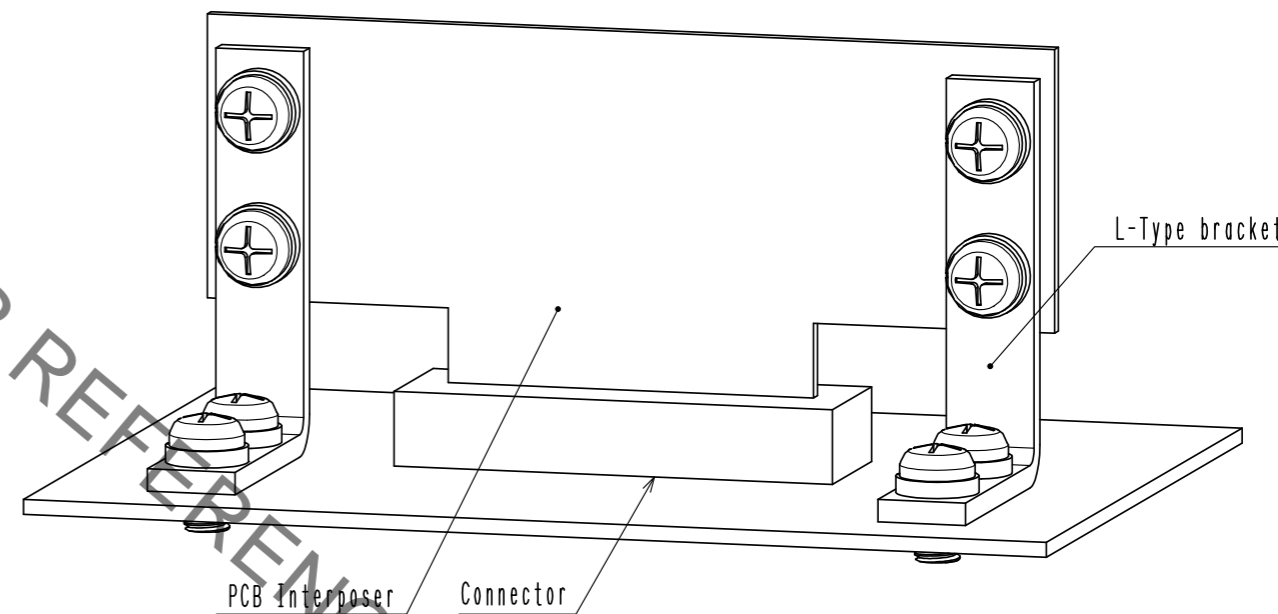
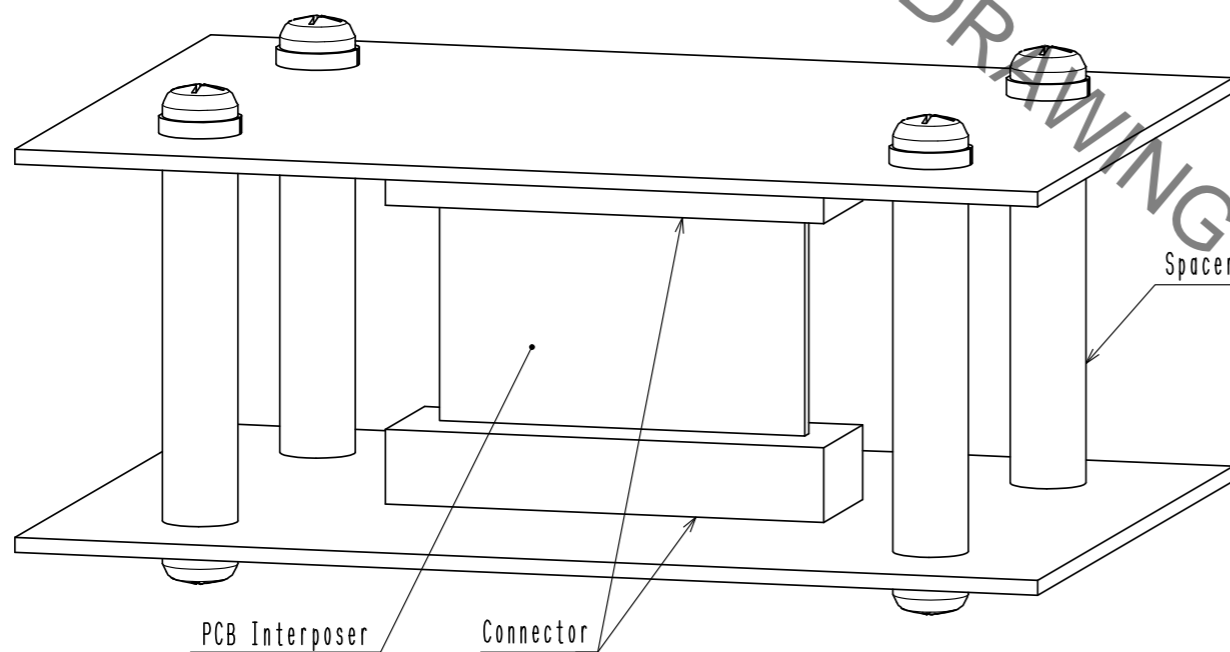

<b>HRS</b>	DRAWING NO.	EDC-376551-00-00
	PART NO.	FX27-40S-0.8SV
	CODE NO.	CL577-1002-0-00
		△ 5/5