

THIS DRAWING IS UNPUBLISHED. RELEASED FOR PUBLICATION 20
 © COPYRIGHT 20 BY - ALL RIGHTS RESERVED.

REVISIONS					
P	LTR	DESCRIPTION	DATE	DWN	APVD
2		REMOVE 2343405-2 AND 2343405-3	19FEB2019	JS	EH
A		REVISED PER ECR-19-010853	16JUL2019	SR	DD

NOTES:

- 1 MATERIALS AND FINISH:
 -MODULE HOUSING: PBT, COLOR: GREY
 -CONTACTS: BRASS, FINISH: Sn OVER Ni
 -O-RING: SILICON RUBBER, COLOR: BLACK
- 2. MUST COMPLY WITH DIRECTIVE 2002/95/EC (ROHS)
- 3 LOCATION OF FLAT ON RECEPTACLE (TE P/N 2213858-1)
 THREAD SECTION IN FULL MATED POSITION
- 4. COMPATIBLE DOME IS 2329013-X.
- 5. MATES TO RECEPTACLE ASSEMBLIES 2343403-1 OR 1-2343403-1.

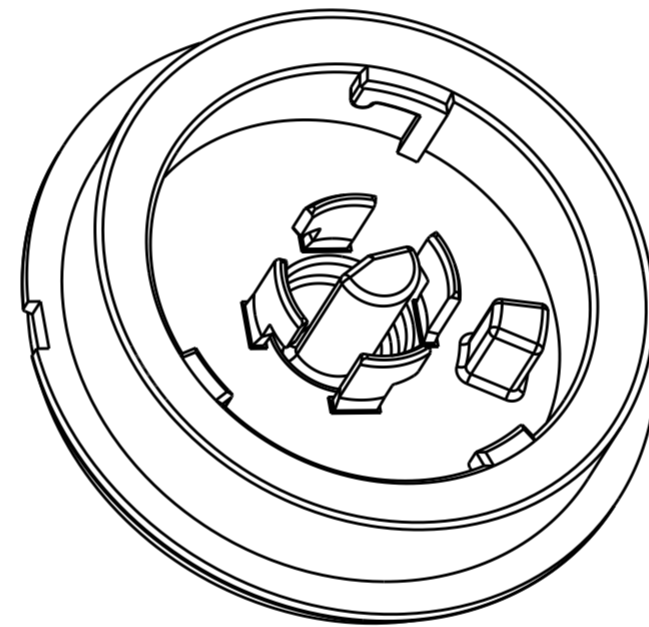
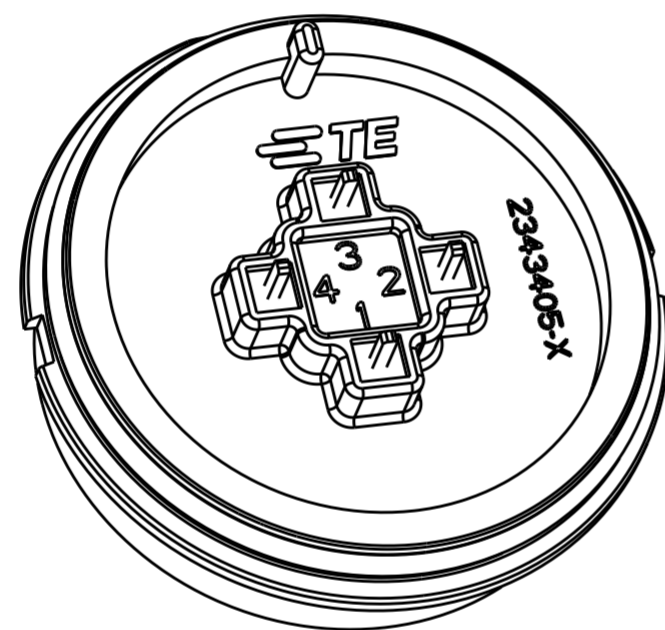

MODULE BASE ASSY, KEY A	POSITION A	2343405-1
DESCRIPTION	KEYING	PART NO.

THIS DRAWING IS A CONTROLLED DOCUMENT.		DWN C. DAILY 03OCT2018	STE TE Connectivity	
		CHK M. MOSTOLLER 03OCT2018		
DIMENSIONS: mm	TOLERANCES UNLESS OTHERWISE SPECIFIED:	APVD -	NAME MODULE BASE ASSEMBLY, LUMAWISE ENDURANCE S 40mm DIAMETER, KEYED	
	0 PLC ± 1 PLC ±0.2 2 PLC ±0.15 3 PLC ±0 4 PLC ±0 ANGLES ±1° FINISH -	PRODUCT SPEC 108-133073	SIZE A2	CAGE CODE -
MATERIAL SEE NOTES		APPLICATION SPEC 114-133074	DRAWING NO. G-2343405	RESTRICTED TO -
		WEIGHT -	SCALE 1:1 SHEET 1 OF 3 REV A	
		CUSTOMER DRAWING		

THIS DRAWING IS UNPUBLISHED. RELEASED FOR PUBLICATION 20
 © COPYRIGHT 20 BY - ALL RIGHTS RESERVED.

REVISIONS				
P	LTR	DESCRIPTION	DATE	APVD
-	-	SEE SHEET 1	-	-

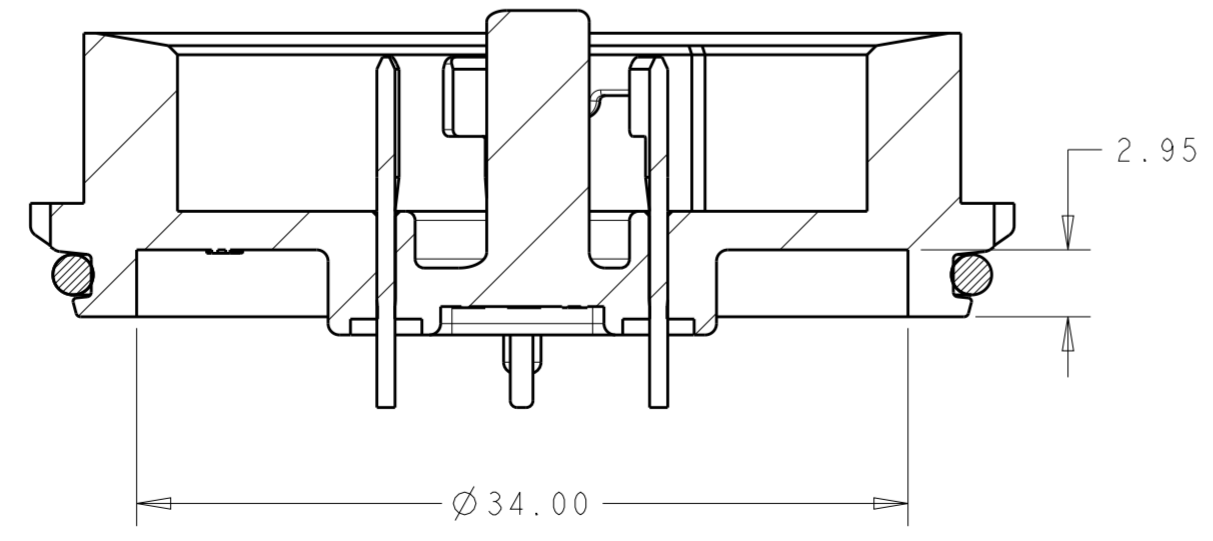
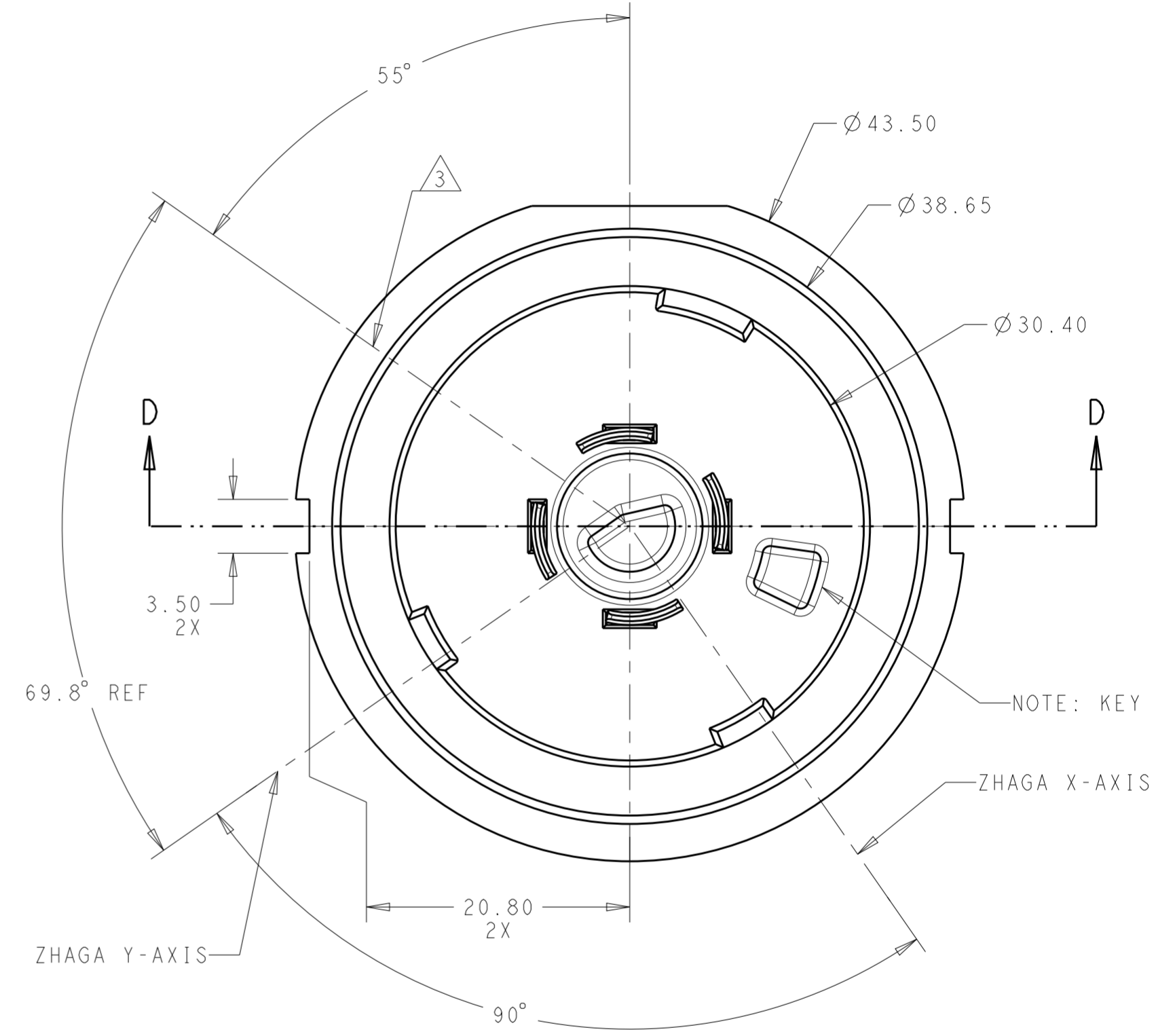
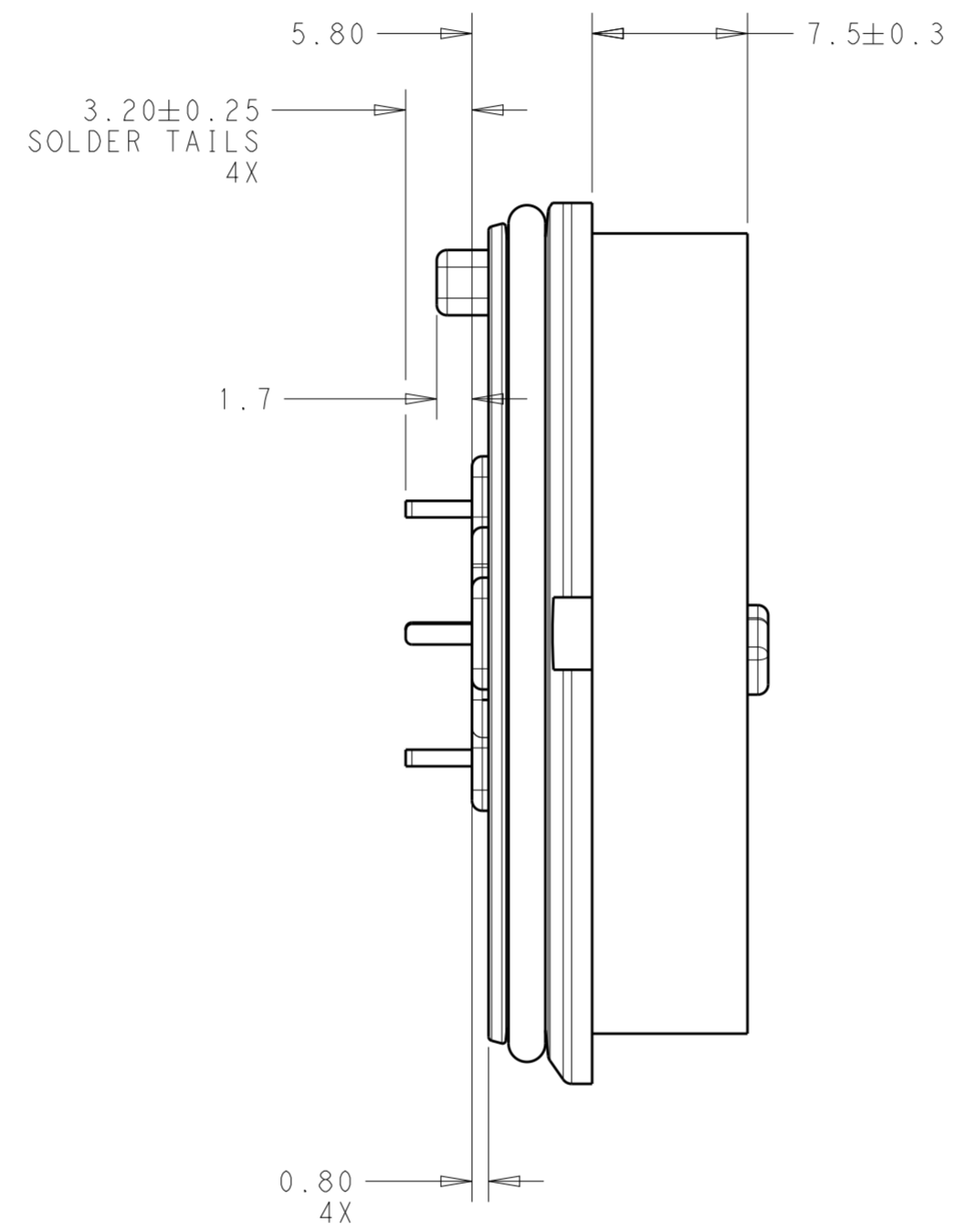
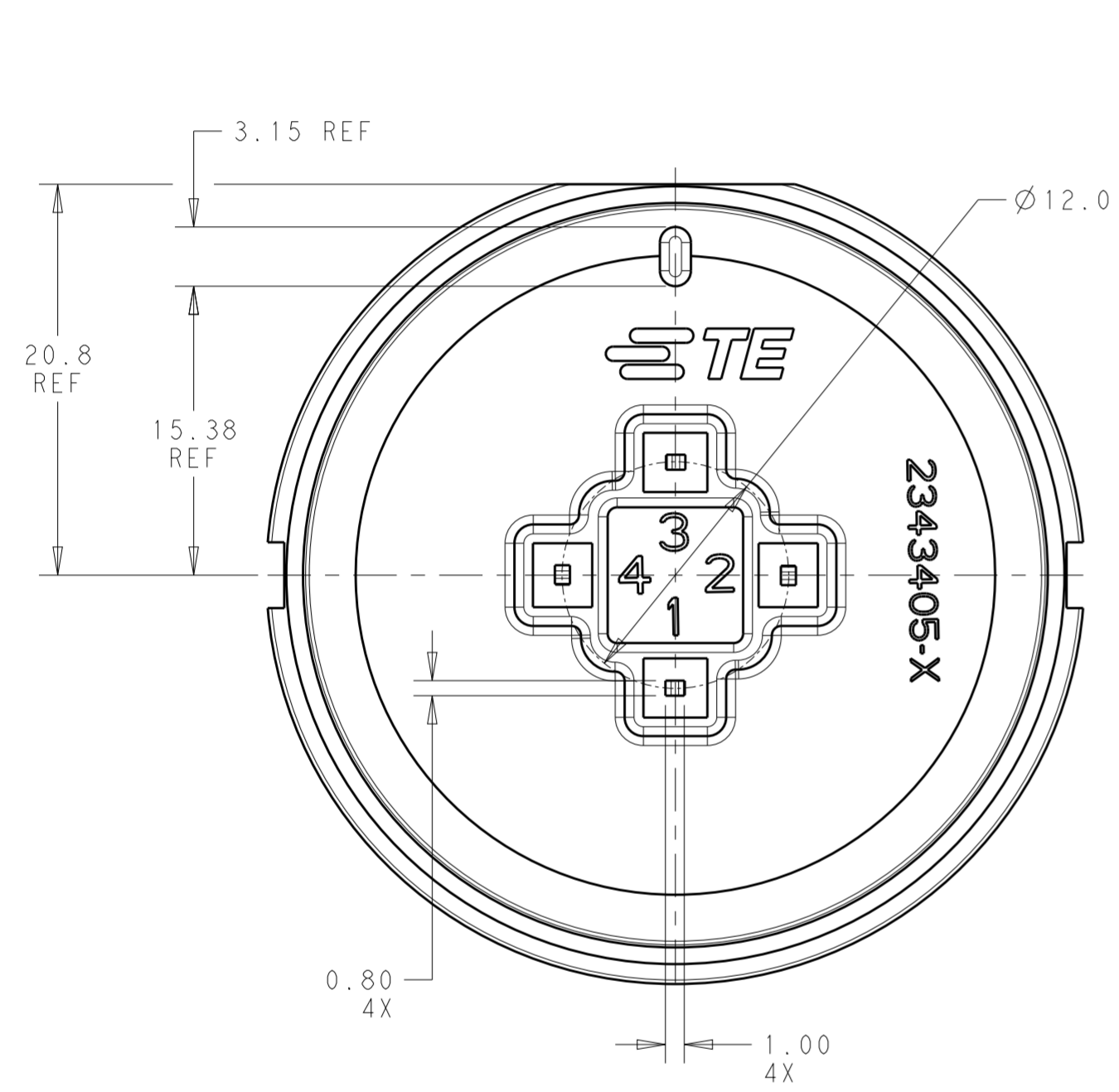

THIS DRAWING IS A CONTROLLED DOCUMENT.		DWN C. DAILY 03OCT2018	STE TE Connectivity	
		CHK M. MOSTOLLER 03OCT2018		
DIMENSIONS: mm		APVD -	NAME MODULE BASE ASSEMBLY, LUMAWISE ENDURANCE S 40mm DIAMETER, KEYED	
TOLERANCES UNLESS OTHERWISE SPECIFIED:		PRODUCT SPEC 108-133073	SIZE A2	
0 PLC ±		APPLICATION SPEC 114-133074	CAGE CODE -	
1 PLC ±0.2		WEIGHT -	DRAWING NO. C-2343405	
2 PLC ±0.15		CUSTOMER DRAWING	RESTRICTED TO -	
3 PLC ±0		SCALE 1:1	SHEET 2 OF 3	
4 PLC ±0			REV A	
ANGLES ±1°				
FINISH -				
MATERIAL SEE NOTES				

THIS DRAWING IS UNPUBLISHED. RELEASED FOR PUBLICATION 20
 © COPYRIGHT 20 BY - ALL RIGHTS RESERVED.

REVISIONS				
P	LTR	DESCRIPTION	DATE	APVD
-	-	SEE SHEET 1	-	-

LATCH DETAIL
SECTION B-B
SCALE 3:1

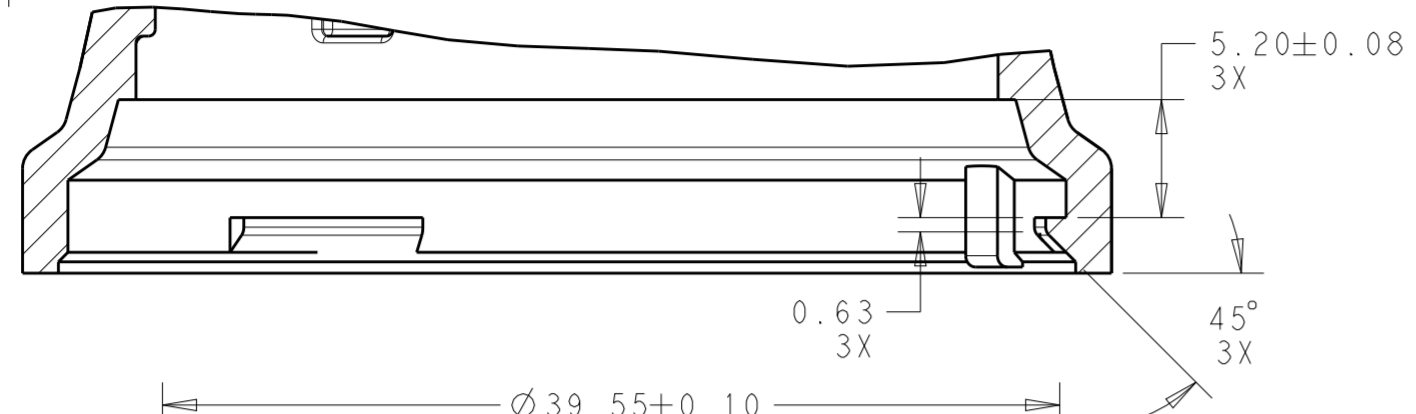

KEY DETAIL
SECTION A-A
SCALE 3:1

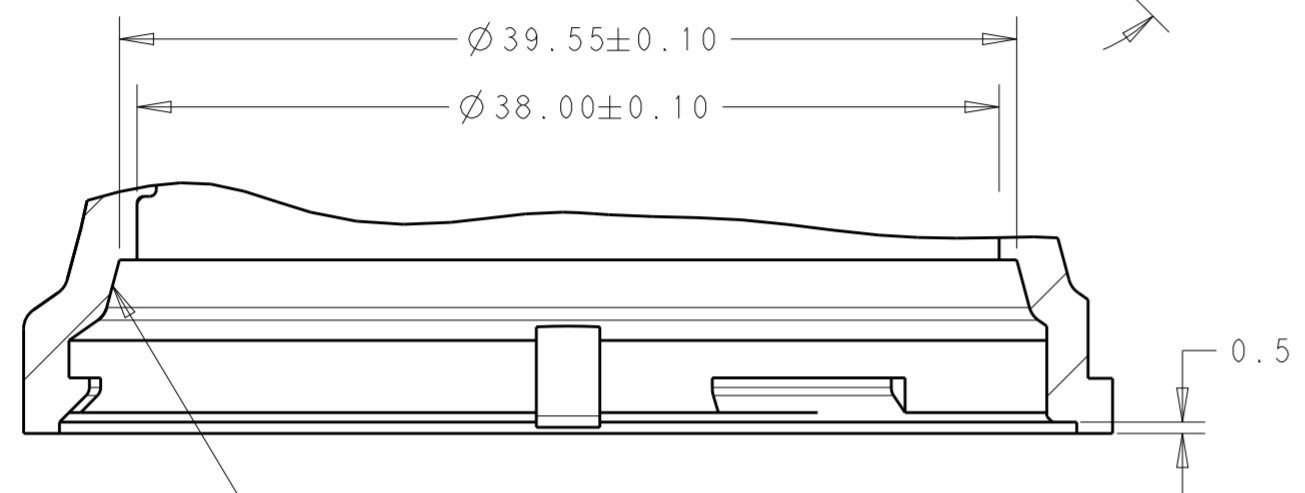

O-RING SEALING SURFACE
MUST BE SMOOTH AND
FREE OF DEFECTS

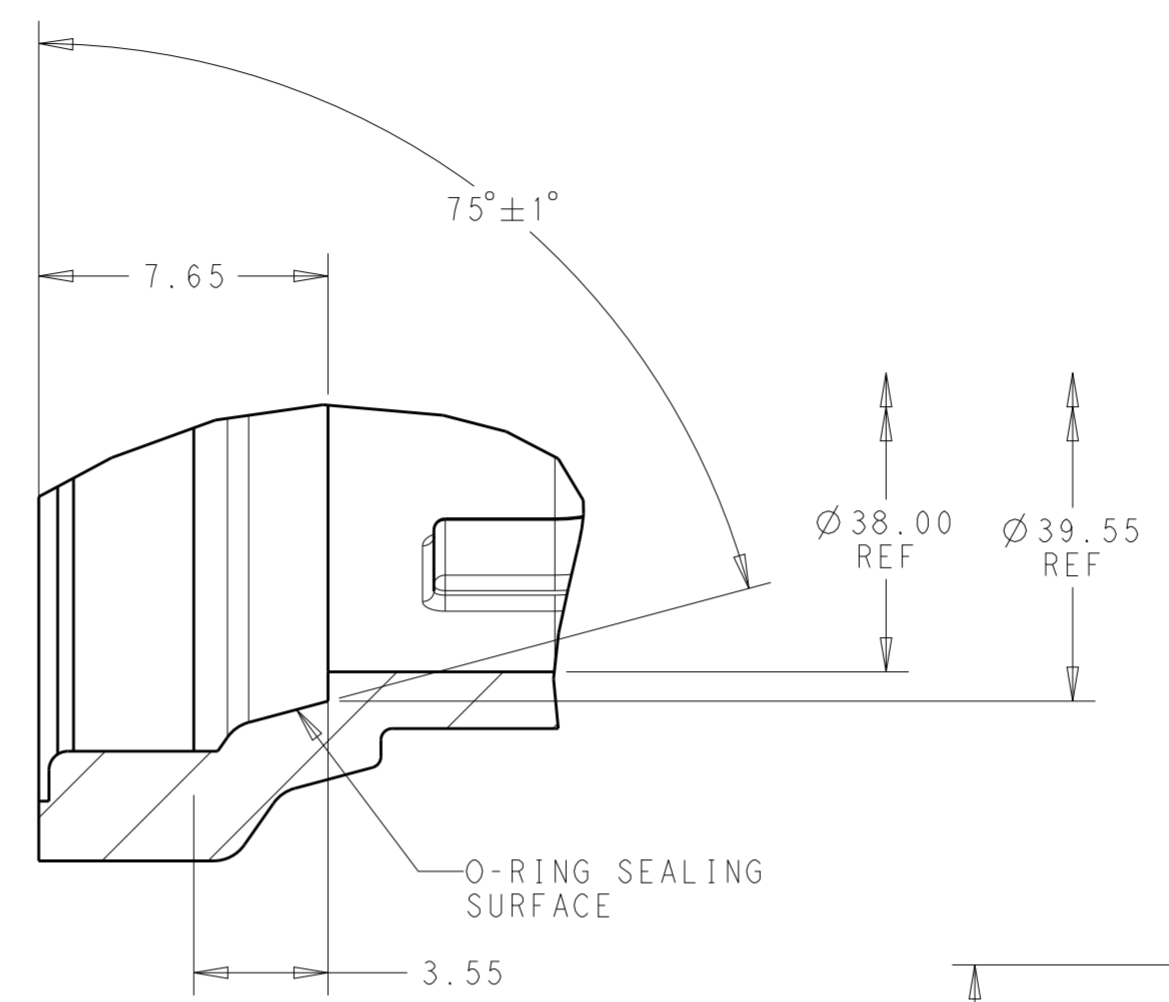

SECTION C-C
SCALE 5:1

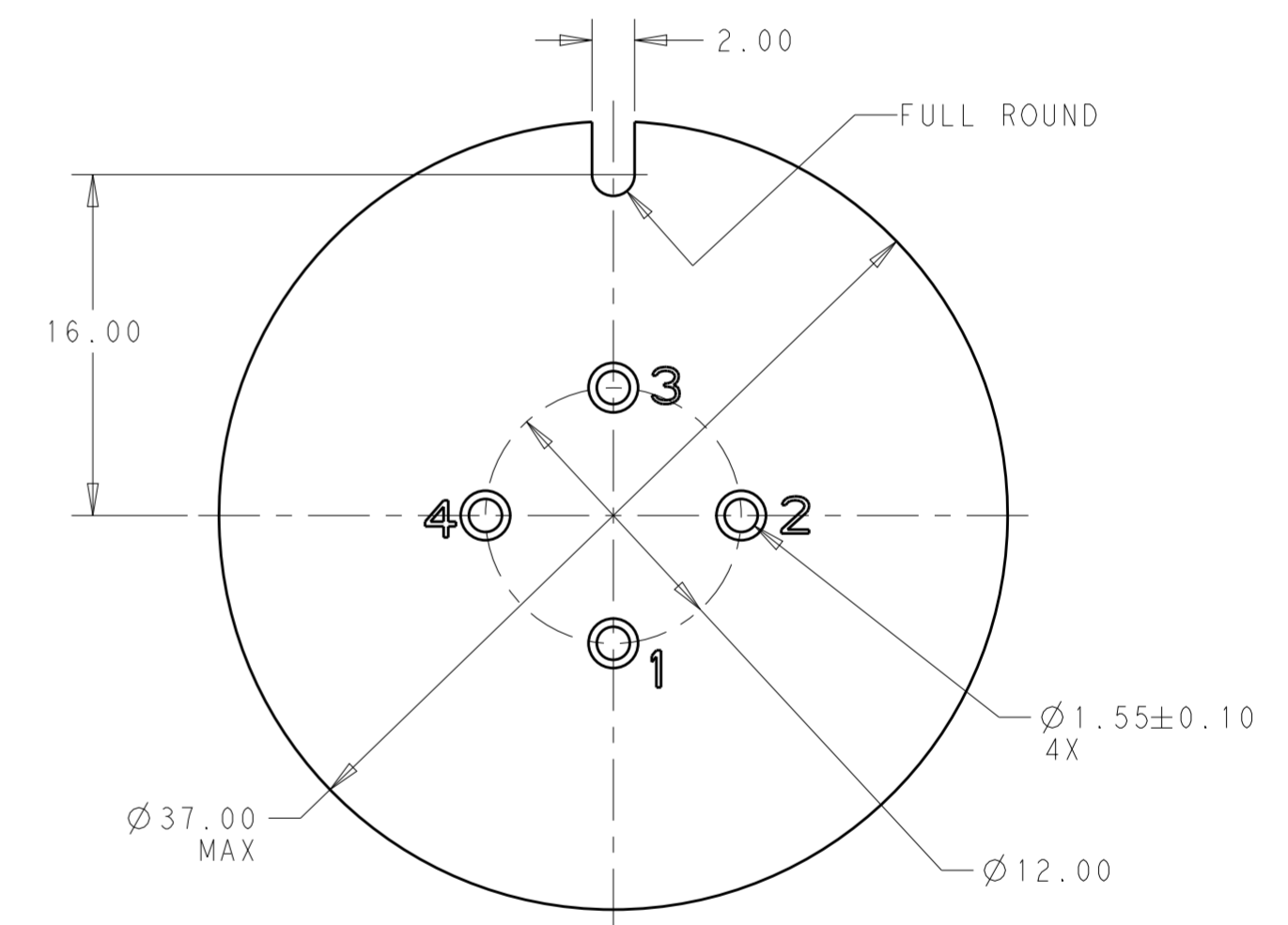
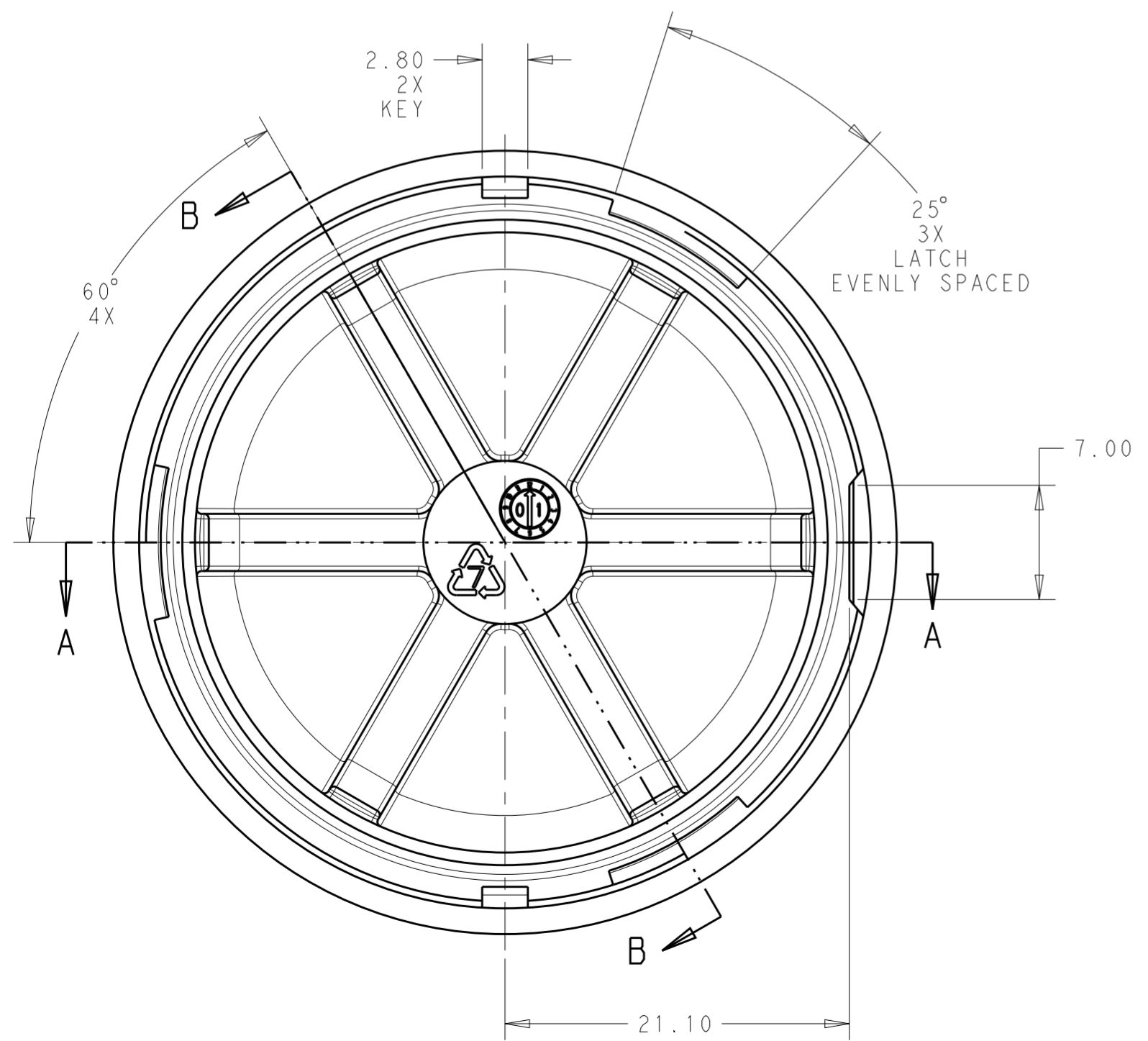

PROPOSED PCB LAYOUT
SCALE 3:1

THIS DRAWING IS A CONTROLLED DOCUMENT.		DWN C. DAILY 03OCT2018	TE Connectivity	
		CHK M. MOSTOLLER 03OCT2018		
DIMENSIONS:	TOLERANCES UNLESS OTHERWISE SPECIFIED:	APVD -	NAME MODULE BASE ASSEMBLY, LUMAWISE ENDURANCE S 40mm DIAMETER, KEYED	
mm	0 PLC ± 1 PLC ±0.2 2 PLC ±0.15 3 PLC ±0 4 PLC ±0	PRODUCT SPEC 108-133073	SIZE A2	CAGE CODE -
	ANGLES ±1° FINISH -	APPLICATION SPEC 114-133074	DRAWING NO C-2343405	RESTRICTED TO -
MATERIAL SEE NOTES	-	WEIGHT -	SCALE 1:1	SHEET 3 OF 3
		CUSTOMER DRAWING	REV A	