

GENERAL TOLERANCE										USED ON
10 MAX	30 MAX	50 MAX	70 MAX	100 MAX	120 MAX	250 MAX	250 OVER	ANGLE	ECCENT	
±0.15	±0.20	±0.30	±0.40	±0.50	±0.75	±0.90	±1.4	±0.5°	0.1	

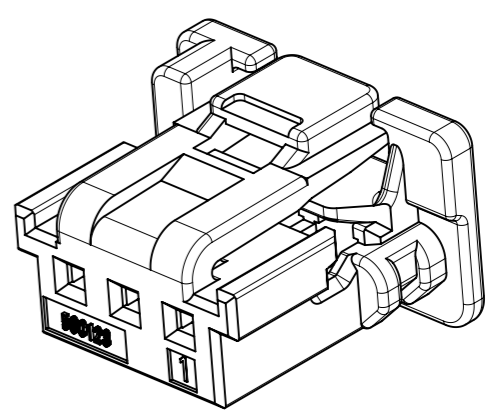

ISO VIEW

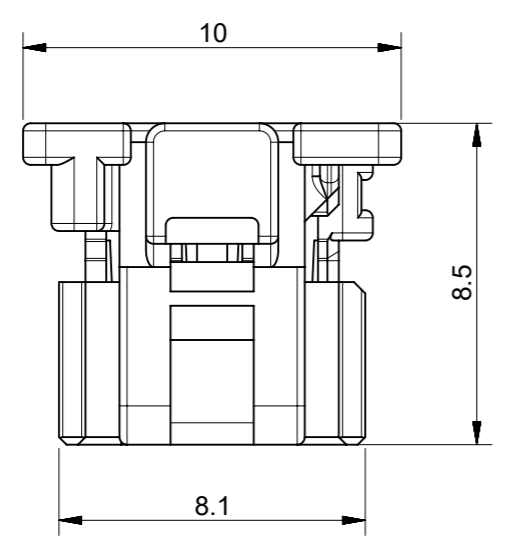
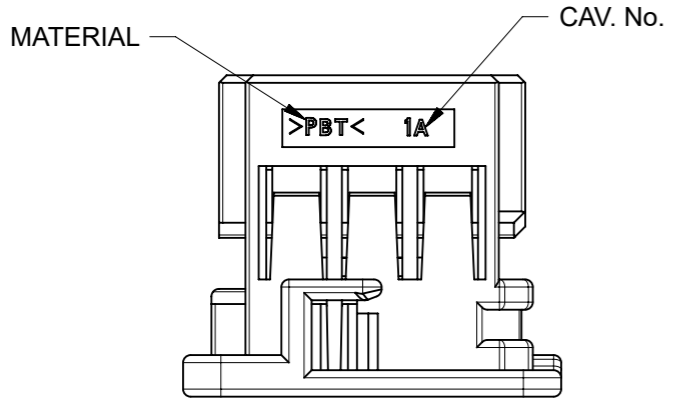
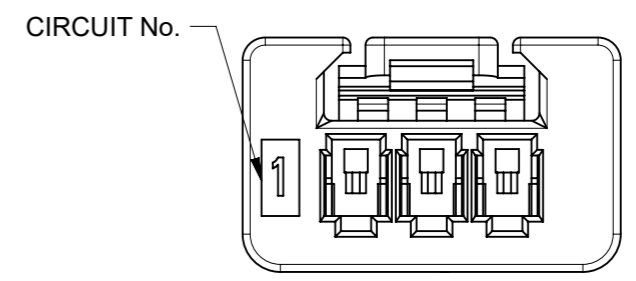
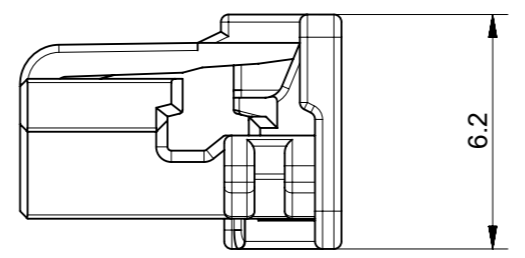
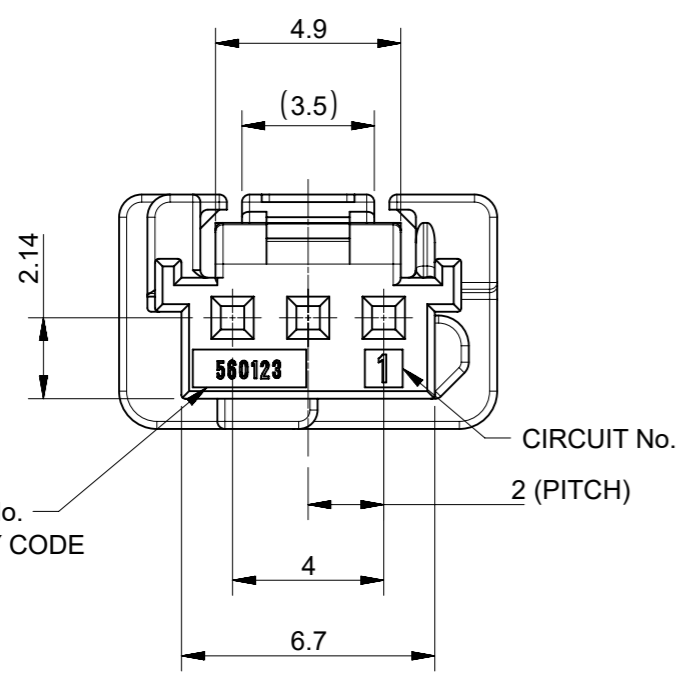

PENDING APPROVAL

- NOTES:
1. MATERIALS : POLYESTER (PBT), GLASS UNFILLED, UL 94V-0
 2. MATE WITH : 502352, 560020 SERIES
 3. APPLICABLE TERMINAL : 560124 SERIES
 4. APPLICABLE ISL : 560125 SERIES
 5. GENERAL TOLERANCE : SEE TABLE
 6. EVL AND RoHS COMPLIANT
 7. PRODUCT SPECIFICATION : PS-560123-001,002,003
 8. PACKING SPECIFICATION : PK-560123-001

ORDER NO.	MATERIAL NO.	COLOR
560123-0300	5601230300	WHITE
560123-0301	5601230301	BLACK
560123-0302	5601230302	RED
560123-0304	5601230304	BLUE

SYMBOLS		THIS DRAWING CONTAINS INFORMATION THAT IS PROPRIETARY TO MOLEX ELECTRONIC TECHNOLOGIES, LLC AND SHOULD NOT BE USED WITHOUT WRITTEN PERMISSION		CURRENT REV DESC:	
▽ = 0	mm	SCALE	5:1	EC NO: 629104	
▽ = 0	GENERAL TOLERANCES (UNLESS SPECIFIED)			DRWN: SAKIM	2019/12/11
▽ = 0	ANGULAR TOL ± °			CHK'D:	
▽ = 0	4 PLACES ±			APPR:	
▽ = 0	3 PLACES ±			INITIAL REVISION:	
▽ = 0	2 PLACES ±			DRWN: YIBAEK	2014/07/08
▽ = 0	1 PLACE ±			APPR: SRTAK	2014/08/26
▽ = 0	0 PLACES ±			THIRD ANGLE PROJECTION	
▽ = 0	DRAFT WHERE APPLICABLE MUST REMAIN WITHIN DIMENSIONS			DRAWING	SERIES
				A3-SIZE	560123
DOCUMENT NUMBER		DOC TYPE		DOC PART	
SD-560123-003		PSD		001 C1	
MATERIAL NUMBER		CUSTOMER		SHEET NUMBER	
560123		GENERAL MARKET		1 OF 1	

DOCUMENT STATUS	RQ	RELEASE DATE