

REVISIONS				
P.	LTN	DESCRIPTION	DATE	APP'D
A7		REVISED PER ECO-15-003872	25MAR2015	DD DS
A8		REVISED PER ECO-19-019419	20JUN2019	DS DS

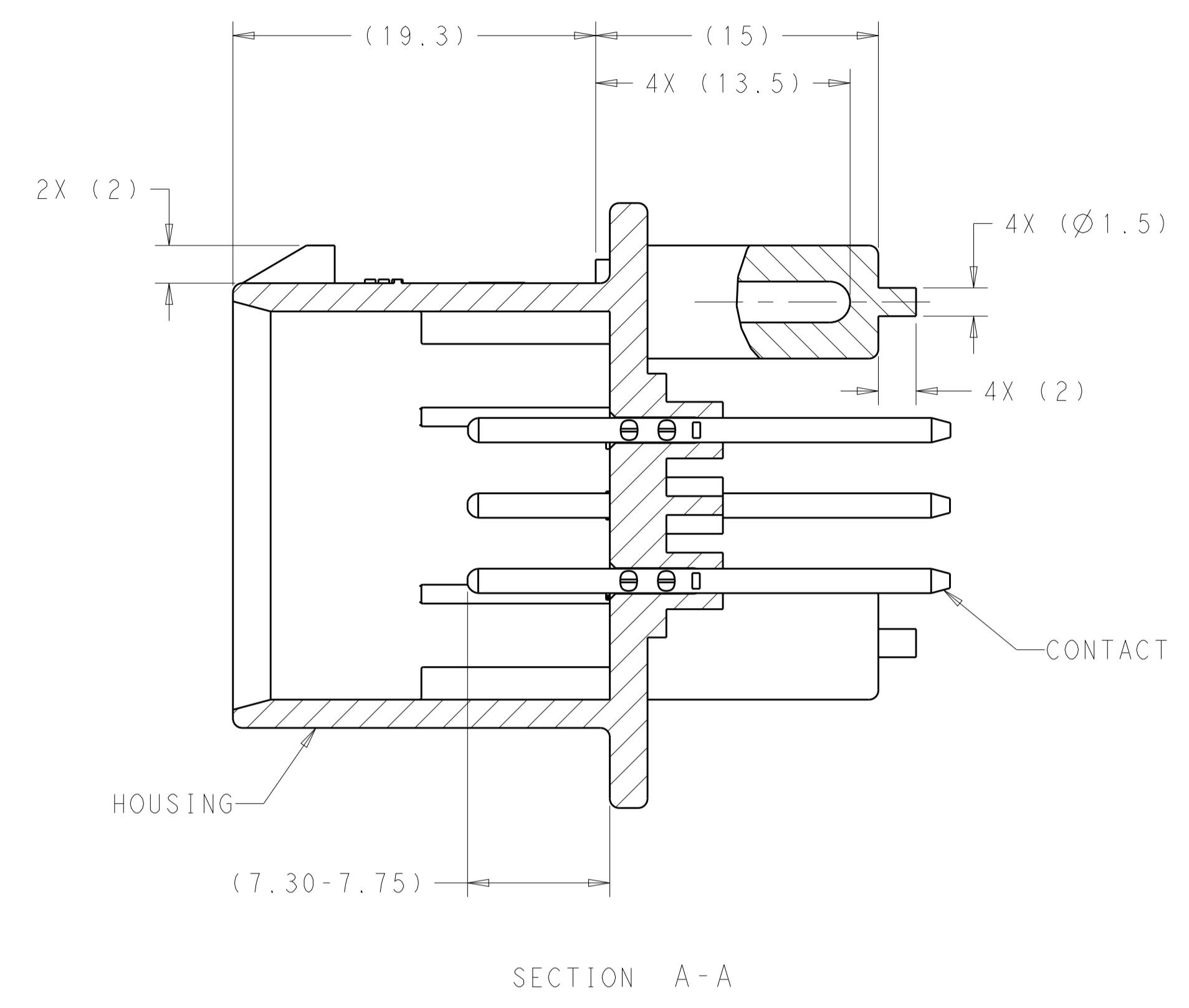

- △ ACCEPTS SCREW SIZE [Ø0.99 (2.50mm)] SELF TAPPING THREAD FORMING SCREW TO BE DRIVEN AT 0.6-0.8 N-m.
- △ DATE CODE IN THIS LOCATION USING 5 DIGIT CODE  
 FIRST 2 DIGITS = YEAR, SECOND 2 DIGITS = WEEK  
 LAST DIGIT = DAY.
- △ MATERIALS: HEADER HOUSING - GLASS FILLED PBT  
 PINS - TIN OR GOLD PLATED BRASS
- △ HOUSING COLORS ARE MECHANICALLY KEYS TO MATE ONLY WITH IDENTICALLY COLORED PLUG ASSEMBLIES.
- 5. HEADER MATES TO PLUG ASSEMBLY 776273 WHICH USES REELED TERMINAL 770520 OR LOOSE PIECE TERMINAL 770854

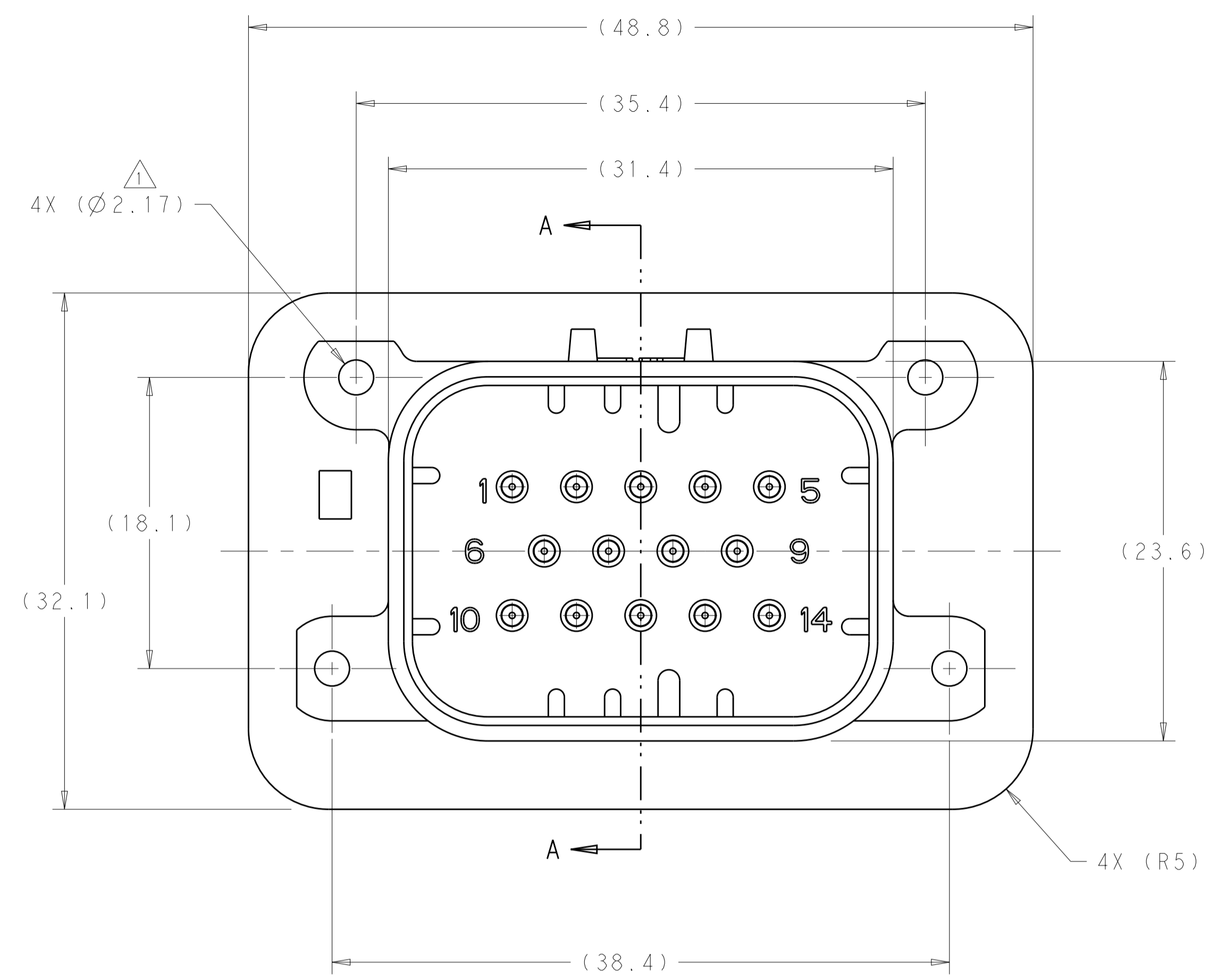
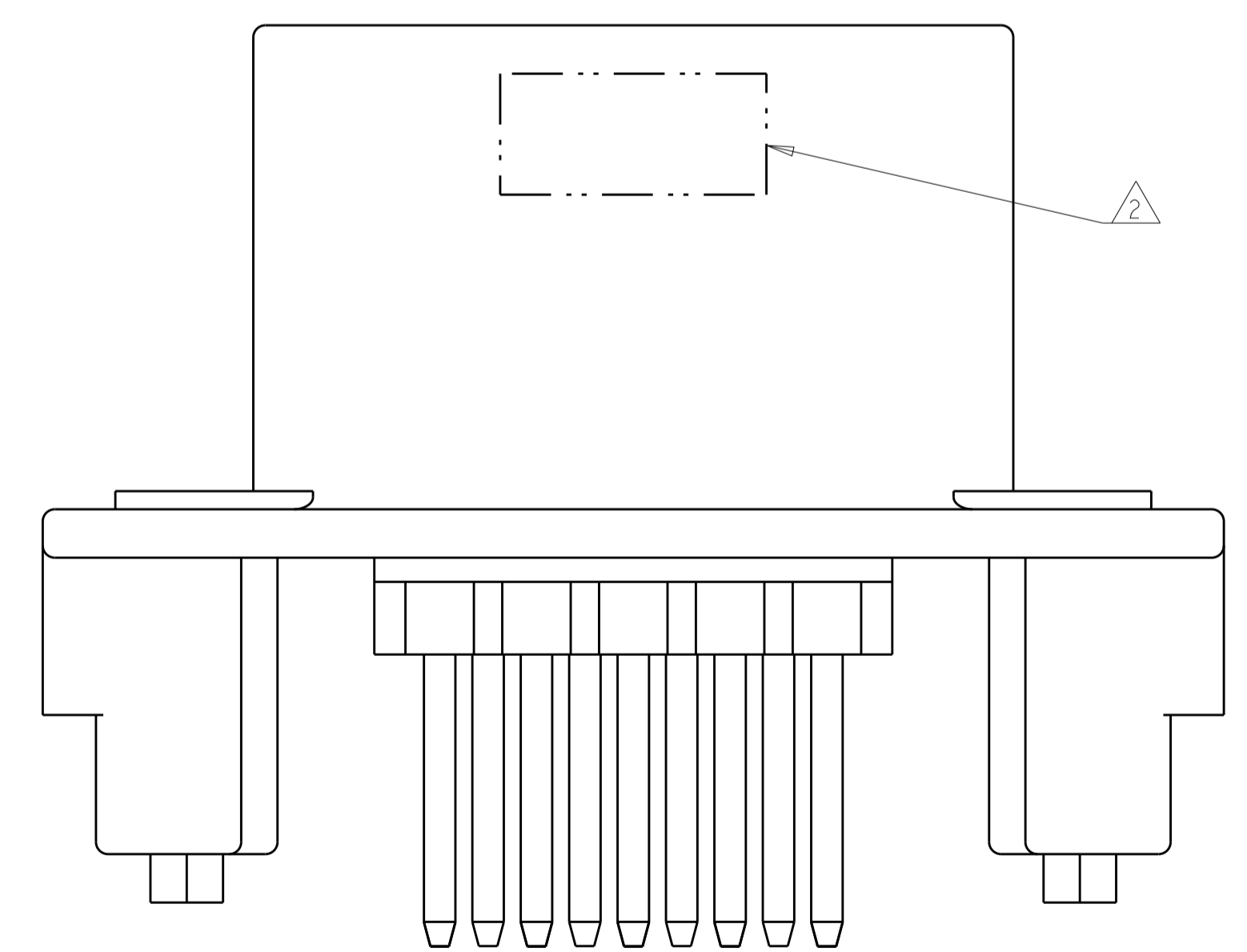

776261-1 & 1-776261-1 SHOWN

HEADER COLOR	PLATING	PART NUMBER
BLUE	GOLD	1-776261-5
GRAY	GOLD	1-776261-4
NATURAL	GOLD	1-776261-2
BLACK	GOLD	1-776261-1
BLUE	TIN	776261-5
GRAY	TIN	776261-4
NATURAL	TIN	776261-2
BLACK	TIN	776261-1

THIS DRAWING IS A CONTROLLED DOCUMENT.

DIMENSIONS:	TOLERANCES UNLESS OTHERWISE SPECIFIED:	OWN: D. STRAUSSER 04FEB2010	CHK: D. STRAUSSER 22MAR2010	APVD: D. STRAUSSER 27APR2010
mm	0 PLC ±0.2	NAME: D. STRAUSSER		
		PRODUCT SPEC: 108-1329		
		APPLICATION SPEC: 114-16016		
		WEIGHT: 16.90g		
		CUSTOMER DRAWING		

TE Connectivity  
**TE**  
 HEADER ASSEMBLY, 14 POSITION, VERTICAL, AMPSEAL

SIZE: A1 CAGE CODE: 00779 DRAWING NO: 776261 RESTRICTED TO: -  
 SCALE: 4:1 SHEET 1 OF 2 REV: A8

REVISIONS				
P.	LTN.	DESCRIPTION	DATE	APVD.
-	-	SEE SHEET 1	-	-

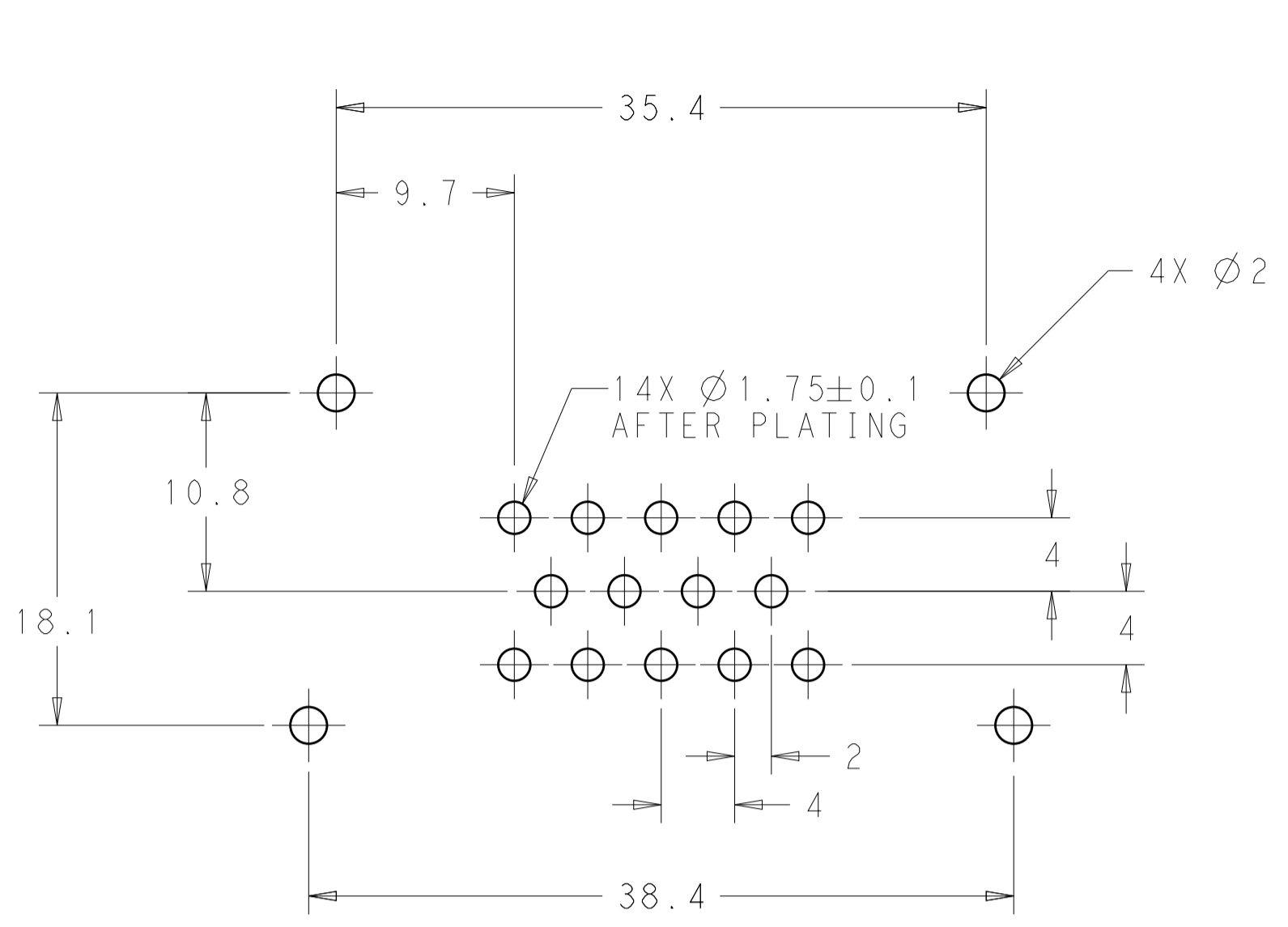

RECOMMENDED P.C. BOARD LAYOUT FOR 1.57 THICK P.C. BOARD

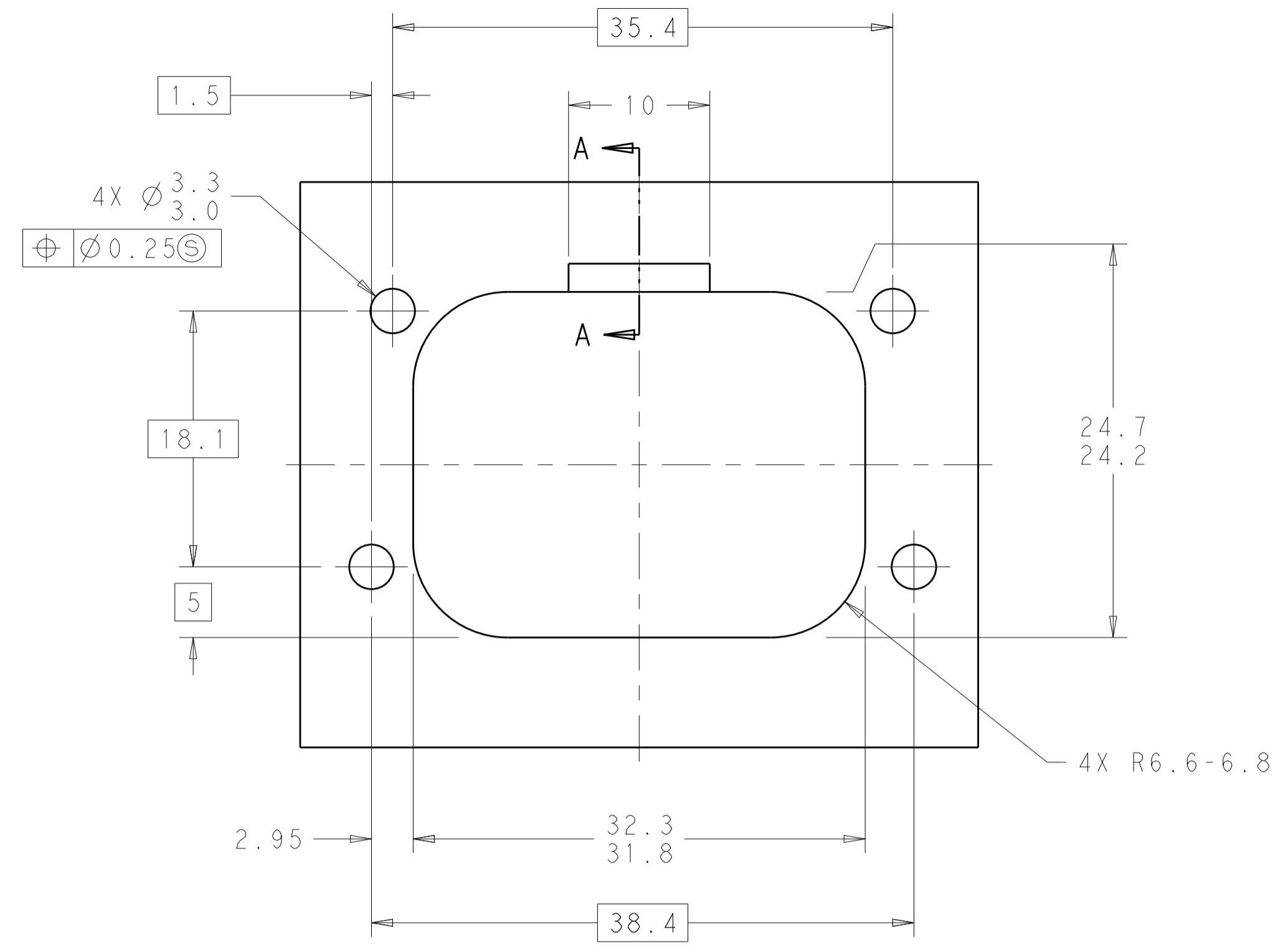

RECOMMENDED MOUNTING HOLE LAYOUT FOR 5.0 MAX THICK PANEL

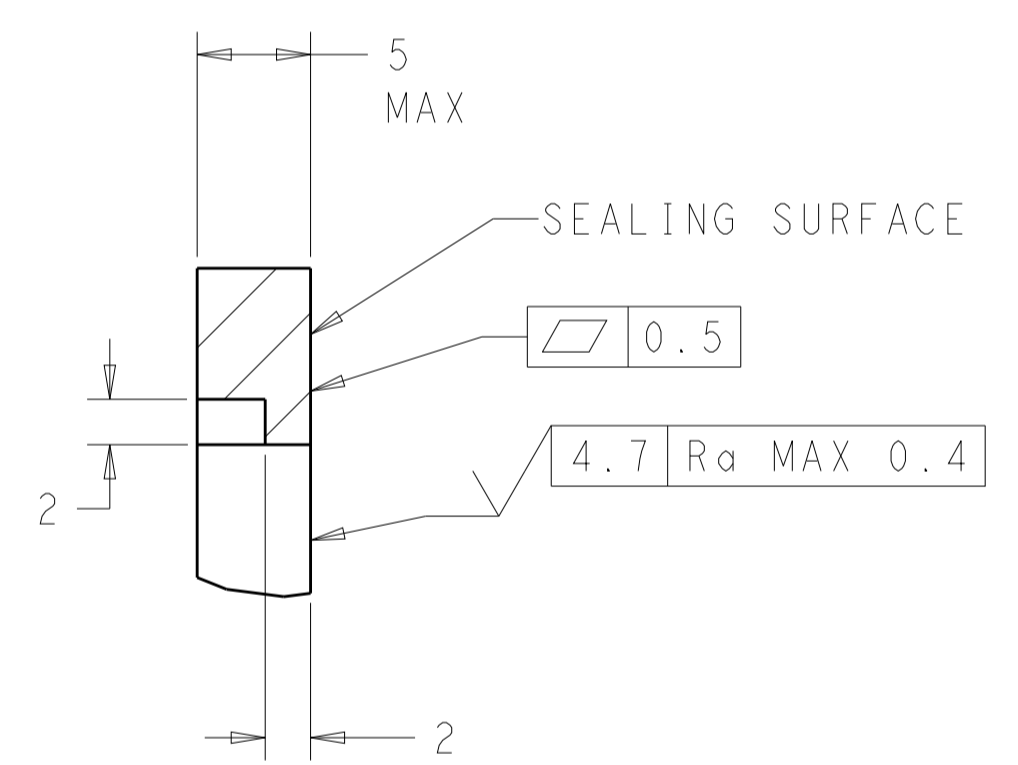
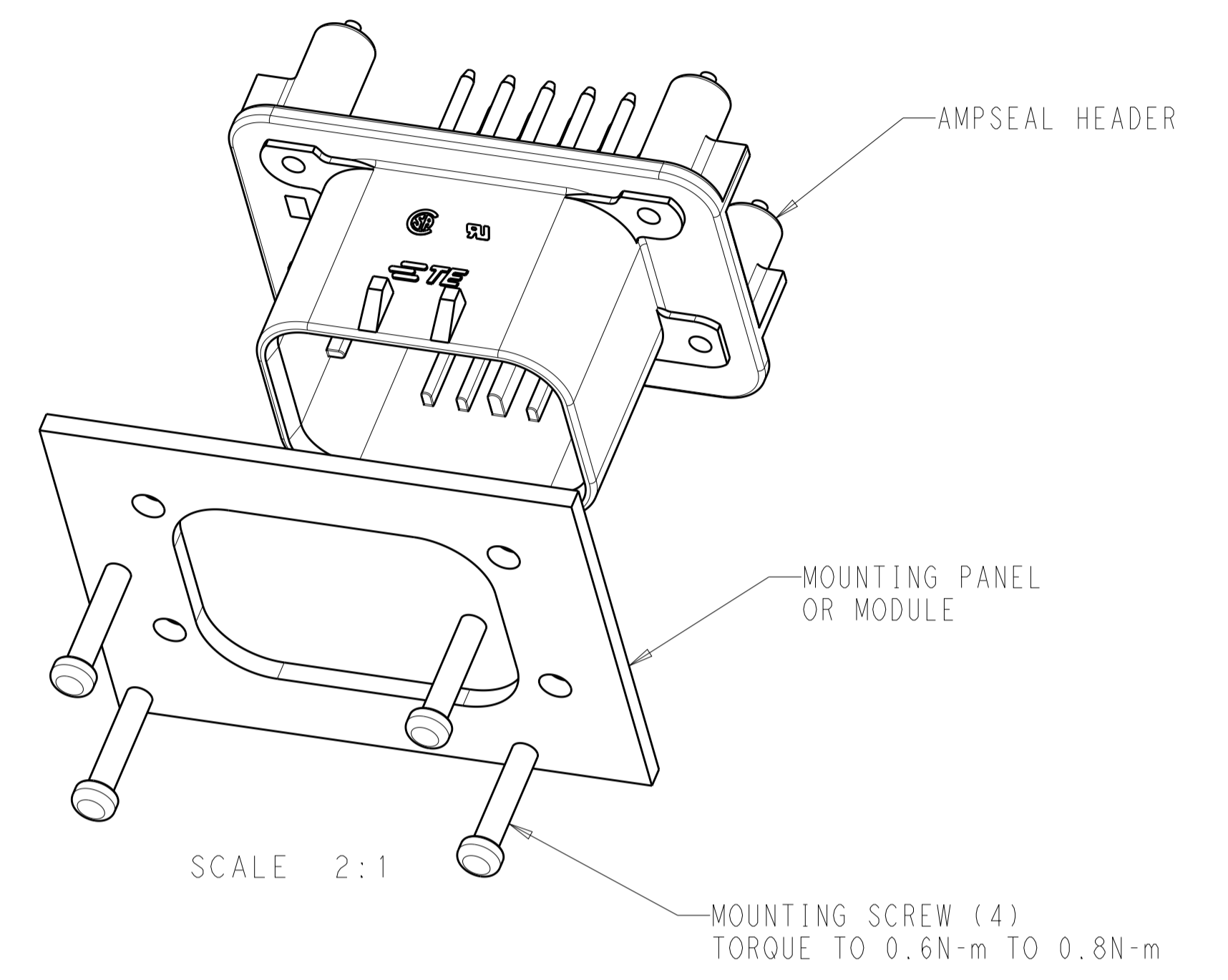

SECTION A-A  
OPTIONAL CONSTRUCTION IF PANEL THICKNESS IS GREATER THAN 2.0

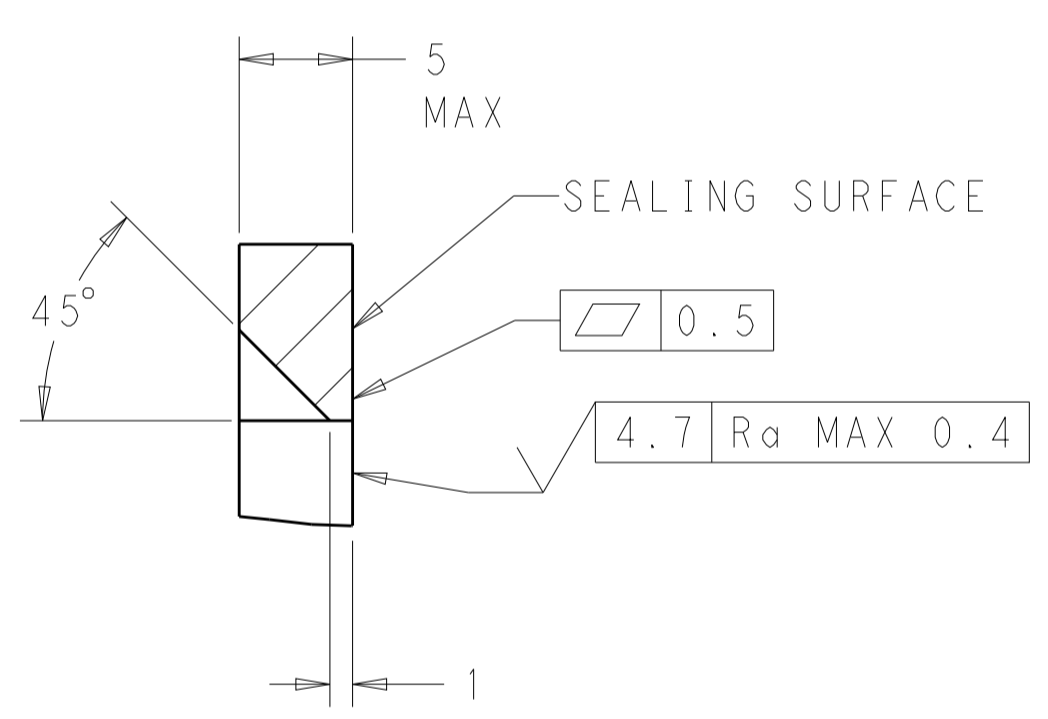

SECTION A-A  
OPTIONAL CONSTRUCTION IF PANEL THICKNESS IS GREATER THAN 2.0

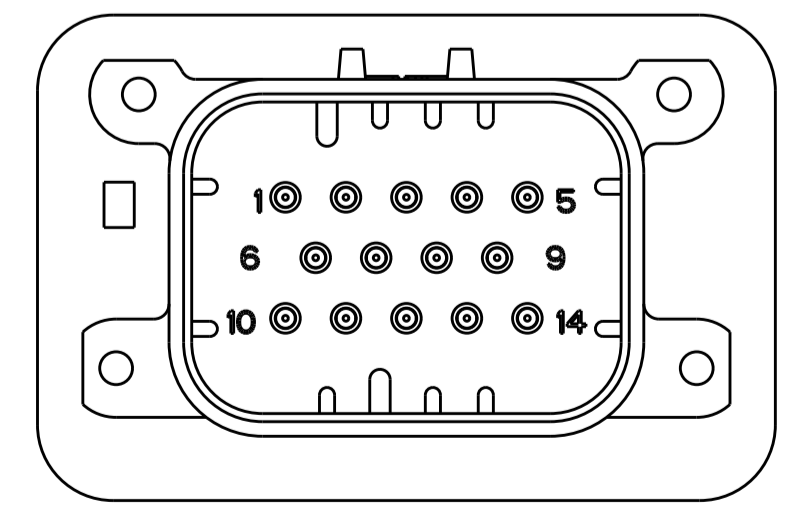
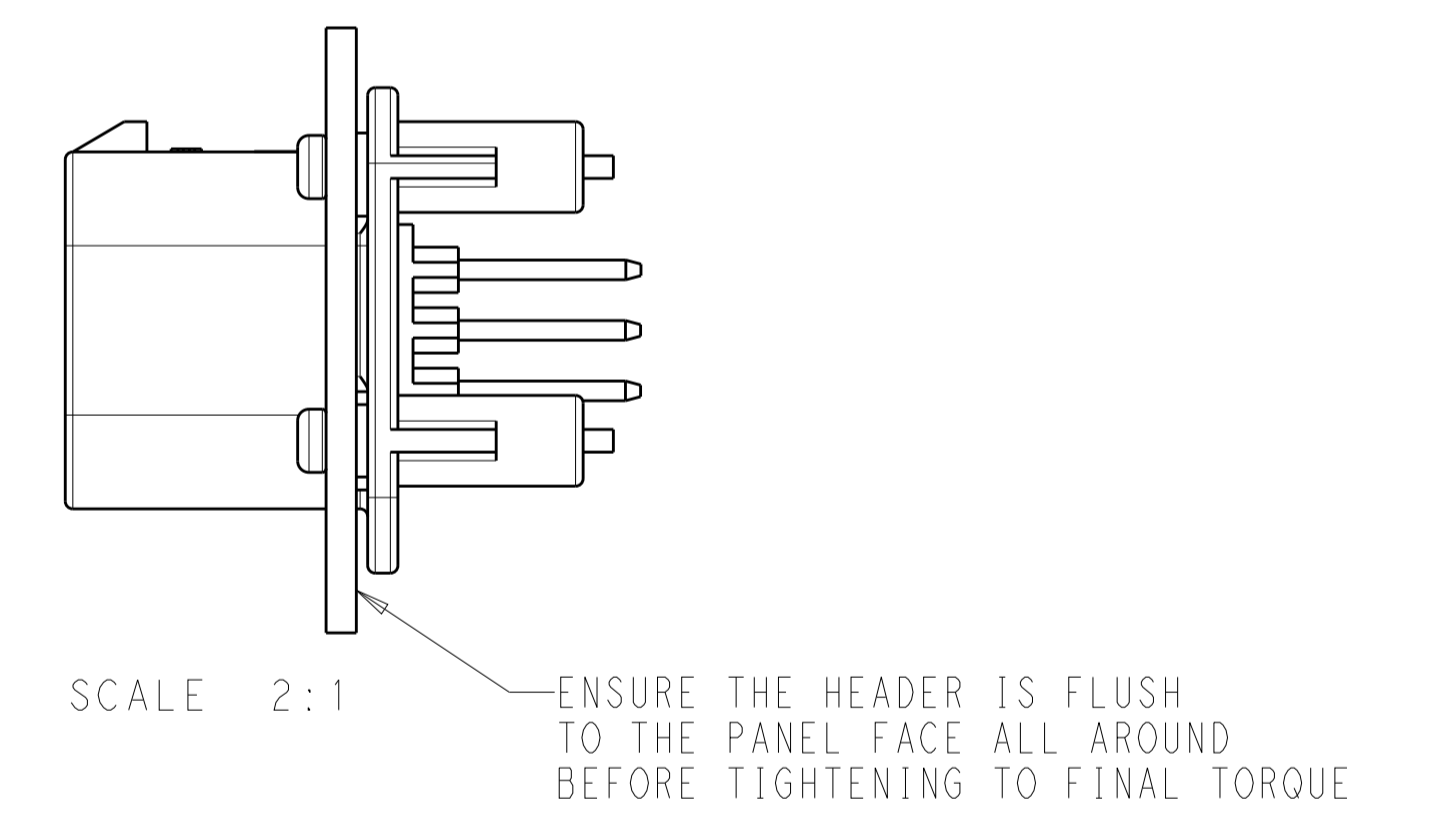

776261-2 & 1-776261-2  
KEY LOCATION  
SCALE 2:1

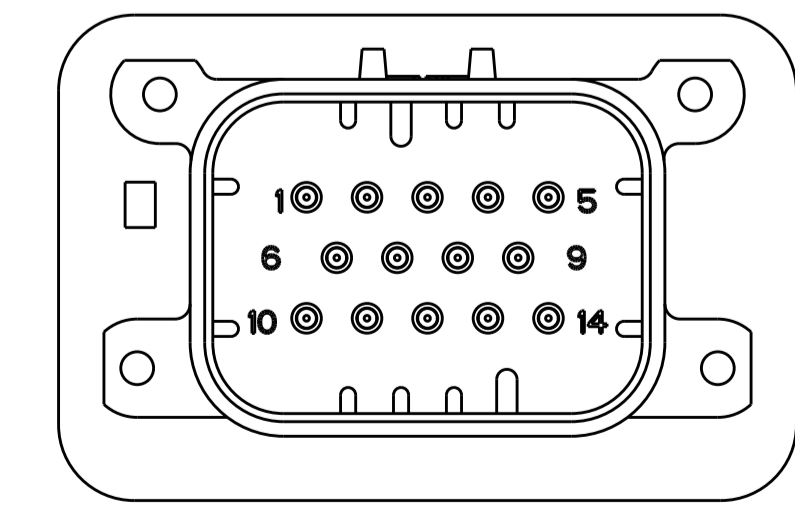

776261-4 & 1-776261-4  
KEY LOCATION  
SCALE 2:1

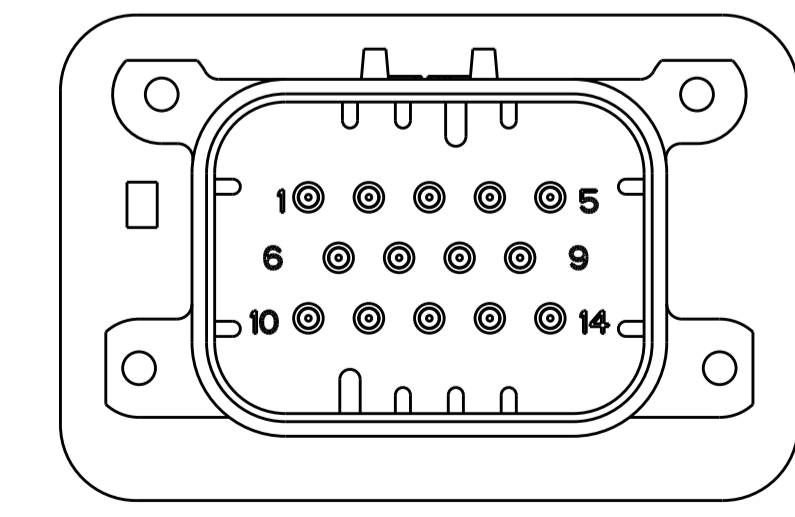

776261-5 & 1-776261-5  
KEY LOCATION  
SCALE 2:1

THIS DRAWING IS A CONTROLLED DOCUMENT.		DWN: D. STRAUSSER 04FEB2010 CHK: D. STRAUSSER 22MAR2010 APVD: D. STRAUSSER 27APR2010	TE Connectivity	
DIMENSIONS: mm 		TOLERANCES UNLESS OTHERWISE SPECIFIED: 0 PLC ± 1 PLC ±0.2 2 PLC ± 3 PLC ± 4 PLC ± ANGLES ±		NAME: HEADER ASSEMBLY, 14 POSITION, VERTICAL, AMPSEAL PRODUCT SPEC: 108-1329 APPLICATION SPEC: 114-16016 WEIGHT: 16.90g
MATERIAL: -		FINISH: -		SIZE: A1 CAGE CODE: 776261 CUSTOMER DRAWING: - SCALE: 4:1 SHEET 2 OF 2 REV: A8