

THIS DRAWING IS UNPUBLISHED. RELEASED FOR PUBLICATION
 © COPYRIGHT - By - ALL RIGHTS RESERVED.

REVISIONS					
P	LTR	DESCRIPTION	DATE	DWN	APVD
	AB	REVISED PER ECO-14-015277	16FEB2015	NK	DR
	AB1	REVISED PER ECO-17-007400	19DEC2017	RS	DR

AMP WIRE RANGE	E13288 Listed	LR7189 Certified
22-16 AWG SOLID OR STRANDED	22-16 AWG SOLID OR STRANDED	22-16 AWG SOLID OR STRANDED

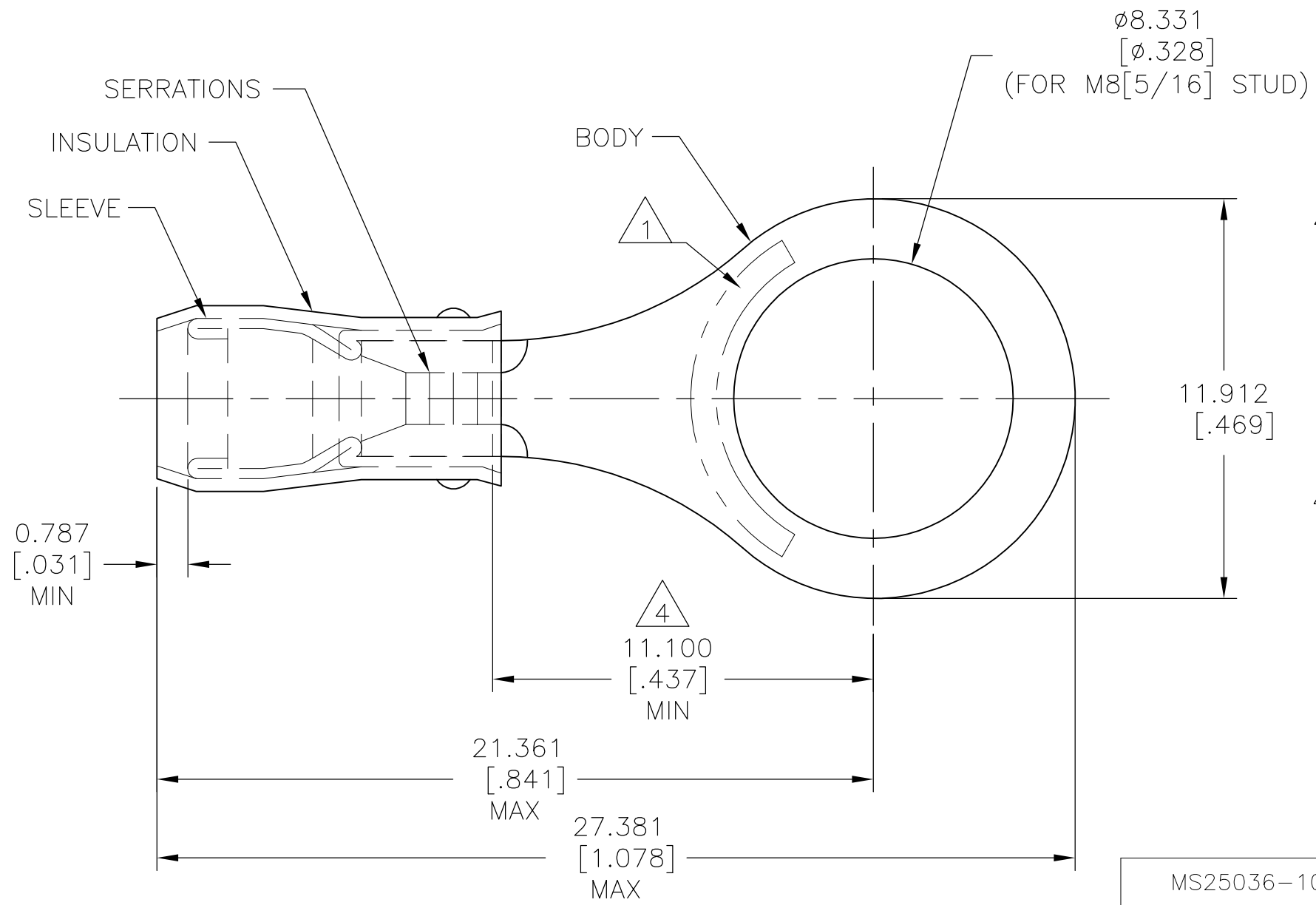

- 1 STAMP AMP 22-18* APPROX AS SHOWN
22-16 TERMINALS ARE STAMPED 22-18 IN
ACCORDANCE WITH MILITARY SPEC SAE AS7928
COMMERCIAL WIRE RANGE IS 22-16.
- 2 WIRE INSULATION : $\phi 2.032-3.175[\phi .080-.125]$.
- 3 BODY MATERIAL THK: $0.787\pm 0.051[.031\pm .002]$.
- 4 APPLIES FROM EDGE OF METAL WIRE BARREL
TO CENTER OF STUD HOLE.

MS25036-104 CLASS 2	5000	ON TAPE, REEL	2-320572-1
MS25036-104 CLASS 1 & 2	1000	LOOSE PIECE	320572
MILITARY P/N AND CLASS	QUANTITY	PACKAGE TYPE	PART NO

AMP INCORPORATED CUSTOMER SERVICE SYSTEMS		MAX RECOMMENDED OPERATING TEMPERATURE: 105°C[221°F] MAX
FOR ADDITIONAL PRODUCT INFORMATION OR COPIES OF DRAWINGS AND TECHNICAL DOCUMENTS	PRODUCT INFORMATION CENTER 1-800-522-6752	VOLTAGE RATING: 300 V MAX
FOR APPLICATION TOOLING INFORMATION	TOOLING ASSISTANCE CENTER 1-800-722-1111	CIRCULAR MIL AREA: 0.26-1.65mm ² [509-3,260] CIR MILS SOLID OR STRANDED
FOR ORDER ENTRY	1-800-526-5142	THIS DRAWING IS A CONTROLLED DOCUMENT FOR AMP INCORPORATED. IT IS SUBJECT TO CHANGE AND THE CONTROLLING ENGINEERING ORGANIZATION SHOULD BE CONTACTED FOR THE LATEST REVISION.

THIS DRAWING IS A CONTROLLED DOCUMENT.		DWN DK SCHRUM 9/8/93	TE Connectivity	
DIMENSIONS: mm [INCHES]		CHK RE HERSEY 9/8/93		
TOLERANCES UNLESS OTHERWISE SPECIFIED:		APVD ML ELLIS 9/8/93	NAME TERMINAL, RING TONGUE, PIDG™, WIRE SIZE, 22-16 AWG	
0 PLC ± - 1 PLC ± - 2 PLC ± - 3 PLC ± 0.127[.005] 4 PLC ± - ANGLES ± -		PRODUCT SPEC UL 486 A-B	SIZE A3	
MATERIAL COPPER PER ASTM B-152 SLEEVE, RED NYLON		APPLICATION SPEC 114-2157	CAGE CODE 00779	DRAWING NO C-320572
FINISH TIN PLATE PER ASTM B 545		WEIGHT -	RESTRICTED TO -	
CUSTOMER DRAWING		SCALE 6:1	SHEET 1 OF 2	REV AB1

REVISIONS					
P	LTR	DESCRIPTION	DATE	DWN	APVD
-	-	SEE SHEET 1	-	-	-

AMP
WIRE RANGE

SEE TABLE
STRANDED

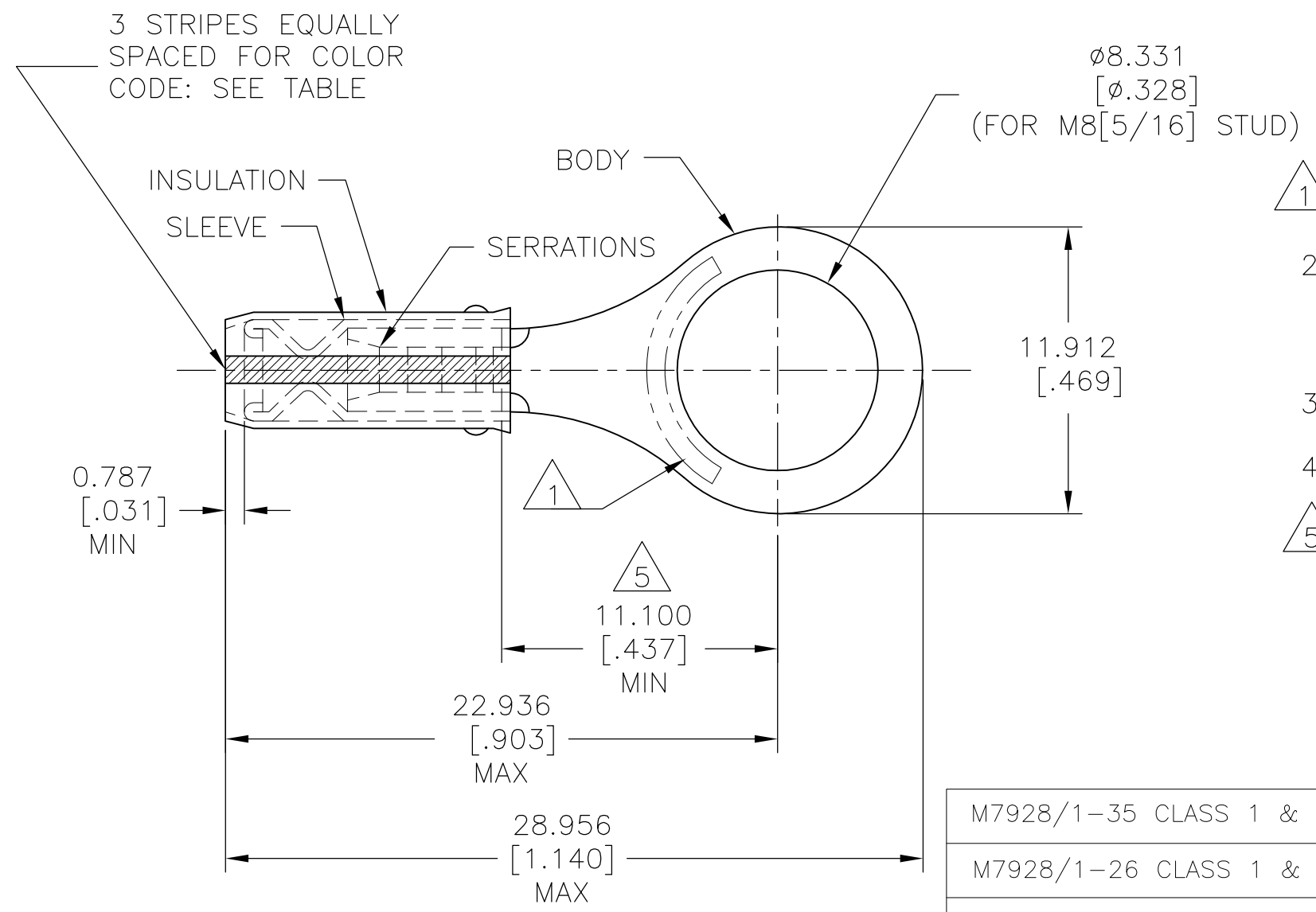

- 1 STAMP AMP APPROX AS SHOWN SEE TABLE BELOW.
- 2 WIRE INSULATION : $\phi 0.965-2.794[\phi 0.038-.110]$ FOR 22 AWG
 $\phi 1.168-2.794[\phi 0.046-.110]$ FOR 20 AWG
 $\phi 1.422-2.794[\phi 0.056-.110]$ FOR 18 AWG.
- 3 BODY MATERIAL THK: $0.787 \pm 0.051[.031 \pm .002]$.
- 4 NOTE DELETED.
- 5 APPLIES FROM EDGE OF METAL WIRE BARREL TO CENTER OF STUD HOLE.

M7928/1-35 CLASS 1 & 2	WHITE	18*	18	1000	LOOSE PIECE	2-320572-4
M7928/1-26 CLASS 1 & 2	RED	20*	20	1000	LOOSE PIECE	2-320572-3
M7928/1-17 CLASS 1 & 2	GREEN	22*	22	1000	LOOSE PIECE	2-320572-2
MILITARY P/N AND CLASS	STRIPE COLOR	STAMPING	WIRE SIZE	QUANTITY	PACKAGE TYPE	PART NO

AMP INCORPORATED CUSTOMER SERVICE SYSTEMS		MAX RECOMMENDED OPERATING TEMPERATURE: 105°C[221°F] MAX		THIS DRAWING IS A CONTROLLED DOCUMENT.		STE TE Connectivity	
FOR ADDITIONAL PRODUCT INFORMATION OR COPIES OF DRAWINGS AND TECHNICAL DOCUMENTS	PRODUCT INFORMATION CENTER 1-800-522-6752	VOLTAGE RATING: 300 V MAX	WIRE RANGE: CIRC MIL AREA	DIMENSIONS: mm [INCHES]	TOLERANCES UNLESS OTHERWISE SPECIFIED:	NAME TERMINAL, RING TONGUE, I.R., PIDG, WIRE SIZE: 22, 20 & 18 AWG	
FOR APPLICATION TOOLING INFORMATION	TOOLING ASSISTANCE CENTER 1-800-722-1111	22 0.38mm ² [754]	20 0.60mm ² [1,186]		0 PLC ± - 1 PLC ± - 2 PLC ± - 3 PLC ± 0.127[.005] 4 PLC ± - ANGLES ± -	APVD ML ELLIS 9/8/93	PRODUCT SPEC
FOR ORDER ENTRY	1-800-526-5142	18 0.96mm ² [1,900]	STRANDED	MATERIAL	FINISH	APVD RE HERSEY 9/8/93	APPLICATION SPEC
THIS DRAWING IS A CONTROLLED DOCUMENT FOR AMP INCORPORATED. IT IS SUBJECT TO CHANGE AND THE CONTROLLING ENGINEERING ORGANIZATION SHOULD BE CONTACTED FOR THE LATEST REVISION.		COPPER PER ASTM B-152 SLEEVE, RED NYLON		TIN PLATE PER ASTM B 545		NOT AVAILABLE	WEIGHT -
				CUSTOMER DRAWING		SIZE A3	CAGE CODE 00779
						DRAWING NO C-320572	RESTRICTED TO -
						SCALE 4:1	SHEET 2 OF 2
						REV AB1	