

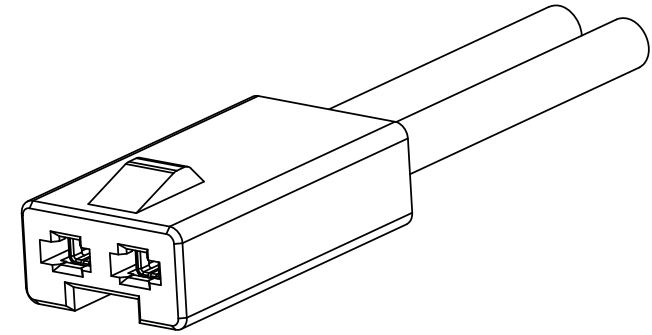

REVISIONS			
REV	DESCRIPTION, ECN, EAR NO.	DATE	APPD
B	PART NUMBER UPDATED	SEP09/19	S.M
C	XX OPTIONS ADDED	JUN16/20	S.M

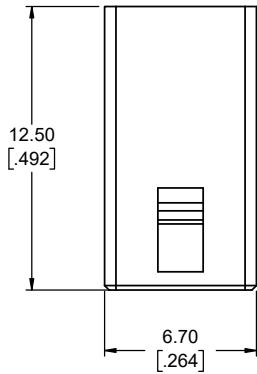

APPLICATION VIEW

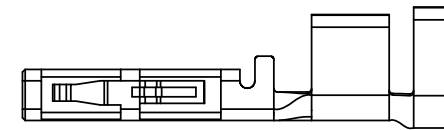
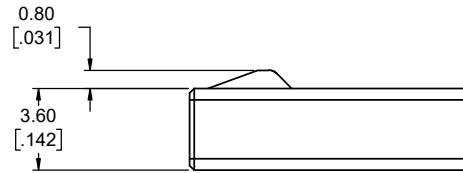
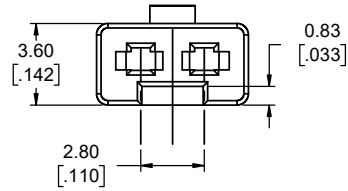

FLH-SC136-T01 - SOCKET CONTACT
SEE NOTES 3 & 4
SCALE 10:1

NOTES:

- MATERIALS: ALL MATERIALS ARE RoHS COMPLIANT PER EU DIRECTIVE 2011/65/EU & AMENDMENTS
 - HOUSING: ENGINEERING THERMOPLASTIC, UL FLAMMABILITY RATING 94V-0, COLOUR BLACK
- ELECTRICAL CHARACTERISTICS
 - CURRENT RATING: 7A (18 AWG) OR 5A (20 AWG) OR 3A (22 AWG) PER CONTACT
 - DIELECTRIC WITHSTANDING VOLTAGE: 1000 VAC
 - INSULATION RESISTANCE: 500 MEGAOHMS
 - OPERATING TEMPERATURE: -40°C TO +105°C
- CRIMP WIRE TO CONTACT BEFORE ASSEMBLING INTO HOUSING.
- SOCKET CONTACTS TO BE PURCHASED SEPARATELY ON REEL. P/N: FLH-SC136-T01

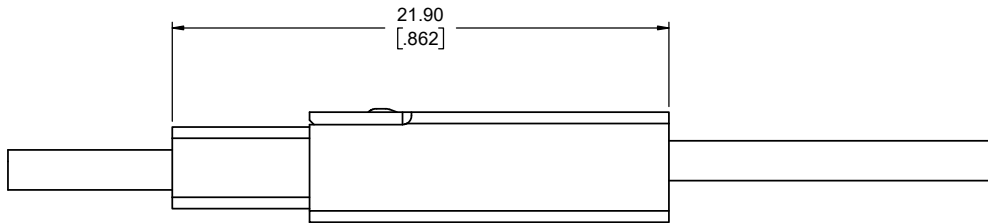

MATED ASSEMBLY FLM-2X2-00

AMPHENOL PART NUMBER: **FLM-S21-XX**

XX = 00 - BLACK HOUSING (STANDARD)
XX = W0 - WHITE HOUSING
XX = 01-99 CUSTOM CONFIGURATIONS

UNLESS SPECIFIED OTHERWISE	DRAWN	I.NELSON	JUL23/19
PRIMARY UNITS MILLIMETERS	CHECKED	S.MUGAN	AUG19/19
SECONDARY INCHES	M.E. APPD		
REFERENCE IN PARENTHESES	Q.A. APPD		
GENERAL TOLERANCES	DWG APPR.		
1 DECIMAL PLACE	ENG. REL. NO.		
2 DECIMAL PLACES ±0.10	REF.		
3 DECIMAL PLACES	THIRD ANGLE PROJECTION		
ANGULAR DEGREES	DO NOT SCALE DRAWING		

Amphenol Canada Corp.
Commercial Products
FLM SERIES, PLUG WITH CRIMP CONTACTS
RoHS COMPLIANT

DWG. NO.	REV
P-FLM-S21-XX	C
CODE ID NO. 03554	DWG SIZE: X
SCALE: 5:1	SHEET 1 OF 1