

Aug.1.2020 Copyright 2020 HIROSE ELECTRIC CO., LTD. All Rights Reserved.  
In case of consideration for using Automotive equipment / device which demand high reliability, kindly contact our sales window correspondents.

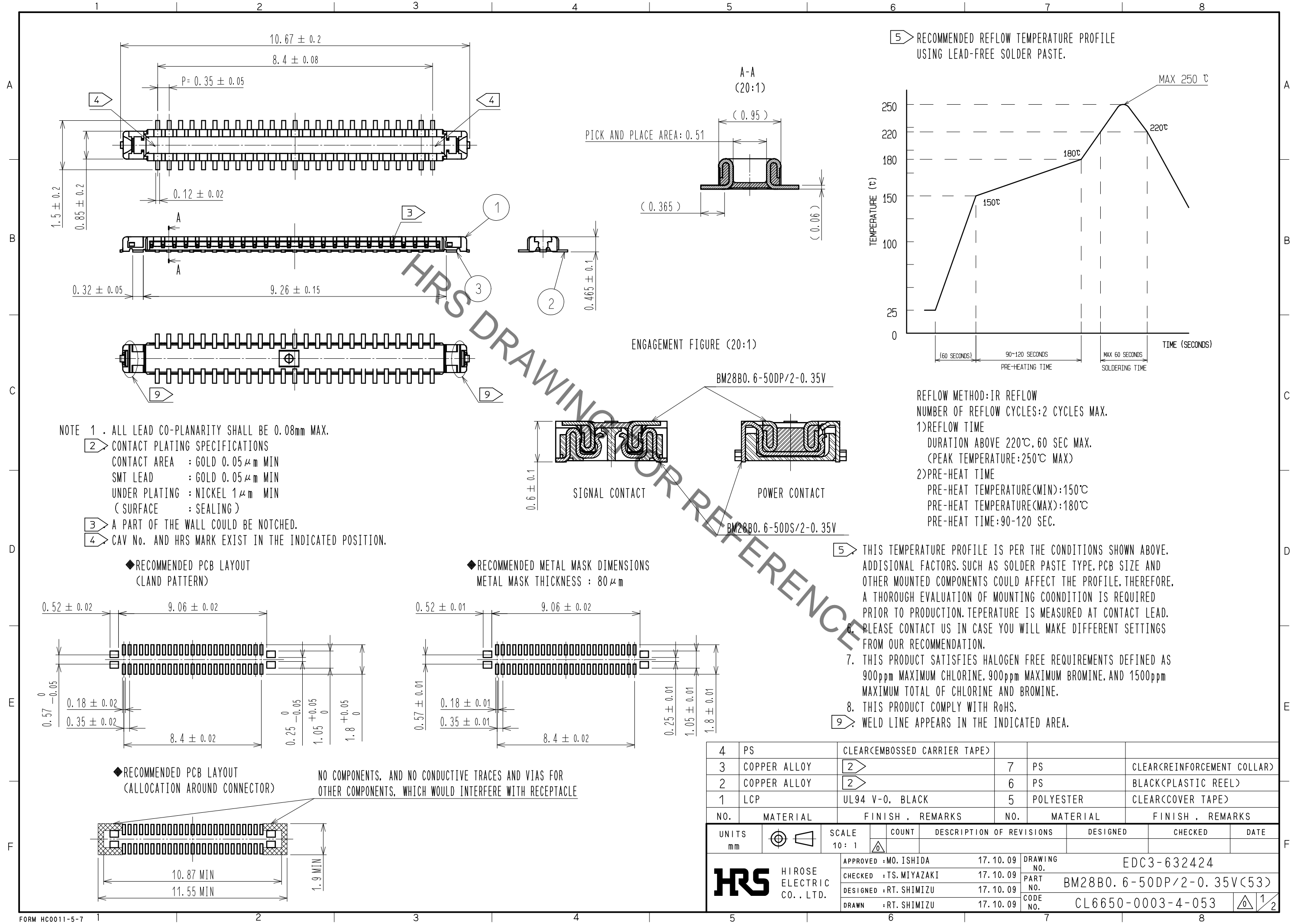

- NOTE 1 . ALL LEAD CO-PLANARITY SHALL BE 0.08mm MAX.  
 2 CONTACT PLATING SPECIFICATIONS  
 CONTACT AREA : GOLD 0.05 μm MIN  
 SMT LEAD : GOLD 0.05 μm MIN  
 UNDER PLATING : NICKEL 1 μm MIN  
 ( SURFACE : SEALING )  
 3 A PART OF THE WALL COULD BE NOTCHED.  
 4 CAV No. AND HRS MARK EXIST IN THE INDICATED POSITION.

◆RECOMMENDED PCB LAYOUT (LAND PATTERN)

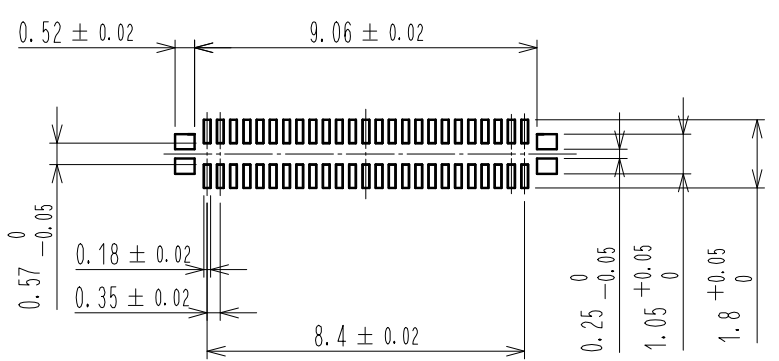

◆RECOMMENDED METAL MASK DIMENSIONS  
 METAL MASK THICKNESS : 80 μm

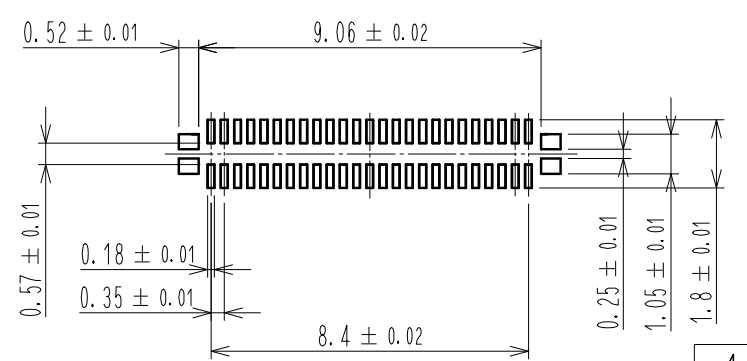

◆RECOMMENDED PCB LAYOUT (ALLOCATION AROUND CONNECTOR)

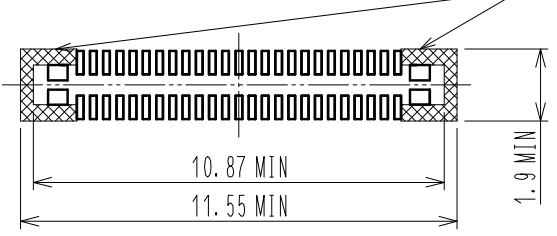

NO COMPONENTS, AND NO CONDUCTIVE TRACES AND VIAS FOR OTHER COMPONENTS, WHICH WOULD INTERFERE WITH RECEPTACLE

4	PS	CLEAR(EMBOSSED CARRIER TAPE)			
3	COPPER ALLOY	2	7	PS	CLEAR(REINFORCEMENT COLLAR)
2	COPPER ALLOY	2	6	PS	BLACK(PLASTIC REEL)
1	LCP	UL94 V-0, BLACK	5	POLYESTER	CLEAR(COVER TAPE)
NO.	MATERIAL	FINISH . REMARKS	NO.	MATERIAL	FINISH . REMARKS

UNITS	SCALE	COUNT	DESCRIPTION OF REVISIONS	DESIGNED	CHECKED	DATE
mm	10:1	△				
APPROVED : MO. ISHIDA		17.10.09	DRAWING NO. EDC3-632424			
CHECKED : TS. MIYAZAKI		17.10.09	PART NO. BM28B0. 6-50DP/2-0.35V(53)			
DESIGNED : RT. SHIMIZU		17.10.09	CODE NO. CL6650-0003-4-053			
DRAWN : RT. SHIMIZU		17.10.09	1/2			

Aug.1.2020 Copyright 2020 HIROSE ELECTRIC CO., LTD. All Rights Reserved.  
 In case of consideration for using Automotive equipment / device which demand high reliability, kindly contact our sales window correspondents.

# EMBOSED CARRIER TAPE PACKAGING (5:1)

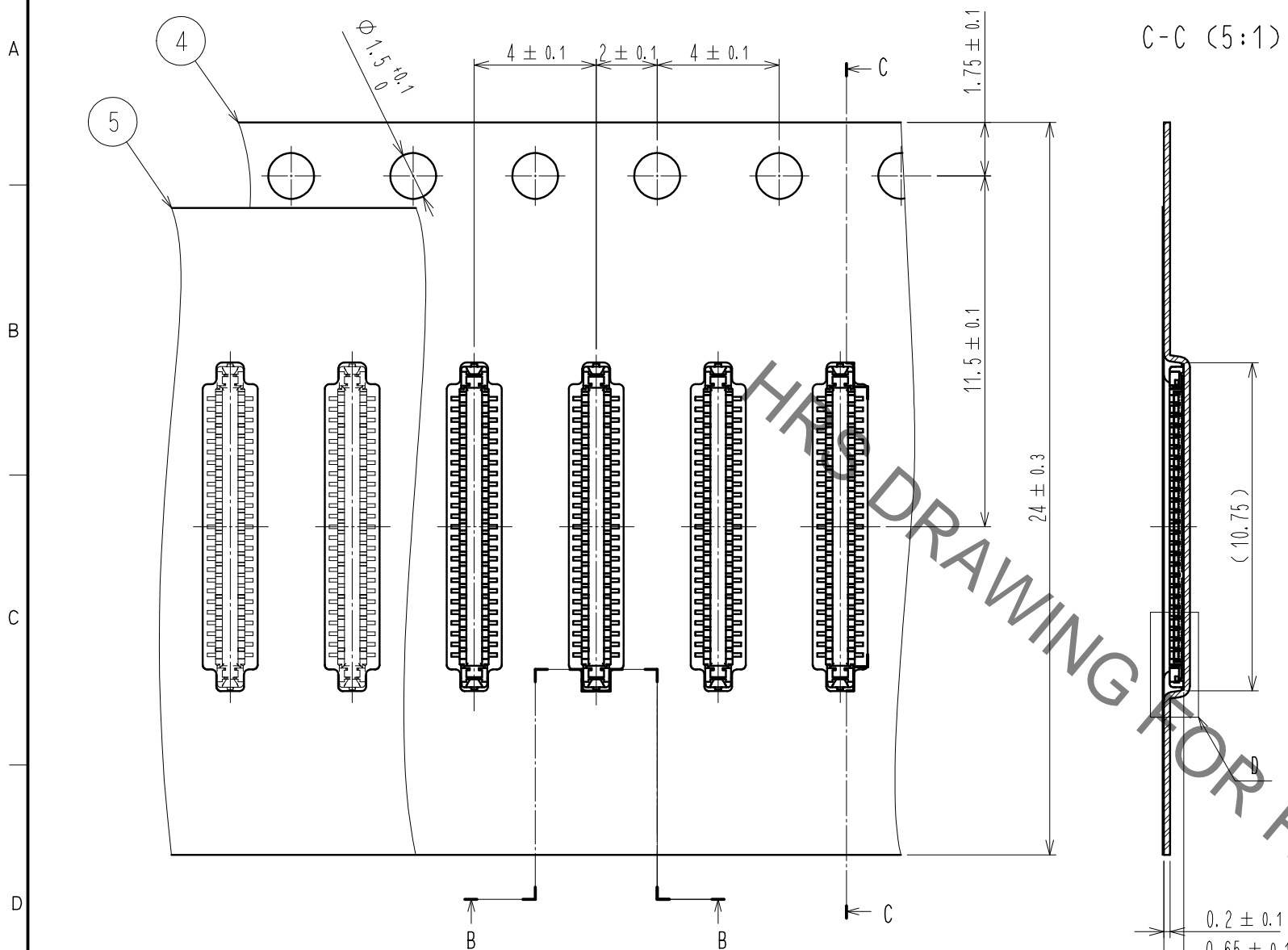

C-C (5:1)

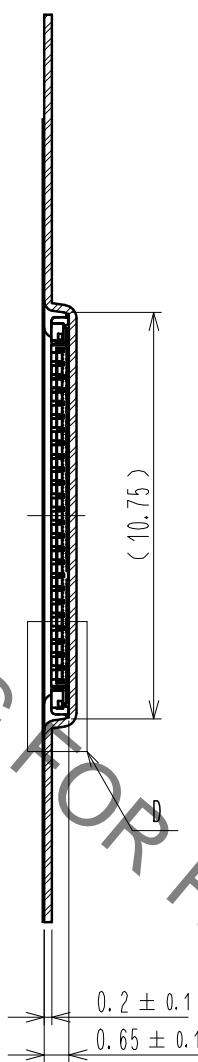

# STYLE AND DIMENSION OF REEL (FREE)

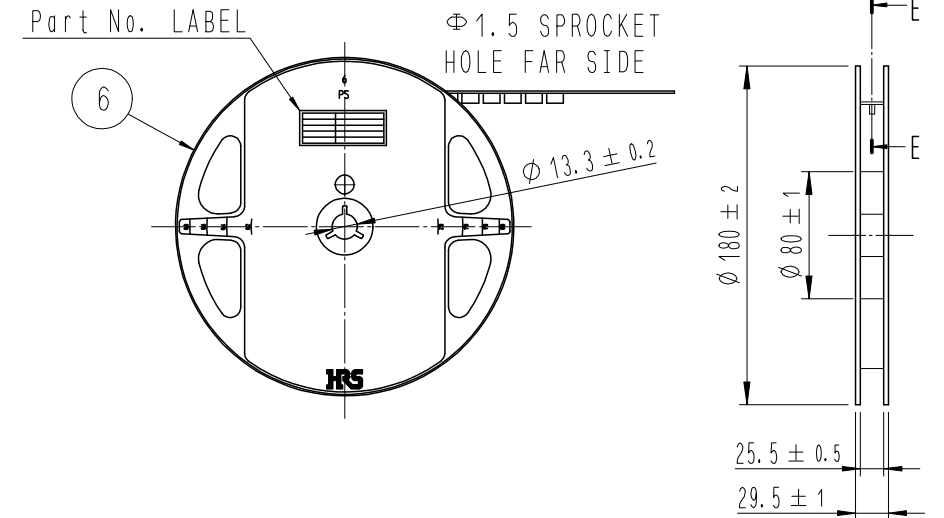

E-E (FREE)

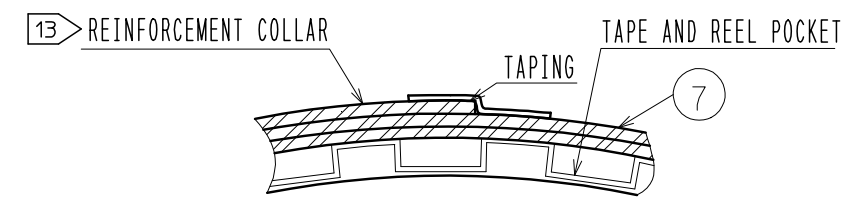

B-B (5:1)

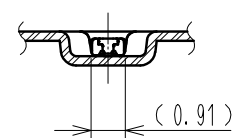

DIRECTION OF UNREELING

D (10:1)

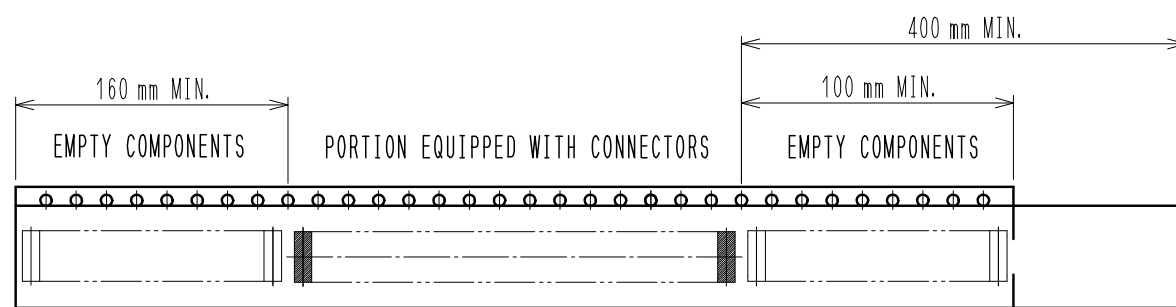
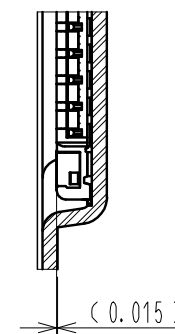

12 TAPING (FREE)

## DETAIL OF PART NO. LABEL

製造年月日	** ** *	DATA OF MANUFACTURED
製品コード	CL6650-****-**	CODE NO.
製品名	BM28B0.6-**	PART NO.
数量	1,000	QUANTITY
納入者	ヒロセ電機(株)	SUPPLIER

- 10. PER REEL 1,000 CONNECTORS.
- 11. THE DIMENSIONS IN PARENTHESES ARE FOR REFERENCE.
- 12 REFER TO JIS C 0806. IEC 60286-3(PACKAGING OF COMPONENTS FOR AUTOMATIC HANDLING)
- 13 AFTER PACKAGING. ROLL 2 METERS OF THE REINFORCEMENT COLLAR TO OUTER CIRCUMFERENCE OF TAPE AND REEL POCKET. AND TAPE DOWN AT THE END THE COLLAR.

<b>HRS</b>	DRAWING NO.	EDC3-632424
	PART NO.	BM28B0.6-50DP/2-0.35V(53)
	CODE NO.	CL6650-0003-4-053
		$\triangle$ 2/2