

REVISIONS			
REV	DESCRIPTION, ECN, EAR NO.	DATE	APPD
A	PROPOSAL DRAWING	NOV30/18	S.M.
B	CURRENT RATING CHANGE	JAN22/19	S.M.
C	UPDATE PACKAGING INFORMATION	MAR11/19	S.M.

WIRE SIZE	MAX INSULATION	DIM 'A'	DIM 'B'	DIM 'C'	DIM 'D'	DIM 'E'	DIM 'F'
18 - 22	1.5	2.29	2.54	0.76	1.91	2.08	0.64

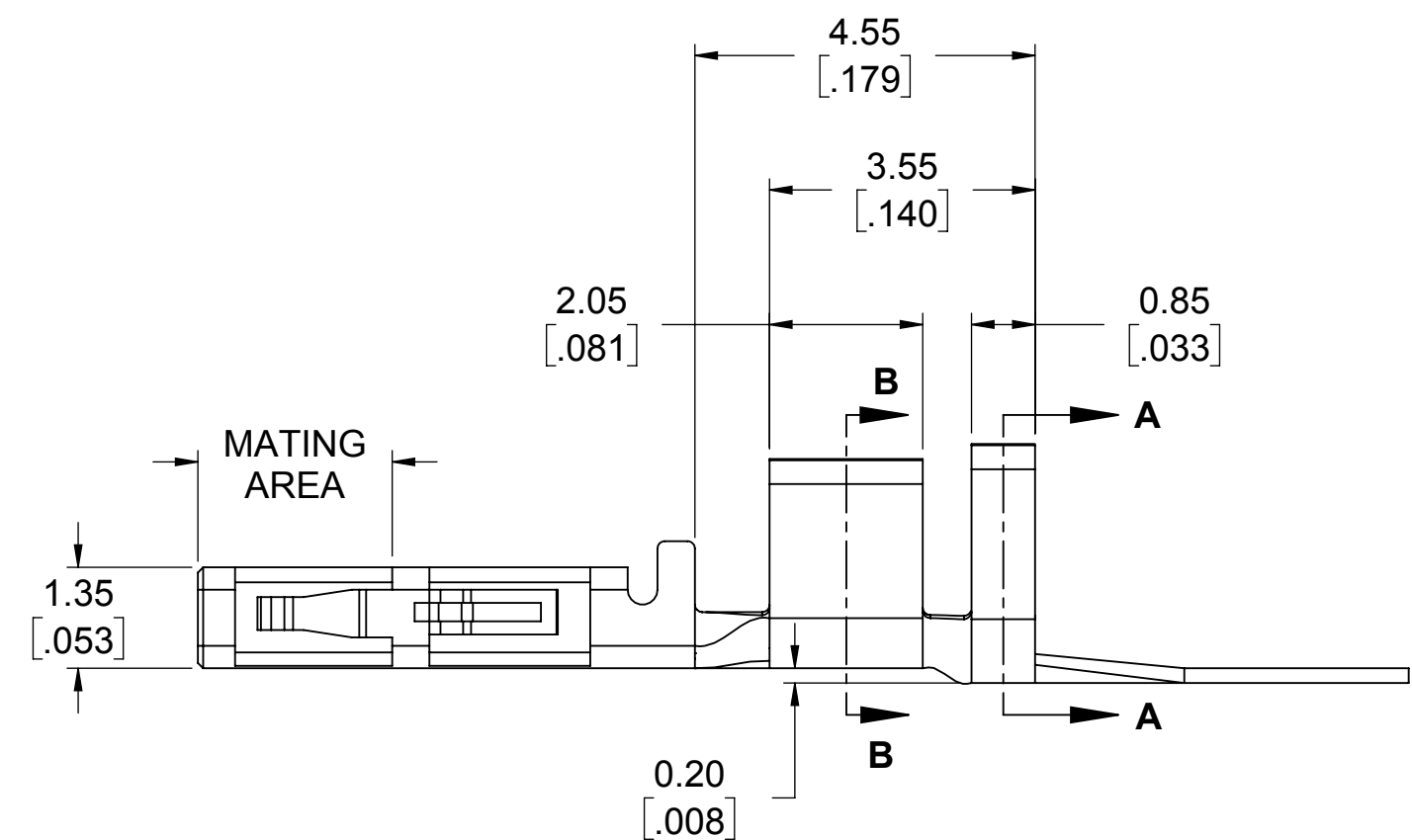
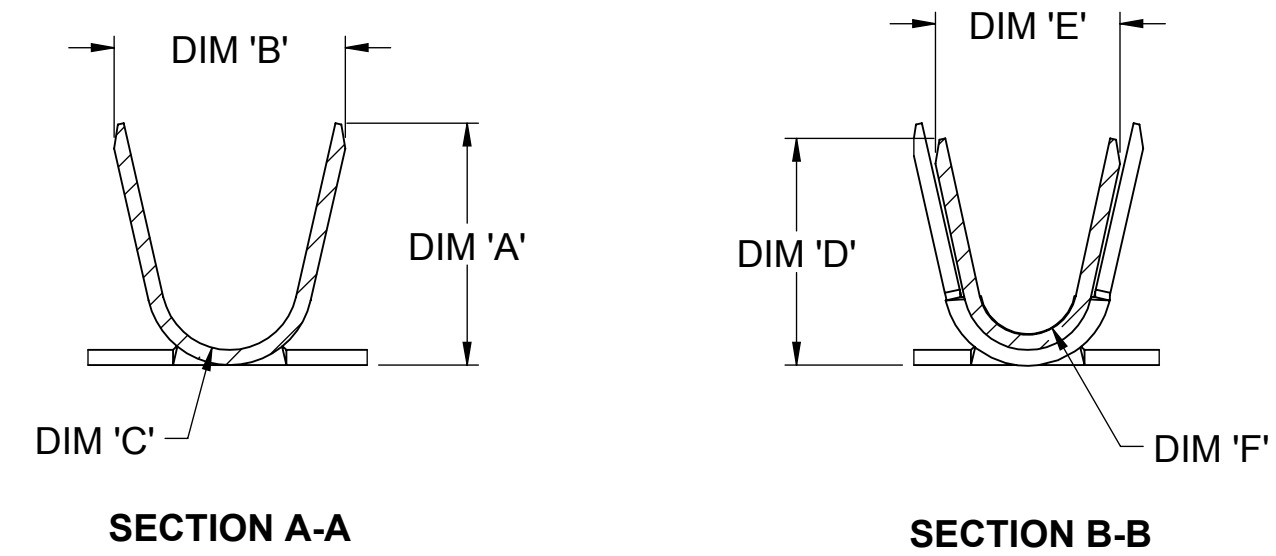
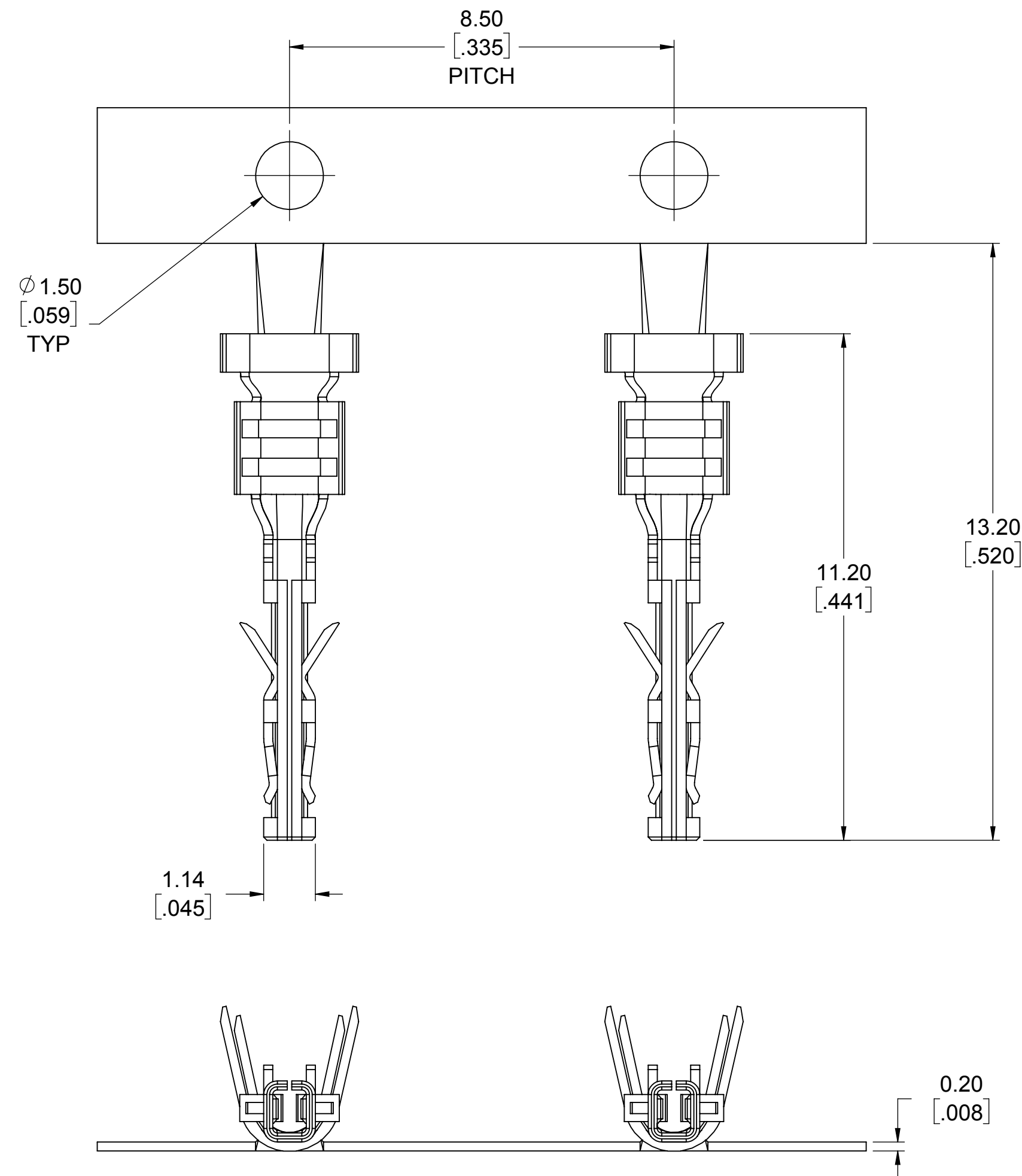

PART NUMBER: FLH - SC136 - XXX

SERIES
FLH

CONTACT TYPE
SC = SOCKET CONTACT
3 = AWG #18 - AWG #22

CONTACT FINISH
T01 = 100µ" TIN
G15 = 15µ" GOLD
G30 = 30µ" GOLD

NOTES:

- MATERIALS: ALL MATERIALS ARE RoHS COMPLIANT PER EU DIRECTIVE 2011/65/EU & AMENDMENTS
 - CONTACTS: PHOSPHOR BRONZE PLATED WITH NICKEL UNDER PLATE ALL OVER. MATING AREA PLATED WITH MATTE TIN OR GOLD AS DEFINED BY THE PART NUMBER SELECTED.
- ELECTRICAL CHARACTERISTICS
 - CURRENT RATING: 8A (18 AWG) OR 5A (20 AWG) OR 3A (22 AWG) PER CONTACT WHEN USING 3 CONTACTS
 - OPERATING TEMPERATURE: -40°C TO +105°C
- CONTACT DESIGNED FOR SOCKET HOUSING P/N: FLH-SX1-00



AMPHENOL PART NUMBER: FLH-SC136-XXX

UNLESS SPECIFIED OTHERWISE	DRAWN	B.COPPING	NOV30/18
PRIMARY UNITS MILLIMETERS	CHECKED	S.MUGAN	NOV30/18
SECONDARY INCHES	M.E. APP'D		
REFERENCE IN PARENTHESES	Q.A. APP'D		
GENERAL TOLERANCES	DWG APPR.		
1 DECIMAL PLACE	ENG. REL. NO.		
2 DECIMAL PLACES ±0.20	REF.		
3 DECIMAL PLACES	THIRD ANGLE PROJECTION	DO NOT SCALE DRAWING	
ANGULAR DEGREES			

Amphenol Canada Corp.
Commercial Products

**FLH SERIES, 2.5mm PITCH
SOCKET CONTACT, CRIMP
TERMINATION, RoHS COMPLIANT**

DWG. NO. **P-FLH-SC136-XXX** REV **C**

CODE ID NO. 03554 DWG SIZE: X SCALE: 10:1 SHEET 1 OF 2

REVISIONS			
REV	DESCRIPTION, ECN, EAR NO.	DATE	APP'D
A	PROPOSAL DRAWING	NOV30/18	S.M.
B	CURRENT RATING CHANGE	JAN22/19	S.M.
C	UPDATE PACKAGING INFORMATION	MAR11/19	S.M.

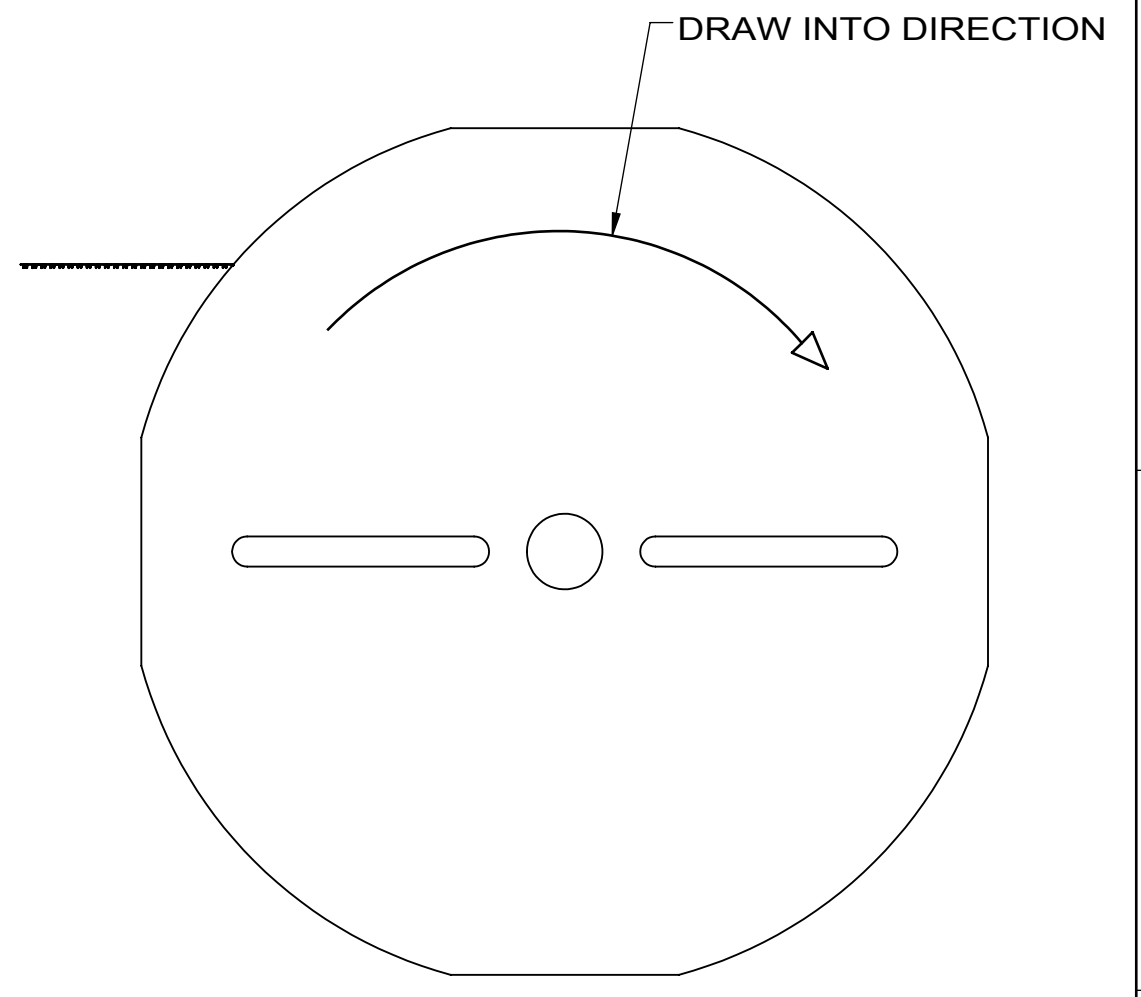
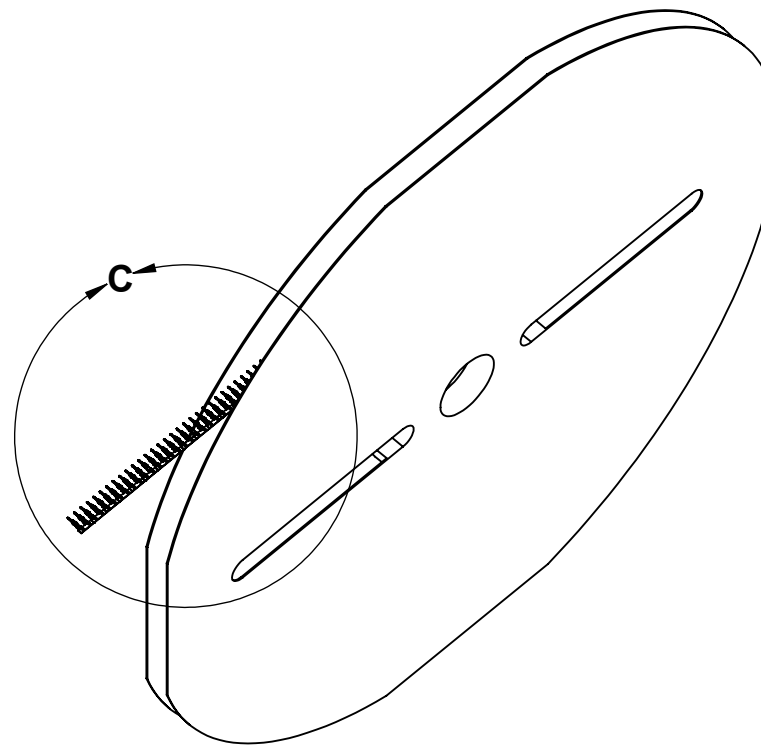
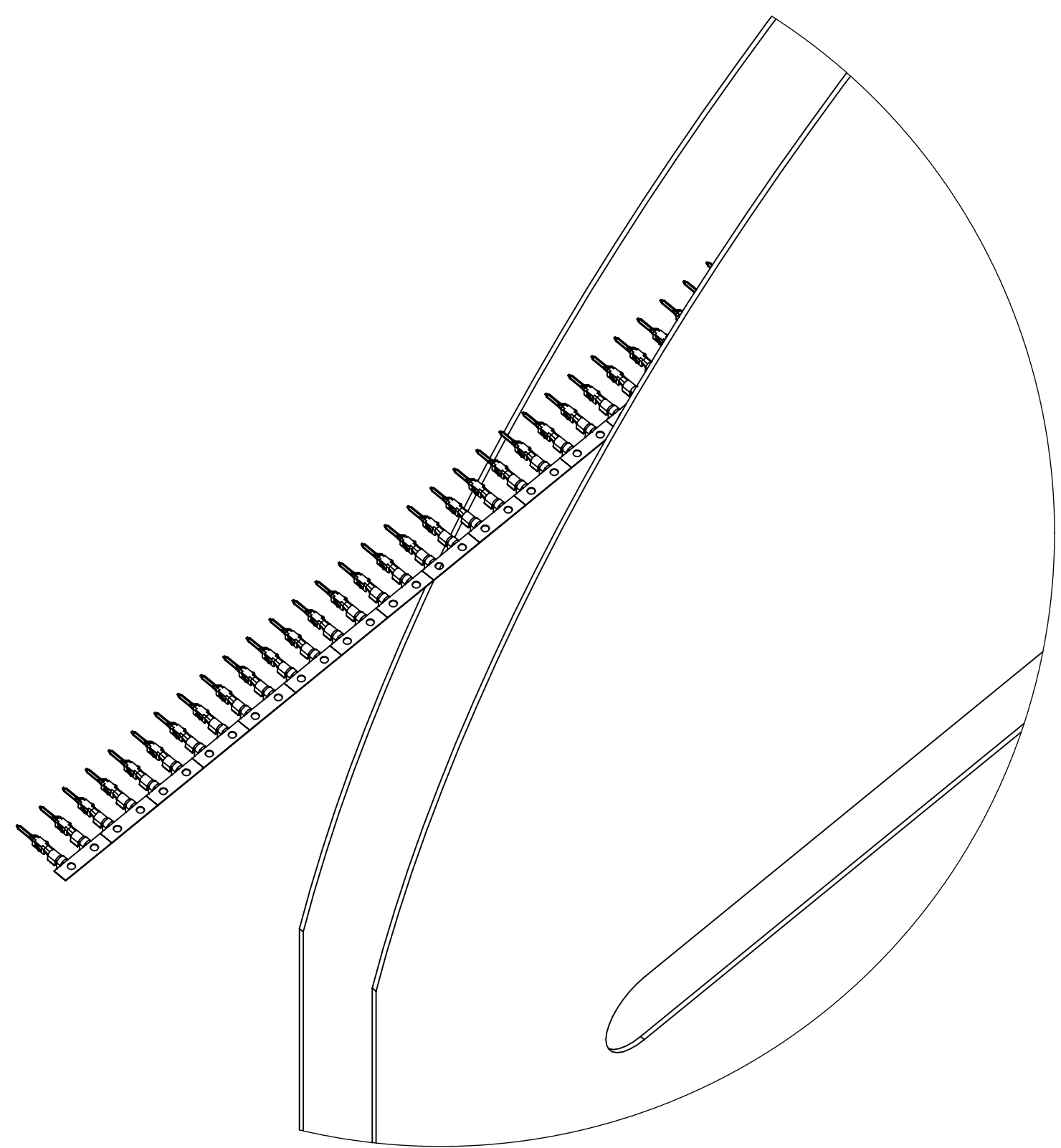

**DETAIL C
SCALE 1 : 1**

PACKAGING: FLH-SC136-XXX 6000 PCS PER REEL.



UNLESS SPECIFIED OTHERWISE	DRAWN	B.COPPING	NOV30/18
PRIMARY UNITS	MILLIMETERS	CHECKED	S.MUGAN
SECONDARY	INCHES	M.E. APP'D	
REFERENCE IN PARENTHESES		Q.A. APP'D	
GENERAL TOLERANCES		DWG APPR.	
1 DECIMAL PLACE		ENG. REL. NO.	
2 DECIMAL PLACES	±0.20	REF.	
3 DECIMAL PLACES		THIRD ANGLE PROJECTION	
ANGULAR DEGREES		DO NOT SCALE DRAWING	

Amphenol Canada Corp.
Commercial Products

**FLH SERIES, 2.5mm PITCH
SOCKET CONTACT, CRIMP
TERMINATION, RoHS COMPLIANT**

DWG. NO. **P-FLH-SC136-XXX** REV **C**

CODE ID NO. 03554 DWG SIZE: X SCALE: 1:5 SHEET 2 OF 2