

REVISIONS			
REV	DESCRIPTION, ECN, EAR NO.	DATE	APP'D
A	PROPOSAL DRAWING	JUN13/14	L.CHAN
B	PROPOSAL DRAWING	MAR16/15	L.CHAN

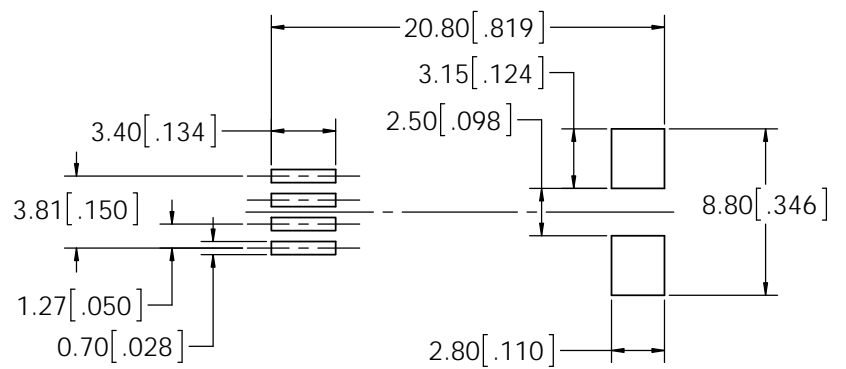
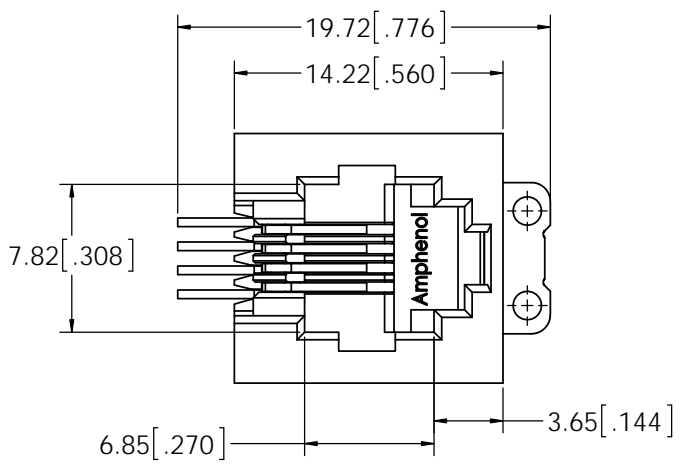

RECOMMENDED P.C.B LAYOUT
(COMPONENT SIDE OF BOARD)
TOLERANCE: ±0.05[.002]

NOTE:

- MATERIALS:**
HOUSING: HIGH TEMPERATURE THERMOPLASTIC, FLAMMABILITY RATING UL94 V-0, COLOUR: BLACK
CONTACTS: PHOSPHOR BRONZE
PLATING: SELECTIVE GOLD PLATING ON MATING SURFACES; 100u" [2.54 MICRONS] MIN. MATTE TIN ON SOLDER TAILS; 50u" [1.27 MICRONS] MIN. NICKEL UNDERPLATING OVERALL.
SOLDER BRACKET: STAINLESS STEEL
PLATING: MATTE TIN OVER ALL
- COPLANARITY SPECIFICATION:**
THE MAX GAP BETWEEN ALL TERMINAL TAILS & SOLDER BRACKET IS 0.10[.004]

AMPHENOL PART NUMBER: RJE23-144-0X13-T

- GOLD PLATING OPTION**
- 1= 6u" [0.15 MICRONS] GOLD PLATING
 - 2= 15u" [0.38 MICRONS] GOLD PLATING
 - 3= 30u" [0.76 MICRONS] GOLD PLATING
 - 4= 50u" [1.27 MICRONS] GOLD PLATING

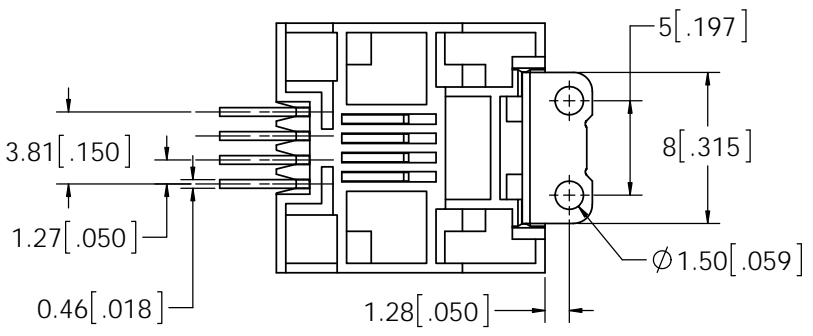
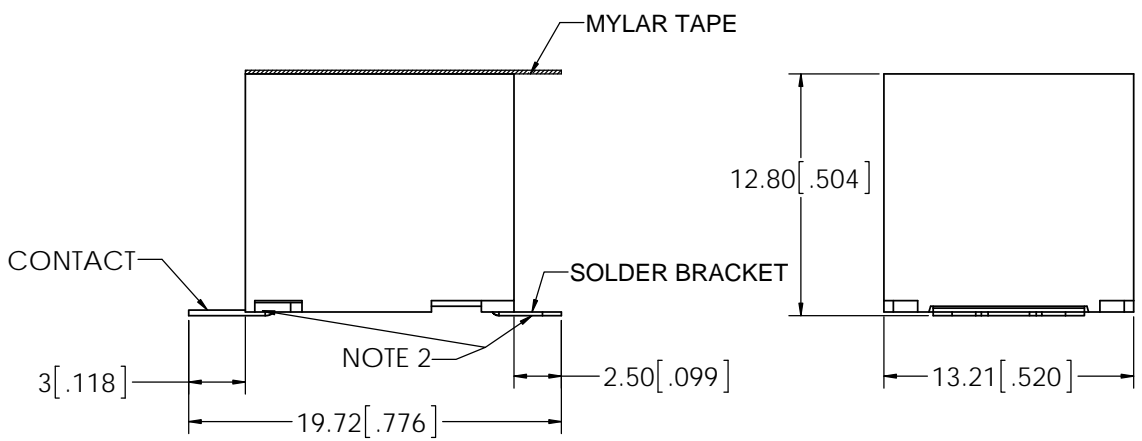

UNLESS SPECIFIED OTHERWISE	DRAWN	J.FENG	JUN13/14
PRIMARY UNITS	MILLIMETERS	CHECKED	L.CHAN
SECONDARY	INCHES	M.E. APP'D	
REFERENCE IN PARENTHESES		Q.A. APP'D	
GENERAL TOLERANCES IN MM	DWG APPR.	L.CHAN	JUN13/14
1 DECIMAL PLACE	ENG. REL. NO.		
2 DECIMAL PLACES	REF.		
3 DECIMAL PLACES	THIRD ANGLE PROJECTION		
ANGULAR DEGREES	DO NOT SCALE DRAWING		

Amphenol Canada Corp.

TOP ENTRY MODULAR JACK, SURFACE MOUNT, 4 POSITIONS, 4 CONTACTS, WITH MYLAR TAPE, T&R PACKAGE -RoHS COMPLIANT

DWG. NO. **P-RJE23-144-0X13-T** REV **B**

CODE ID NO. 03554 DWG SIZE: C SCALE: 5:1 SHEET 1 OF 2

REVISIONS			
REV	DESCRIPTION, ECN, EAR NO.	DATE	APP'D
A	PROPOSAL DRAWING	JUN13/14	L.CHAN
B	PROPOSAL DRAWING	MAR16/15	L.CHAN

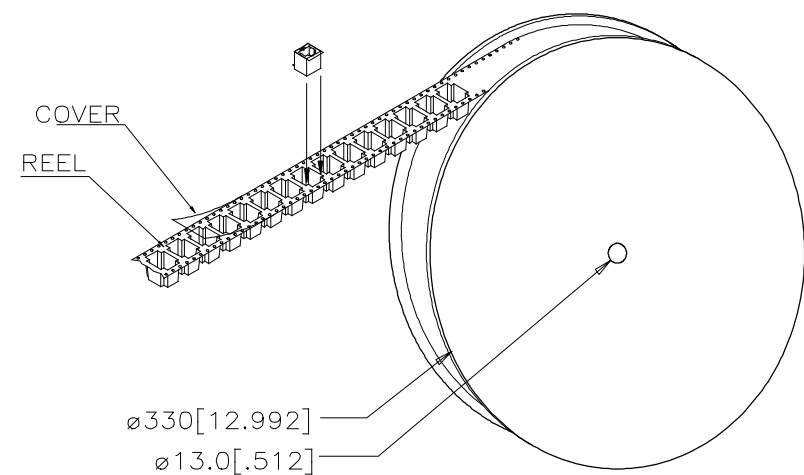
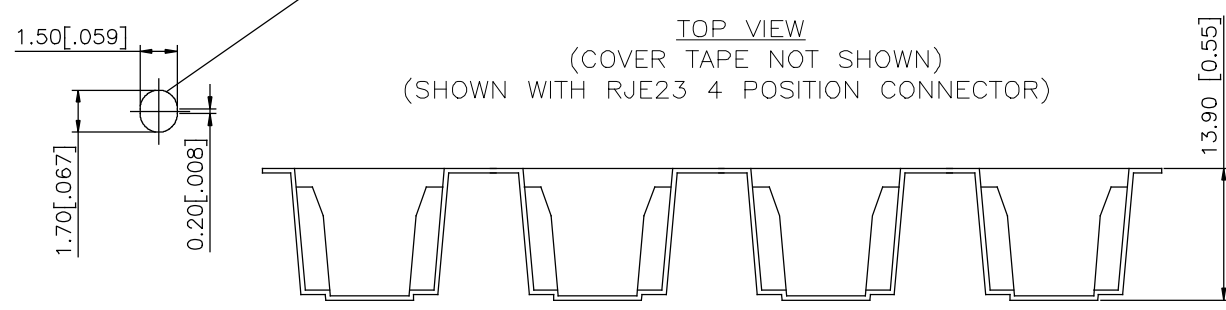
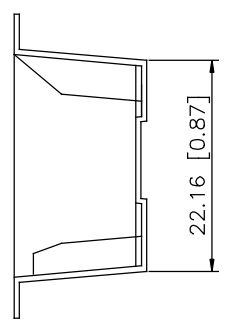
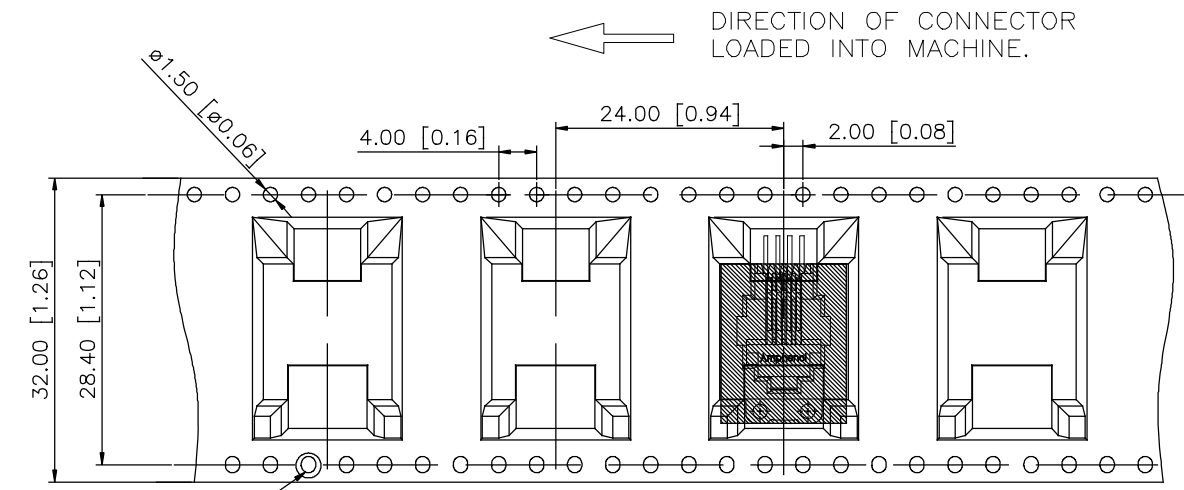

PACKAGING NOTES:

- ONE REEL SHOULD HOLD 200 CONNECTORS.
- 5 EMPTY CAVITIES FOR CARRIER TAPE LEADER & 7 EMPTY CAVITIES FOR CARRIER TAPE TRAILER.
- A FULLY LOADED CARTON SHOULD CONTAIN 7 REELS(1400 PCS) OF CONNECTORS.

UNLESS SPECIFIED OTHERWISE	DRAWN Justin Feng	JUN13/14	Amphenol Canada Corp. www.amphenolcanada.com
PRIMARY UNITS MILLIMETERS	CHECKED L.Chan	JUN13/14	
SECONDARY INCHES	M.E. APP'D		TOP ENTRY MODULAR JACK, SURFACE MOUNT, 4 POSITIONS, 4 CONTACTS, WITH MYLAR TAPE, T&R PACKAGE—ROHS COMPLIANT
REFERENCE IN PARENTHESES	Q.A. APP'D		
GENERAL TOLERANCES FOR MM	DWG APP'D		DWG NO. P-RJE23-144-0X13-T
1 DECIMAL PLACE ±0.38	ENG. REL. NO.		
2 DECIMAL PLACE ±0.25	REF.		REV B
3 DECIMAL PLACE ±0.13	THIRD ANGLE PROJECTION	DO NOT SCALE DRAWING	CODE ID NO. 03554
ANGULAR DEGREES ±1.5°			DWG SIZE: C
			SCALE: N/A
			SHEET 2 OF 2

THIS DOCUMENT CONTAINS PROPRIETARY INFORMATION AND SUCH INFORMATION MAY NOT BE DISCLOSED TO OTHERS FOR ANY PURPOSE OR USED FOR MANUFACTURING PURPOSES WITHOUT WRITTEN PERMISSION FROM AMPHENOL CANADA CORP.