

NOTES:

- CONTACT RETENTION FORCE: 2 lbs
- MAX ALLOWABLE BOW: .006 [.15] IN/IN
- "END WALLS" AFTER CUTTING SHOULD BE .015±.001 [.38±.03].
- WHEN FILLING THE ASSEMBLY, ALL CONTACTS MUST BE FACING THE SAME DIRECTION.
- (C) REPRESENTS CRITICAL DIMENSION.
- CUT FLASH: .015 [.38] MAX WITH NO FLASH ALLOW IN HOLES.
- .003 [.08] MAX TERMINAL BURR.

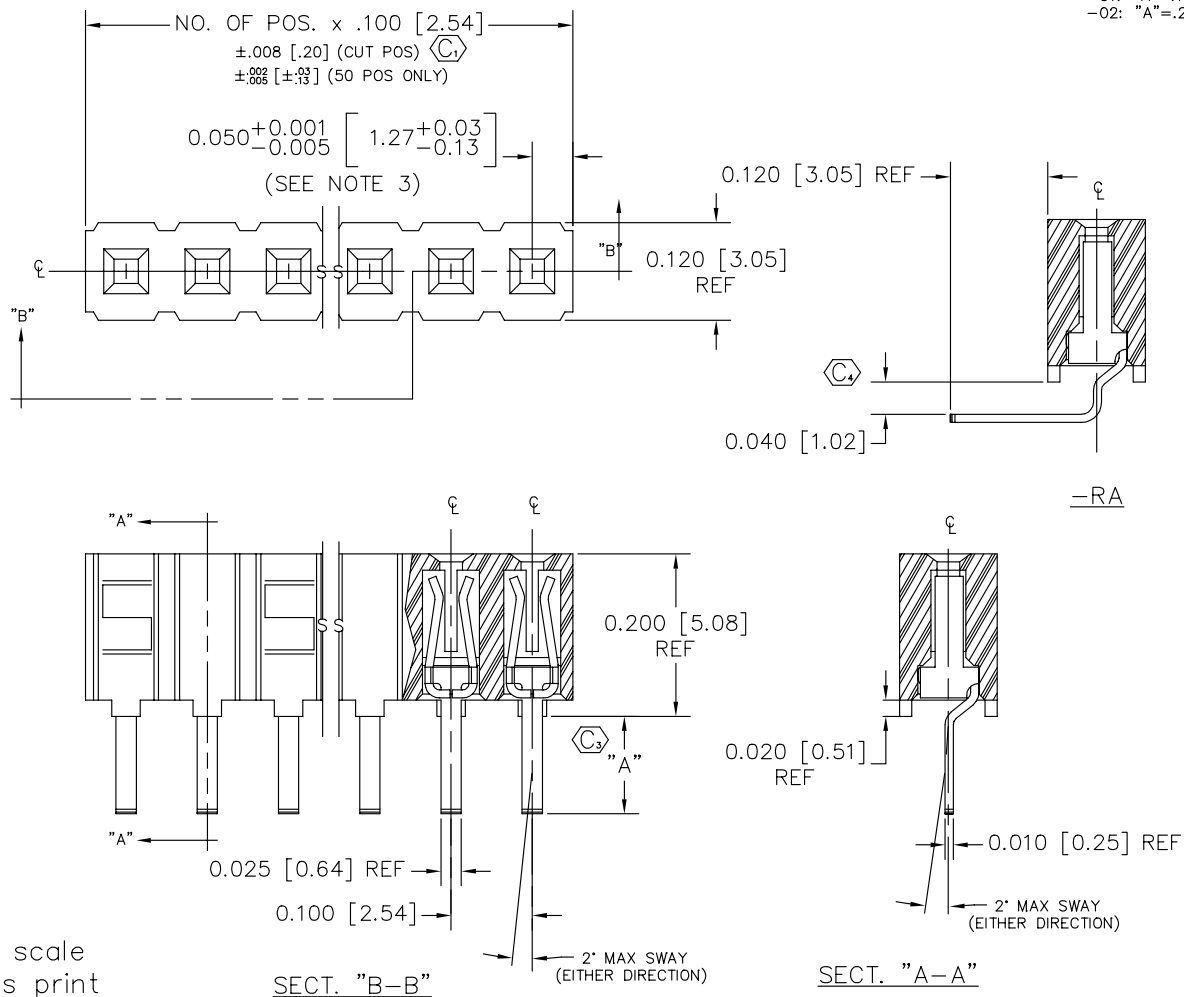

CES-1XX-XX-X-X-XX

POSITION SPECIFICATIONS

-01 THRU -50

CONTACT LEAD STYLE

-01: "A"=.128 [3.25] (USE C-45-01-X)  
 -02: "A"=.223 [5.66] (USE C-45-02-X)

OPTIONS

-RA: RIGHT ANGLE (STYLE -02 ONLY)

ROW SPECIFICATION

-S: SINGLE (USE CES-XX-S)

PLATING SPECIFICATIONS

-T: TIN - SPECIFY -T IN CONTACT SUFFIX -X  
 -G: GOLD - SPECIFY -G IN CONTACT SUFFIX -X  
 -S: SELECTIVE - SPECIFY -S IN CONTACT SUFFIX -X  
 -F: FLASH GOLD - SPECIFY -F IN CONTACT SUFFIX -X  
 (AVAILABLE IN -01 LEAD STYLE ONLY)

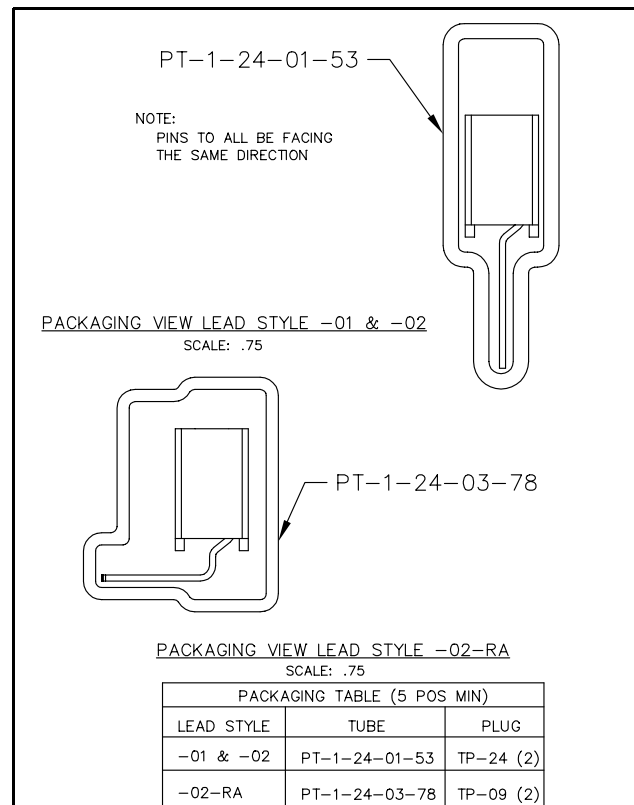

Do not scale from this print

**PROPRIETARY NOTE**  
 THIS DOCUMENT CONTAINS INFORMATION CONFIDENTIAL AND PROPRIETARY TO SAMTEC INC. AND SHALL NOT BE REPRODUCED OR TRANSMITTED TO OTHER DOCUMENTS OR DISCLOSED TO OTHERS OR USED FOR ANY PURPOSE OTHER THAN THAT FOR WHICH IT WAS OBTAINED WITHOUT THE EXPRESSED WRITTEN CONSENT OF SAMTEC INC.

MATERIAL:  
 GLASS FILLED POLYESTER  
 COLOR: BLACK

TERMINAL:  
 PHOS BRONZE

**samtec**

520 PARK EAST BLVD. NEW ALBANY, INDIANA 47150  
 PHONE (812) 944-6733 P.O. BOX 1147  
 CODE 55322

MADE BY: KOLB 12-6-89

CES-1XX-XX-X-X-XX  
 SHEET 1 OF 1