

NO.	DESCRIPTION	PART NO.	QTY	MATERIAL	DRW NO.	REMARKS
1	CONNECTOR	00 6288 0XX 000 846 +	2000	---		
2	EMBOSSED TAPE		1	POLYSTYRENE		
3	TOP COVER TAPE		1	POLYSTYRENE		
4	REEL		1	POLYSTYRENE		

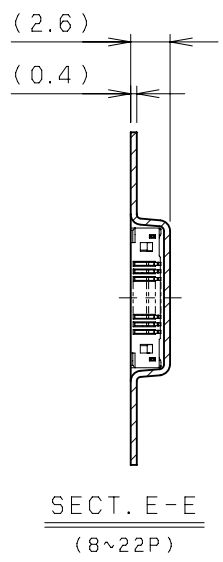

SECT. E-E  
(8~22P)

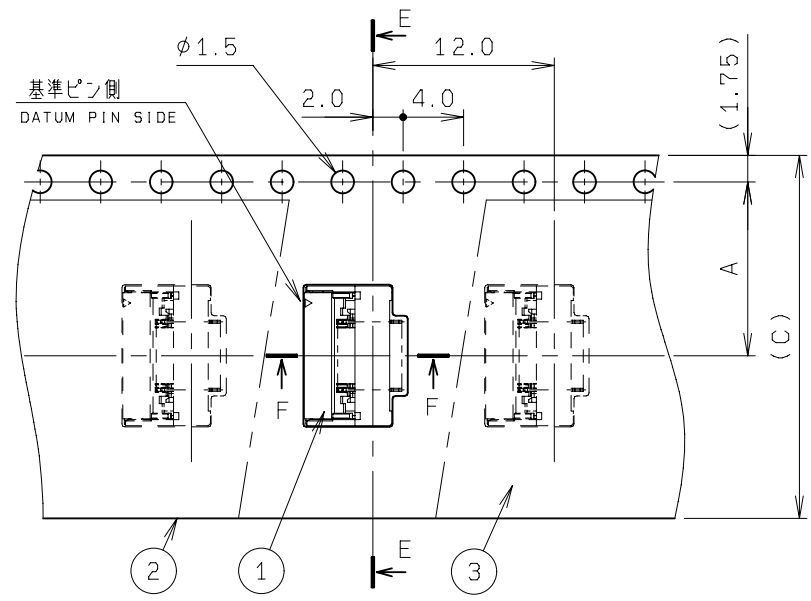
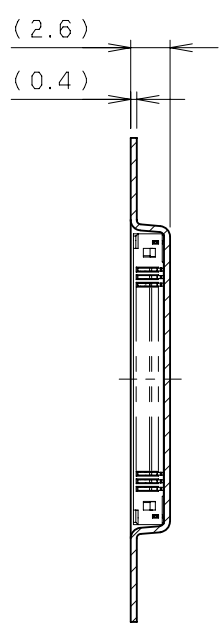
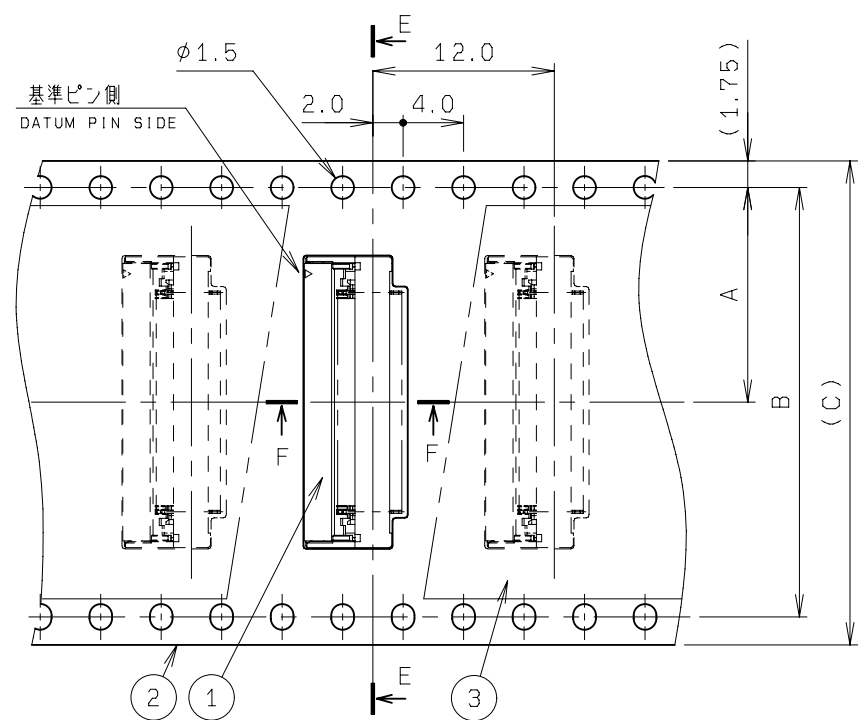

SECT. E-E  
(23~60P)

注記  
NOTE

- 梱包数量 : 2000 個/リール  
PACKING QUANTITY : 2000 ea/reel
- 納入時のリール巻き方向  
REELING DIRECTION  
IN DELIVERY

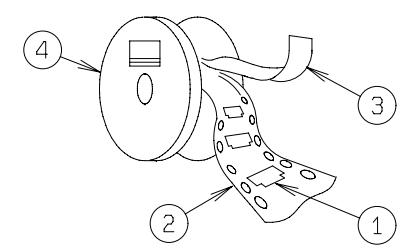

3. 引出し方向

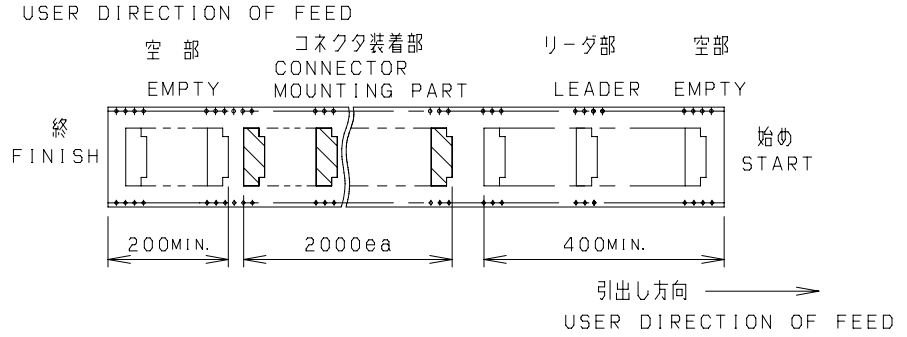

- 型番  
P/N 04 6288 0XX 000 846 +  
極数  
NO. OF POS. \_\_\_\_\_  
めっきコード  
PLATING CODE 846 + :AU

極数 NO. OF POS.	A	B	C	D
8	7.5	---	16.0	22.4
9	7.5	---	16.0	22.4
10	11.5	---	24.0	30.4
11	11.5	---	24.0	30.4
12	11.5	---	24.0	30.4
13	11.5	---	24.0	30.4
14	11.5	---	24.0	30.4
15	11.5	---	24.0	30.4
16	11.5	---	24.0	30.4
17	11.5	---	24.0	30.4
18	11.5	---	24.0	30.4
19	11.5	---	24.0	30.4
20	11.5	---	24.0	30.4

極数 NO. OF POS.	A	B	C	D
21	11.5	---	24.0	30.4
22	11.5	---	24.0	30.4
23	14.2	28.4	32.0	38.4
24	14.2	28.4	32.0	38.4
25	14.2	28.4	32.0	38.4
26	14.2	28.4	32.0	38.4
27	14.2	28.4	32.0	38.4
28	14.2	28.4	32.0	38.4
29	14.2	28.4	32.0	38.4
30	14.2	28.4	32.0	38.4
31	14.2	28.4	32.0	38.4
32	14.2	28.4	32.0	38.4
33	14.2	28.4	32.0	38.4
34	20.2	40.4	44.0	50.4
35	20.2	40.4	44.0	50.4
36	20.2	40.4	44.0	50.4
37	20.2	40.4	44.0	50.4
38	20.2	40.4	44.0	50.4
39	20.2	40.4	44.0	50.4
40	20.2	40.4	44.0	50.4
41	20.2	40.4	44.0	50.4
42	20.2	40.4	44.0	50.4
43	20.2	40.4	44.0	50.4
44	20.2	40.4	44.0	50.4
45	20.2	40.4	44.0	50.4
46	20.2	40.4	44.0	50.4
47	20.2	40.4	44.0	50.4
48	20.2	40.4	44.0	50.4
49	20.2	40.4	44.0	50.4
50	26.2	52.4	56.0	62.4
51	26.2	52.4	56.0	62.4
52	26.2	52.4	56.0	62.4
53	26.2	52.4	56.0	62.4
54	26.2	52.4	56.0	62.4
55	26.2	52.4	56.0	62.4
56	26.2	52.4	56.0	62.4
57	26.2	52.4	56.0	62.4
58	26.2	52.4	56.0	62.4
59	26.2	52.4	56.0	62.4
60	26.2	52.4	56.0	62.4

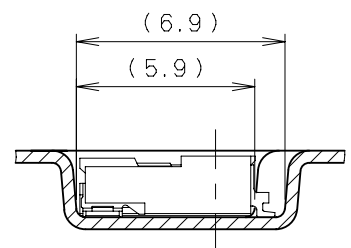

SECT. F-F (S=4/1)

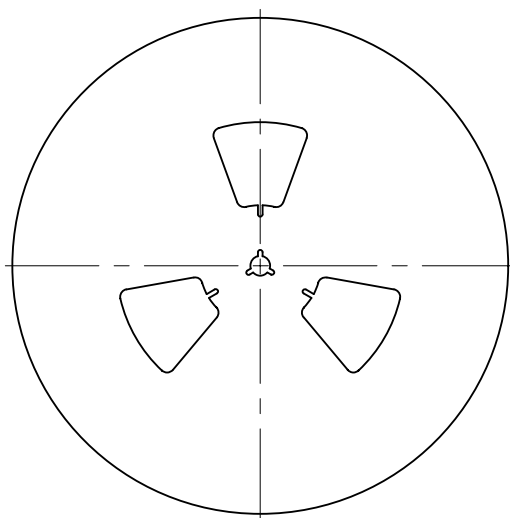

REEL DIMENSION (S=1/5)

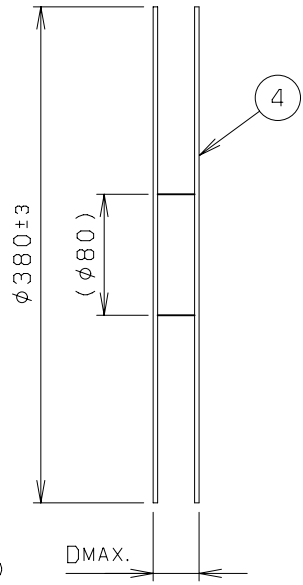

ROHS規制対応  
COMPLIANT WITH  
ROHS REGULATIONS

TOLERANCE / 一般公差 (S)		PRODUCT SPEC / 製品規格		B	DCN-431	6-02-08		
X < 10	±0.2	POLYSTYRENE (CLEAR)		A	DCN-209	3-17-08	G. SAGARA	T. SATOH
10 ≤ X < 30	±0.25	UNIT	ANGLE	O	EDN-094	2-16-08	G. SAGARA	T. SATOH
30 ≤ X	±0.3	mm	3RD	NO. EDN/DCN DATE ISSUE CHECKED APPROVED				
ANGLE / 角度	±3°	SCALE	DATE	PART NAME / 品名				
		2/1		EMBOSS TAPE ASSY FPC ASSY RA SMT 0.5mm PITCH				
DRAWN	DESIGNED	CHECKED	APPROVED	PART NO. / 型番				
G. SAGARA	G. SAGARA		T. SATOH	04 6288 0XX 000 846 +				
KYOCERA				DWG NO. / 図番		SHEET/REV		
KYOCERA ELCO CORPORATION				BJS 6288002		1/1 B		