

ISS.	AMEND	DATE
1	1st DRAWN	04/09/15
2	VIEW CORRECTED	29/09/16
3	ADD M3 VARIANT	01/06/18

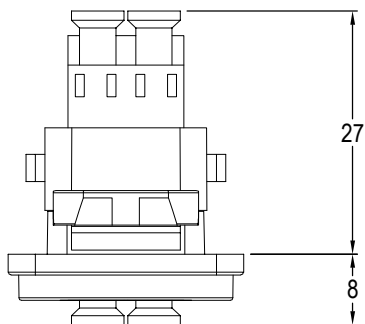
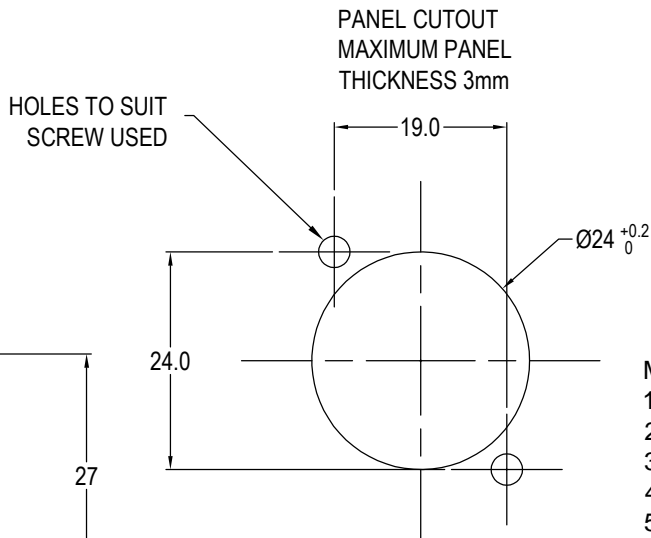
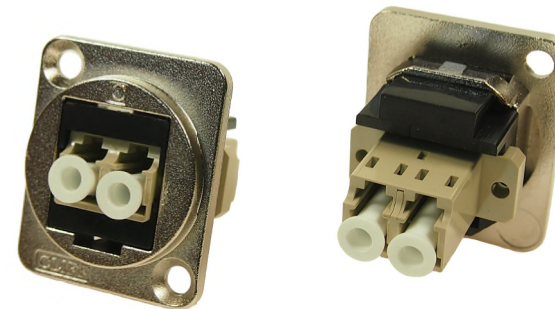

Material:

1. Coupler Body: PEI
2. Frame: Nickel plated zinc diecast
3. Sleeve: Ceramic
4. Dust Cover: PE
5. Insert: ABS/PC

Notes:

1. Insertion Loss: ≤0.3dB

VARIANTS	
PART No.	HOLE DETAILS
CP30214M	HOLE Ø3.50 x CSK 82° x Ø5.85
CP30214M3	M3 HOLES

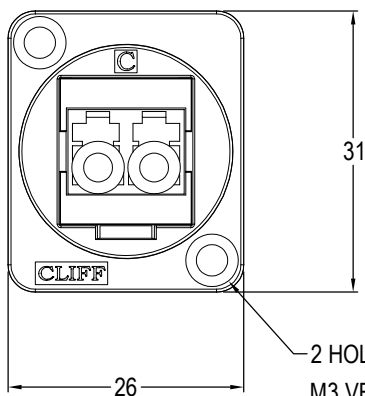

2 HOLES: Ø3.5mm CSK 82° x Ø5.85
M3 VERSION HAS M3 THREAD HOLES.

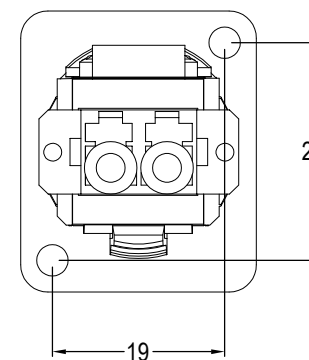
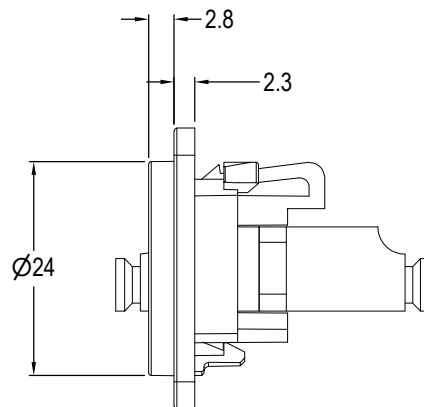

RoHS
COMPLIANT

TOLERANCE
NO DEC. PLACE ±
1 DEC. PLACE ±
2 DEC. PLACE ±
HOLE Ø ±
ANGLES ±
UNLESS
OTHERWISE STATED

DO NOT SCALE

Cliff Electronic Components Ltd.

76 Holmethorpe Avenue, Holmethorpe Industrial Estate,
Redhill, Surrey, RH1 2PF, England, UK
Tel: 01737-771375 Fax: 01737-766012 Website: www.cliffuk.co.uk

THE CONTENTS OF THIS DOCUMENT MUST NOT BE COPIED OR DISCLOSED
TO A 3rd PARTY WITHOUT WRITTEN PERMISSION OF CLIFF UK. © 2015

DIMENSIONS IN MILLIMETERS UNLESS OTHERWISE STATED. WORK TO DIMENSIONS. REMOVE ALL BURRS. IF IN DOUBT ASK.

3rd ANGLE PROJECTION:

MATERIAL: See Notes

FINISH: See Notes

DRAWN: D.P.J.

APPROVED: D.P.J.

TITLE: FT METAL LC DUPLEX MM ADAPTOR

DRWG. No. CP30214M

FORM: A4DRWGf