

This document is the property of Amphenol Corporation and is delivered on the express condition that it is not to be disclosed, reproduced or used, in whole or in part, for manufacture or sale by anyone other than Amphenol Corporation without its prior consent, & that no right is granted to disclose or to use any information in this document.

REVISIONS				
SYM	ECN	DESCRIPTION	DATE	APPROVED
2		ADD PN. of 10u" Au	2/29/12	IP

D-SUB TECHNICAL DATA

SHELL : Steel, 1.25um(50u") min nickel
 BODY : Glass filled thermoplastic.
 flame retardant to UL94 V-0 color Black
 PLATE : Glass filled thermoplastic.
 flame retardant to UL94 V-0 color Black
 CONTACTS : Brass, gold over 50u" min nickel.(According to the P/N)
 SCREWLOCK : Brass, 50u" min nickel
 REAR INSERT : Brass, 50u" min nickel
 O RING : Silicone Color: Blue
 EPOXY: Color: Black
 ELECTRICAL : Voltage rating: 300 V/RMS at 50Hz
 Current rating : 5A
 Insulation resistance >5000 MOhms
 Contact resistance 20 mOhms max.
 MARKING : Amphenol logo
 Commercial code
 Manufacturing date(YYWW)



NOTE : Screw L=4.7 For Panel Thickness
 Under X=1.2mm
 Screw L=5.7 For Panel Thickness
 Between X=1.2~2.0mm

PRODUCT CODE

L 17ED XX S 0 X

L: RoHS Compliance

17ED:
standard density series

Number of contacts
Standard density:
09, 15, 25, 37

Contact plating:
0: gold flash
1: 0.38um(15u")
2: 0.76um(30u")
4: 0.25um(10u")

Termination:
0: Solder cup

Contact type
S: Socket

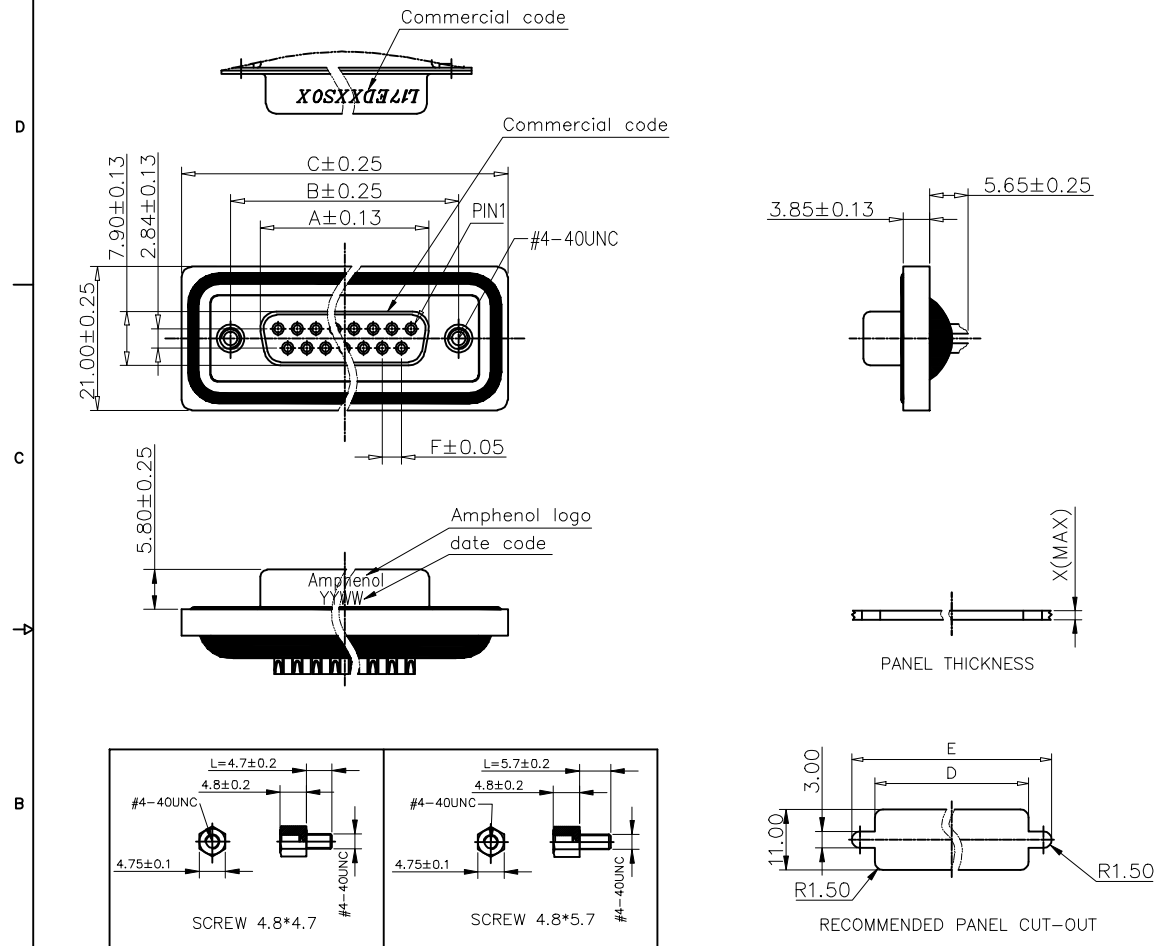

Customer drawing

POSITION	A	B	C	D	E	F(PITCH)
9	16.24	24.99	39.40	20.00	28.20	2.77
15	24.60	33.32	47.70	28.00	36.50	2.77
25	38.38	47.04	64.50	41.50	51.00	2.77
37	54.76	63.50	80.78	57.80	67.30	2.77

UNLESS OTHERWISE SPECIFIED TOLERANCES	APPROVAL		DATE
	U.S.	METRIC	DRAWN
.X +/- 0.50			XS.Cuo
.XX +/- 0.30			2/29/12
.XXX +/- 0.20			CHECKED
FRACTIONS +/-			2/29/12
ANGLES +/- 2'			CHECKED
FOR MATERIALS AND FINISHES SEE NOTES	DRAWING FILE :		
REMOVE SHARP EDGES	ANGLE OF PROJECTION		
DIMENSIONS	U.S. INCHES		
U.S.	MM		

Amphenol		Amphenol East Asia Limited
TITLE		
D-sub Waterproof, ED series female Solder cup type		REV. 2
SIZE	DRAWING NO.	
A4	C L17EDXXS0X	
SCALE	NONE	SHEET 1 OF 1