



PART NO.

M90-3106F14S-6P

REVISIONS

ECN #	REV	DESCRIPTION	DRAWN	DATE	CHECKD	DATE	APPRVD	DATE
-	A	RELEASED	Shalini	30/03/09	Veena	30/03/09	Farnell	13/04/09

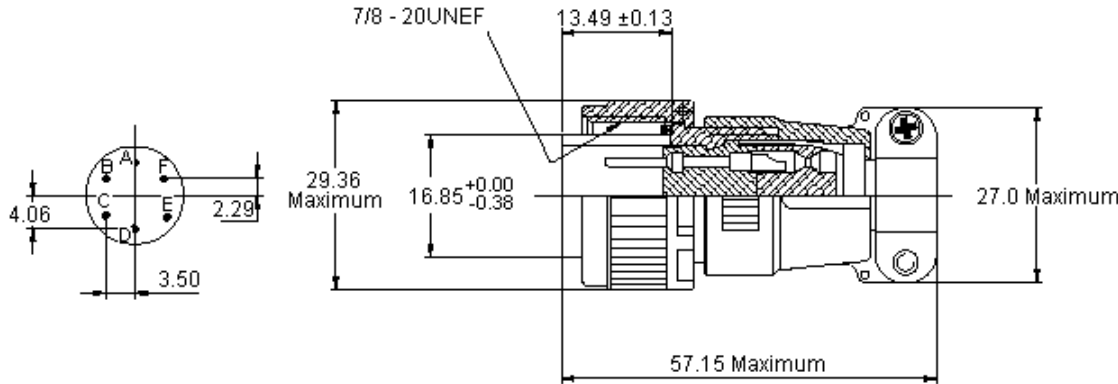

Dimensions : Millimetres

Specifications:

Material and Finishes:

- Shell : Aluminium alloy, zinc plated with black chromate coating.
- Insulator : Polychloroprene.
- Grommet : Polychloroprene.
- Contact : Copper alloy, silver plated.

Mechanical Features

- Coupling : Threaded.
- Polarisation : Single key/keyway.
- Contact type : Solder.
- Contact arrangement : 6 contacts.
- Durability : 500 cycles, mate and unmate.

Electric Data

- Current rating : 13 amperes.
- Voltage rating : Working 200V ac, 250V dc.
- Minimum insulation resistance : 5000MΩ.

Environmental Data

- Operating temperature : -55°C to +125°C.
- Vibration : 10 to 500Hz (10G), per MIL-STD-1344, Method 2005.
- Salt spray : 48 hours salt solution 5%, per MIL-1344, Method 1001.
- Humidity : Relative humidity 95 ±3%, 71°C ±2°C, 14 days.

Part Number Table

Description	Part Number
Plug, Free, 6 Way	M90-3106F14S-6P

<http://www.farnell.com>

<http://www.newark.com>

<http://www.cpc.co.uk>

This data sheet and its contents (the "Information") belong to the Premier Farnell Group (the "Group") or are licensed to it. No licence is granted for the use of it other than for information purposes in connection with the products to which it relates. No licence of any intellectual property rights is granted. The Information is subject to change without notice and replaces all data sheets previously supplied. The Information supplied is believed to be accurate but the Group assumes no responsibility for its accuracy or completeness, any error in or omission from it or for any use made of it. Users of this data sheet should check for themselves the Information and the suitability of the products for their purpose and not make any assumptions based on information included or omitted. Liability for loss or damage resulting from any reliance on the Information or use of it (including liability resulting from negligence or where the Group was aware of the possibility of such loss or damage arising) is excluded. This will not operate to limit or restrict the Group's liability for death or personal injury resulting from its negligence. SPC MULTICOMP is the registered trademark of the Group. © Premier Farnell plc 2009.

**TOLERANCES:**  
**UNLESS OTHERWISE SPECIFIED, DIMENSIONS ARE FOR REFERENCE PURPOSES ONLY.**

<b>DRAWN BY:</b>	<b>DATE:</b>
Shalini	31/03/09
<b>CHECKED BY:</b>	<b>DATE:</b>
Veena	30/03/09
<b>APPROVED BY:</b>	<b>DATE:</b>
Farnell	13/04/09

DRAWING TITLE:

Plug, Free - 6 Way

SIZE <b>A</b>	DWG NO. <b>M10002015</b>	ELECTRONIC FILE <b>88732_DWG</b>	REV <b>A</b>
SCALE: NTS	U.O.M.: mm	SHEET: 1 OF 1	