

BILL OF MATERIALS				
DET.	QTY.	DESCRIPTION	MATERIAL	PLATING
1	1	BUSHING	BRASS	NICKEL
2	1	NUT	BRASS	NICKEL

REVISIONS				
SYM	DESCRIPTION	REVISED BY	DATE	APPR
A	REDRAWN IN CAD FROM "NO REV"	TPL	7/28/06	TPL

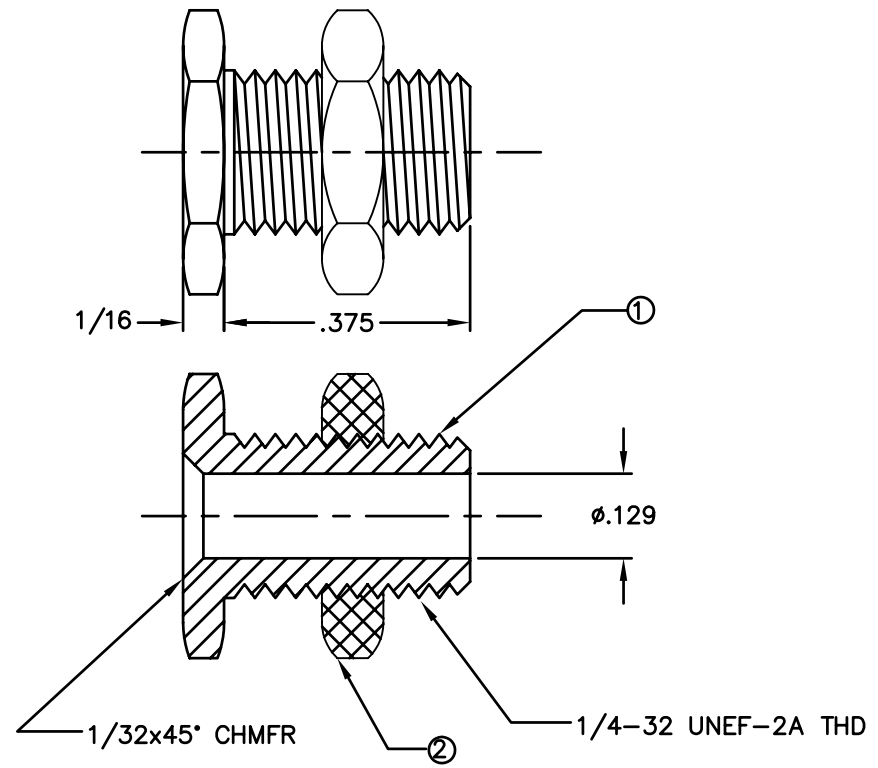
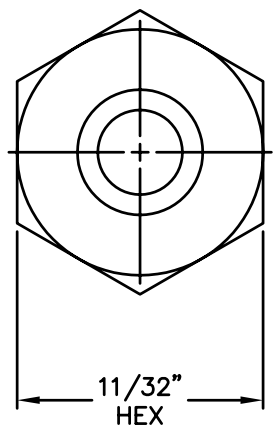

NOTE:

- 1.) ALL DIMENSIONS APPLY BEFORE PLATING
- 2.) THDS SHALL BE TO GAUGE FIT (GO/NO-GO: 2A/2B) PRE-PLATE (GO: BASIC) AFTER PLATING OR OTHER FINISH
- 3.) BREAK ALL SHARP CORNERS AND REMOVE BURRS
- 4.) INSIDE CORNERS TO HAVE R.020 MAX

THIS DRAWING AND THE INFORMATION THEREIN IS THE PROPERTY OF ABBATRON, LLC AND ALL UNAUTHORIZED USE OR REPRODUCTION THEREOF IS PROHIBITED.

MATERIAL: SEE BOM		FINISH: SEE BOM	HEAT TREAT: ---	ABBATRON Electronic Connectors and Hardware 632 Arch Street, Meadville, Pa. 16335
DIMENSIONAL TOLERANCES UNLESS OTHERWISE SPECIFIED			TITLE: 184 MINI PANEL BEARING BUSHING	
.XX	.XXX	.XXX		
---	---	---		
FRACTIONS	ANGLES	SCALE		
---	---	5:1		
SURFACE FINISH 128 ✓		☉ ---	DRAWN: T. LORD DATE: 7/28/06	SIZE: A
			CHECKED: T. LORD DATE: 7/28/06	DRAWING NUMBER: SD-184
			APPROVED: T. LORD DATE: 7/28/06	ISSUE: A