

Nov.1.2021 Copyright 2021 HIROSE ELECTRIC CO., LTD. All Rights Reserved.
In case of consideration for using Automotive equipment / device which demand high reliability, kindly contact our sales window correspondents.

1		2			3			4		
COUNT	DESCRIPTION OF REVISIONS	BY	CHKD	DATE	COUNT	DESCRIPTION OF REVISIONS	BY	CHKD	DATE	
△					△					
△					△					
△					△					

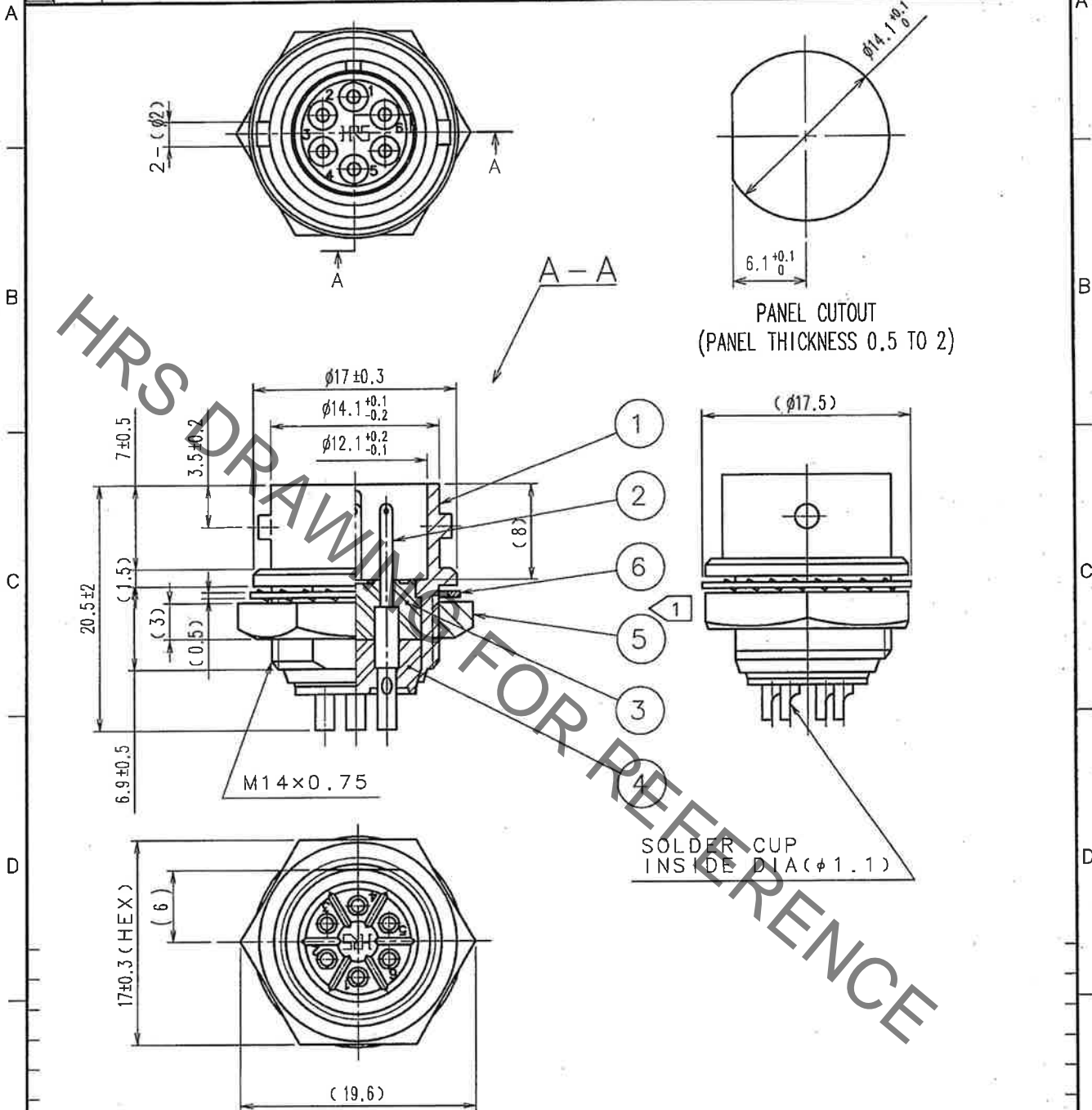

NOTE: ① THE RECOMMENDED CLAMP TORQUE OF REF.NO.⑤: 2N·m

3	DIALYL PHTHALATE (BLACK) UL94V-0	6	PHOSPHOR BRONZE NICKEL PLATING
2	COPPER ALLOY SILVER PLATING 2μ m min.	5	BRASS NICKEL PLATING
1	ZINC ALLOY MATTE FINISH NICKEL PLATED	4	DIALYL PHTHALATE (BLACK) UL94V-0
NO.	MATERIAL	FINISH, REMARKS	NO. MATERIAL FINISH, REMARKS

CODE NO. (OLD)	DRAWN	DESIGNED	CHECKED	APPROVED	RELEASED
	T. Suzuki '21.06.03	T. Suzuki '21.06.03	H. Kobayashi '21.06.07	T. Kametani '21.06.09	

 SCALE 2 : 1 UNITS mm	DRAWING NO. EDC4-027511-76-00 HIROSE ELECTRIC CO., LTD.	PART NO. RM12BRD-6PH(76) CODE NO. CL109-0827-9-76	1/1
-----------------------------------	---	--	-----

TO
R