

Applicable standard					
Rating	Operating temperature range	-35°C to +85°C(Notes 1)	Storage temperature range	-10°C to +60°C(Note3)	
	Operating humidity range	20 % to 80 % (Notes 2)	Storage humidity range	40 % to 70 %(Note3)	
	Voltage	150 V AC (DC)	Current	1 A/pin	
	Applicable Connector	DF13-*DS-1.25C	Applicable Contact	DF13(G)-2630SCFA(##) DF13-3032SCFA(##)	
Specifications					
Item	Test method	Requirements	QT	AT	
Construction					
General examination	Visually and by measuring instrument.	According to drawing.	X	X	
Marking	Confirmed visually.		X	X	
Electric characteristics					
Contact resistance	AC 20mV, 1mA (DC OR 1000 Hz).	30 mΩ MAX.	X	—	
Insulation resistance	100 V DC.	500 MΩ MIN.	X	—	
Voltage proof	500 V AC for 1 min.	No flashover or breakdown.	X	—	
Mechanical characteristics					
Mechanical operation	50 times insertions and extractions.	1) Contact resistance: 30 mΩ MAX. 2) No damage, crack or looseness of parts.	X	—	
Vibration	Frequency 10 to 55 Hz, single amplitude 0.75 mm, at 2 h, for 3 directions.	1) No electrical discontinuity of 1μs. 2) No damage, crack or looseness of parts.	X	—	
Shock	490 m/s ² duration of pulse 11 ms at 3 times for 3 directions.		X	—	
Environmental characteristics					
Rapid change of temperature	Temperature -55°C→ +85°C Time 30min→ 30min Under 5 Cycles. (The transferring time of the tank is 2 to 3 MIN)	1) Contact resistance: 30mΩ MAX. 2) Insulation resistance: 500 MΩ MIN. 3) No damage, crack or looseness of parts.	X	—	
Damp heat (Steady state)	Exposed at 40±2 °C, 90 to 95 %, 96 h.		X	—	
Resistance to soldering heat	1) Reflow soldering « Reflow area » 250°C MAX 10 sec MAX 230°C MIN 60 sec MAX « Preheating area » 170°C to 190°C 60 sec to 120 sec Put through in reflow furnace twice, leave in ambient temperature and humidity for 1 hour. 2) Manual soldering Soldering iron temperature :300°C, Soldering time: 3sec. No strength on contact.	No deformation of case of excessive looseness of the terminals.	X	—	
Solderability	Soldered at solder temperature, 245°C for insertion duration, 3sec.	Solder shall cover a minimum of 95 % of the surface being immersed.	X	—	
Remarks					
Note 1: Include the temperature rising by current.					
Note 2: No condensing					
Note 3: Apply to the condition of long term storage for unused products before mounted on PCB. After mounted on PCB, operating temperature and humidity range is applied for interim storage during transportation.					
	Count	Description of revisions	Designed	Checked	Date
△					
Unless otherwise specified, refer to IEC 60512.			Approved	HS. OKAWA	20200316
			Checked	TS. KUMAZAWA	20200316
			Designed	HK. HAYASHI	20200316
			Drawn	DS. HIROWATARI	20200311
Note QT:Qualification Test AT:Assurance Test X:Applicable Test			Drawing no.	ELC-367983-65-00	
HRS	Specification sheet		Part no.	DF13E-*DP-1. 25V (65)	
	Hirose electric co., ltd.		Code no.	CL536	△ 1/1

2022/04/07 17:36:39(JST) Taiwo Gladys Adegoke
 RoHS2(10 substances conformity)
 DRAWING FOR REFERENCE: This is subject to change without notice
 In cases where the application will demand a high level of reliability, such as automotive, please contact a company representative for further information.

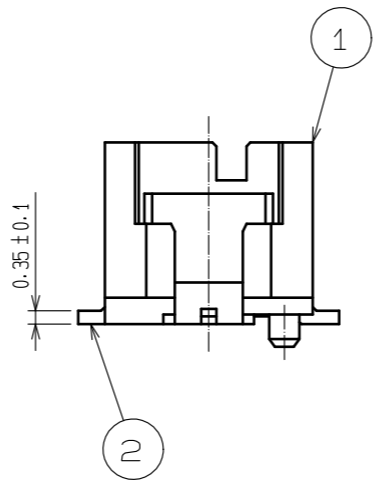

Recommended pattern

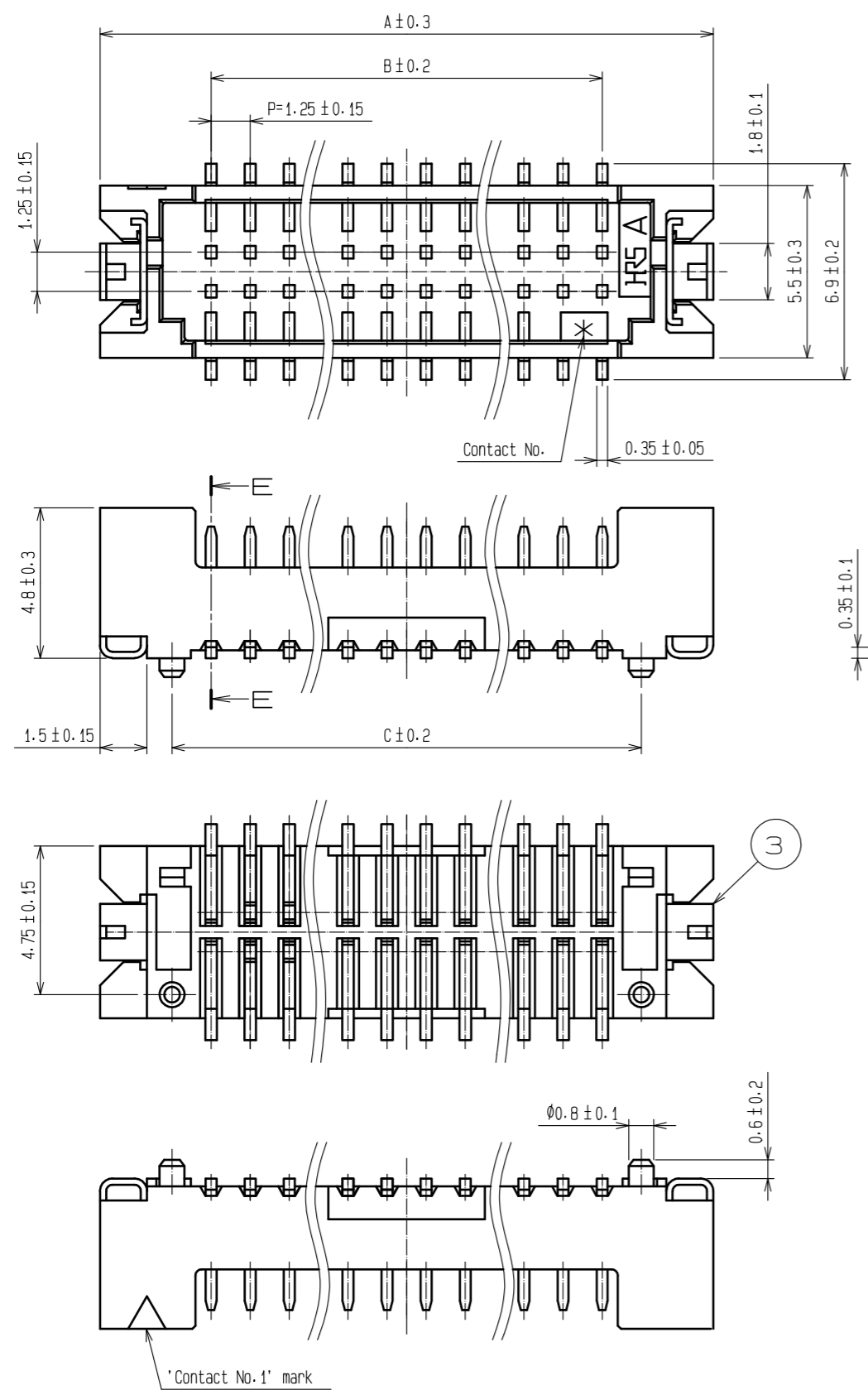
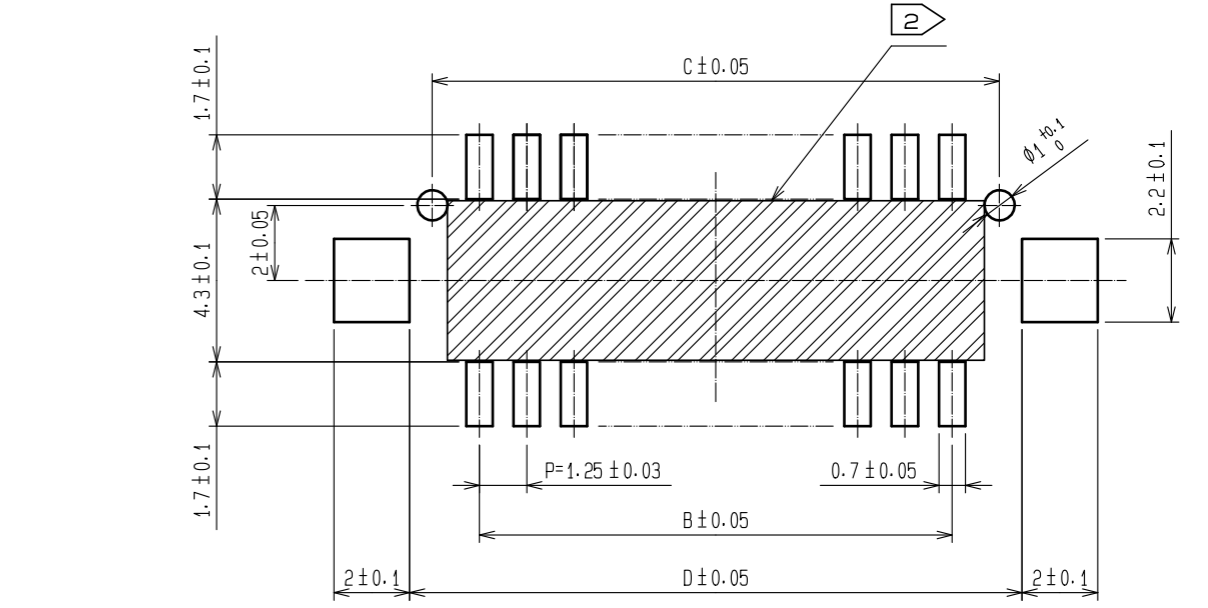

Mated connectors

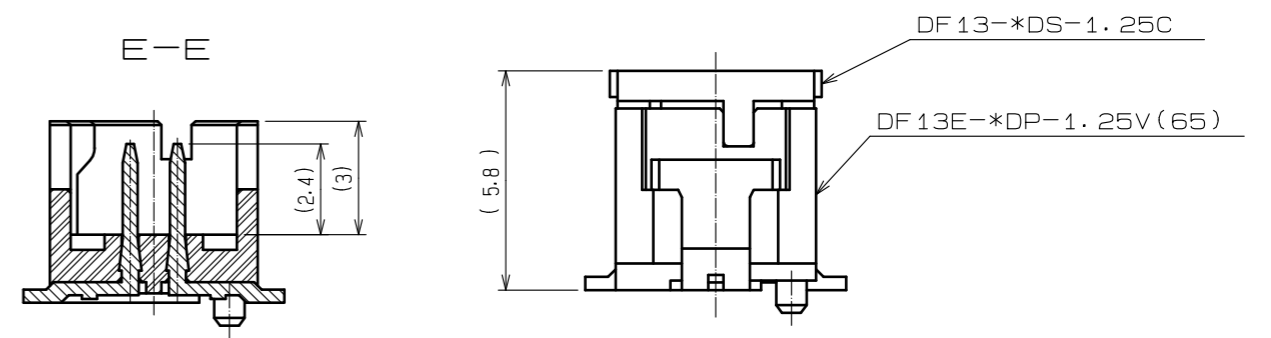

Notes 1 : Lead co-planality include reinforced metal fittings shall be 0.1mm MAX.
 ② : If there are pattern and a bia hole on part, there is a possibility that it will make contact with the leads.

Part No.	Number of contacts	Code No.	A	B	C	D
DF13E-10DP-1.25V(65)	10	CL536-0566-0-65	12.1	5.0	7.5	8.7
DF13E-20DP-1.25V(65)	20	CL536-0567-0-65	18.35	11.25	13.75	14.95
DF13E-30DP-1.25V(65)	30	CL536-0568-0-65	24.60	17.50	20.00	21.20
DF13E-40DP-1.25V(65)	40	CL536-0569-0-65	30.85	23.75	26.25	27.45

NO.	MATERIAL	FINISH	REMARKS	NO.	MATERIAL	FINISH	REMARKS
2	Brass		Contact area:Gold plated 0.2µm MIN Lead area:Tin plated 1µm MIN Under plating:Nickel 1µm MIN	5	Elastomer		Gray
1	Polyamide		Beige,UL94V-0	4	R.PVC		Electrostatic protection,Clear
				3	Phosphor bronze		Tin plated 1µm MIN

UNITS	SCALE	COUNT	DESCRIPTION OF REVISIONS	DESIGNED	CHECKED	DATE
mm	5 : 1	△				

APPROVED : HS. OKAWA	20200330	DRAWING NO.	EDC-367983-65-00
CHECKED : TS. KUMAZAWA	20200330	PART NO.	DF13E-*DP-1.25V(65)
DESIGNED : HK. HAYASHI	20200330	CODE NO.	CL536-
DRAWN : DS. HIROWATARI	20200326		

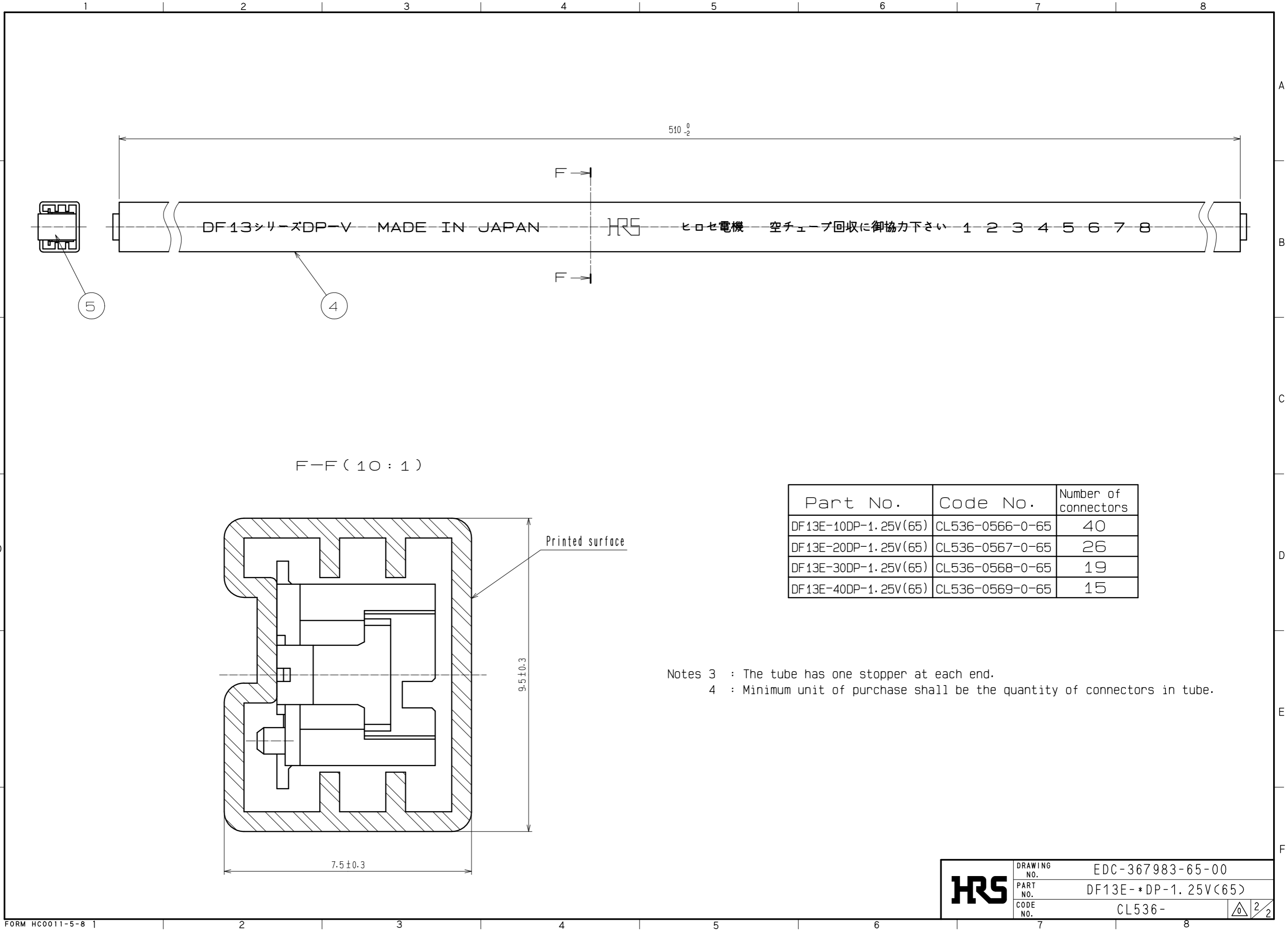

HRS

DRAWING NO.	EDC-367983-65-00
PART NO.	DF13E-*DP-1.25V(65)
CODE NO.	CL536-

2/2