

ISS.	AMEND	DATE
1	ISSUED	25/7/19
2	UPDATED	13/3/2020

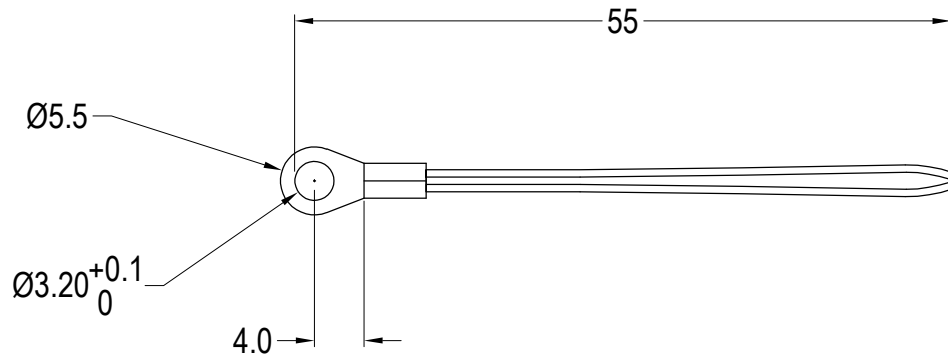

MULTI-STRAND NYLON
CORD Ø0.55
MUST NOT PULL OUT



TIN PLATED BRASS
CRIMP RING TERMINAL

RoHS
COMPLIANT

TOLERANCE
NO DEC. PLACE ± 1.00
1 DEC. PLACE ± 0.20
2 DEC. PLACE ± 0.10
HOLE Ø ± 0.10
ANGLES ± 0.5°
UNLESS OTHERWISE STATED

DO NOT SCALE

Cliff Electronic Components Ltd.

76 Holmethorpe Avenue, Holmethorpe Industrial Estate,
Redhill, Surrey, RH1 2PF, England, UK
Tel: 01737-771375 Fax: 01737-766012 Website: www.cliffuk.co.uk

DIMENSIONS IN MILLIMETERS UNLESS OTHERWISE STATED. WORK TO DIMENSIONS. REMOVE ALL BURRS. IF IN DOUBT ASK.

3rd ANGLE PROJECTION:

MATERIAL: BRASS / TIN PLATE / NYLON

TITLE: DUST COVER LANYARD

FINISH: CLEAN

THE CONTENTS OF THIS DOCUMENT MUST NOT BE COPIED OR DISCLOSED TO A 3rd PARTY WITHOUT WRITTEN PERMISSION OF CLIFF UK. © 2019

DRAWN: D.P.J.

APPROVED: C.A.M.J

DRWG. No. CP30290

FORM: A4DRWGH