

NOTES:

1. LENS WITH INDICATOR AND GASKET SHIPPED UNASSEMBLED.
2. MATERIAL: POLYCARBONATE LENS WITH PAPER INDICATOR & IP RATED POLYURETHANE SEALING GASKET WITH ADHESIVE.
3. ASSEMBLY INSTRUCTIONS FOR IP68 RATING
 - CLEAN PANEL SURFACE WITH ALCOHOL
 - PEEL LINER TAPE OFF ONE SIDE OF THE SEALING GASKET
 - SLIDE SEALING GASKET ONTO INSTALLATION TOOL OR 0.264" PIN GAUGE AND INSERT THE TOOL/GAUGE IN MOUNTING HOLE. USE TOOL/GAUGE TO GUIDE SEALING GASKET TOWARDS MOUNTING HOLE AS CENTERED AS POSSIBLE. PEEL REMAINING LINER TAPE SLOWLY AWAY
 - INSERT LENS CAP INTO PANEL UNTIL LENS TABS ENGAGE WITH PANEL ON OPPOSITE SIDE
4. RECOMMENDED FOR USE WITH < 35 MCD LUMINOUS INTENSITY & > 620 NM DOMINANT WAVELENGTH LEDS

REVISIONS			
REV.	DESCRIPTION	DATE	APPROVED
A	ENGINEERING RELEASE	8/1/2022	A.V.

PART NUMBER CONFIGURATION

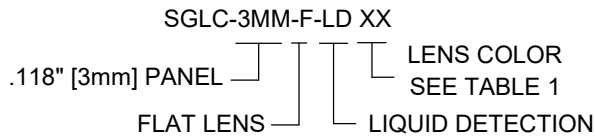

ORDER CODE	LENS APPEARANCE
(BLANK)	CLEAR
BE	TINTED BLUE
GN	TINTED GREEN
YW	TINTED YELLOW

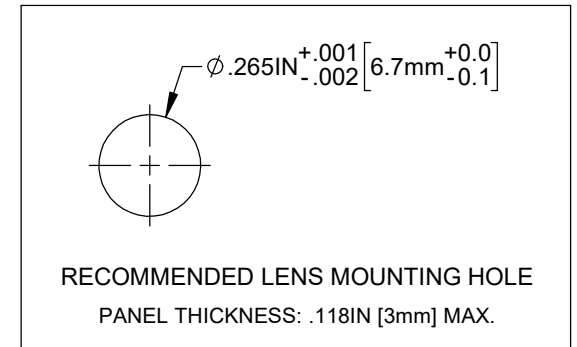
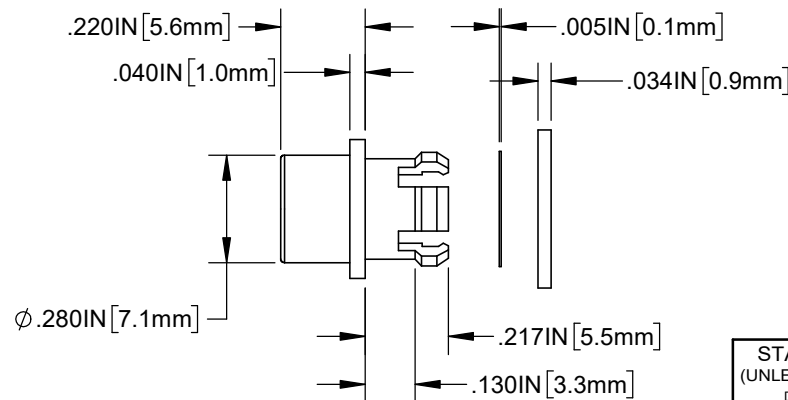
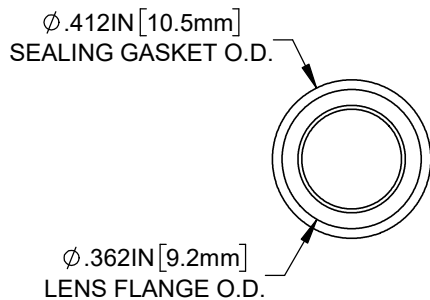
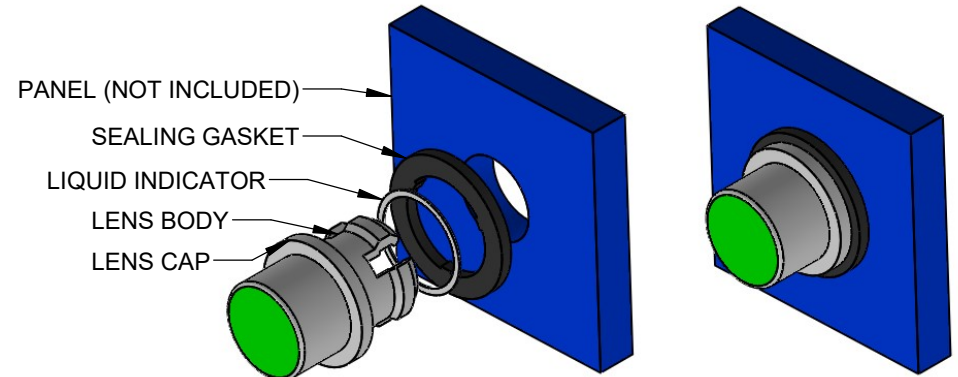

CUSTOMER USE DRAWING

SAMPLE PART NUMBER



STANDARD TOLERANCE (UNLESS OTHERWISE SPECIFIED)		 4 THOMAS, IRVINE, CA. 92618 TEL: (949) 951-8808 FAX: (949) 951-3974	
DECIMALS	ANGULAR		
.X ± .1	X° ± 1°	TITLE: IP68 LENS CAP	
.XX ± .01		DESIGNED: E. CHAN	DATE: 8/1/2022
.XXX ± .005		REVISION: A	REVISION: A
		DRAWING NO: SGLC-3MM-F-LD XX	REVISION: A
		SHEET SIZE: A	CAGE CODE: 32559
		SCALE: 2:1	SHEET # 1 OF 2
CHECKED: A. VALDEZ		DATE: 8/1/2022	CAD GENERATED DOCUMENT, DO NOT MEASURE DRAWING

FOR OPTIMAL LIGHT DISTRIBUTION FOLLOW PRODUCT PLACEMENT INSTRUCTIONS LISTED BELOW:

PRODUCTS INSERTED COMPLETELY INSIDE LENS CAP:

- * LPR5 LIGHT PIPE SERIES
- * 5mm DISCRETE LEDS

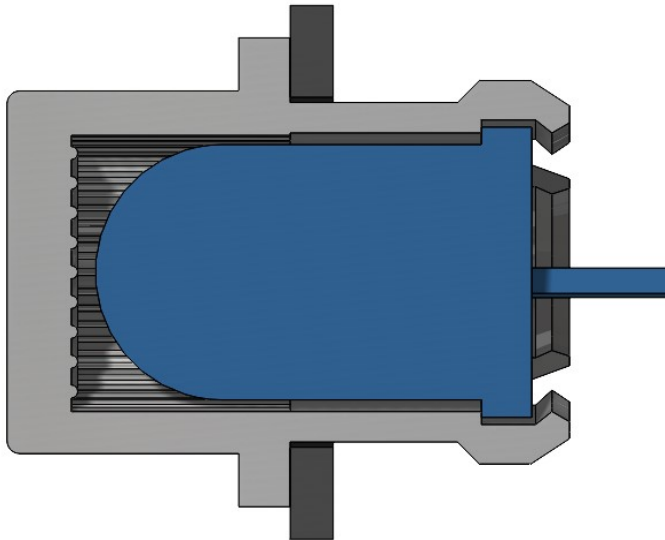

PRODUCTS RECESSED & FLUSH WITH PANEL:

- * 1.8mm DISCRETE LEDS
- * 3mm DISCRETE LEDS
- * LPR4 LIGHT PIPE SERIES
- * LPV4 LIGHT PIPE SERIES
- * VLP LIGHT PIPE SERIES
- * SLP3 LIGHT PIPE SERIES
- * RLP1 LIGHT PIPE SERIES

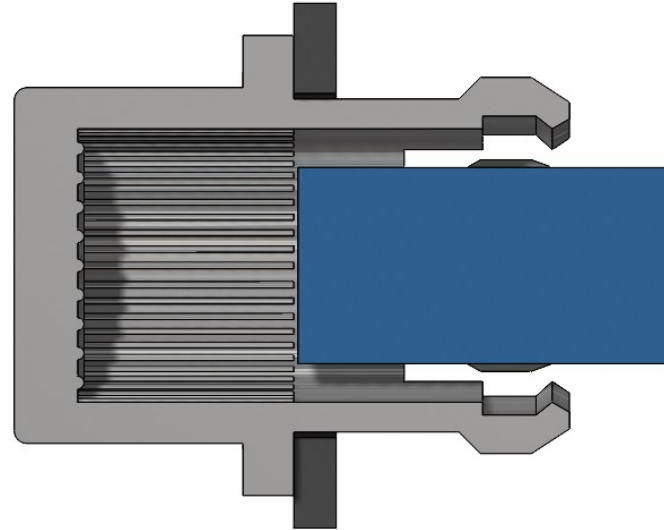

CUSTOMER USE DRAWING

		BIVAR [®]		REVISION:
CAGE CODE:	32559	DRAWING NO:	SGLC-3MM-F-LD XX	A
SHEET SIZE:	A	SCALE:	2:1	SHEET # 2 OF 2
CAD GENERATED DOCUMENT, DO NOT MEASURE DRAWING				