

NO CONTACTS AT
1 AND 17 POSITION
FOR 299-017-299-198

TOLERANCE
UNLESS OTHERWISE
SPECIFIED IN MM:
X.X ±0.2
X.XX ±0.10
X.XXX ±0.050

THIS IS A C.A.D. GENERATED DRAWING
DO NOT MAKE MANUAL REVISIONS TO MASTER.



ISSUE NUMBER

ORIGINAL

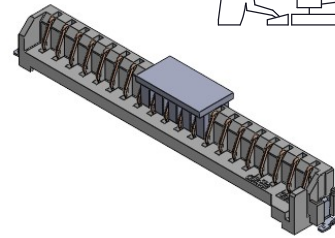
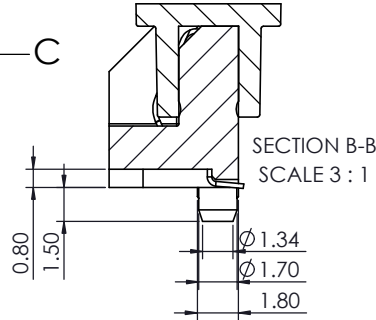
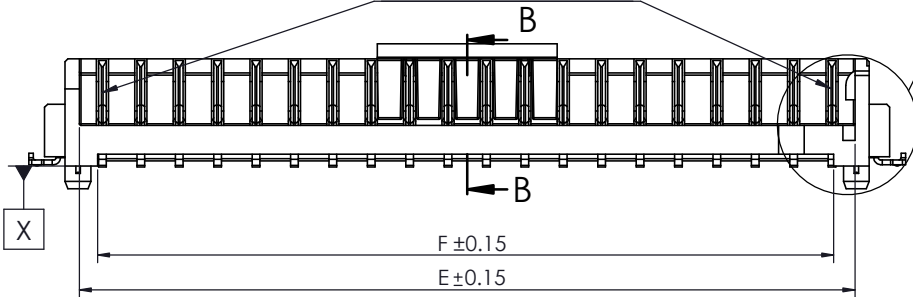

NOTE:

1. MATERIAL

HOUSING: LCP + 30GF, NATURAL, UL 94V-0
TERMINAL: PHOSPHOR BRONZE C5191-EH, (t=0.2mm)
CAP: PA 6T; COLOR BLACK

2. TERMINAL PLATING

CONTACT AREA: GOLD FLASH
SOLDER TAIL AREA: TIN PLATING
ALL OVER NICKEL UNDER PLATING

3. TAIL COPLANARITY

TAILS TO BE WITHIN 0.02 UPWARD AND 0.15
DOWNWARD FROM X-DATUM PLANE, AND
TAIL COPLANARITY TO BE 0.15.

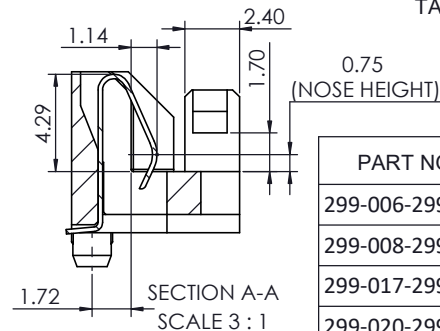
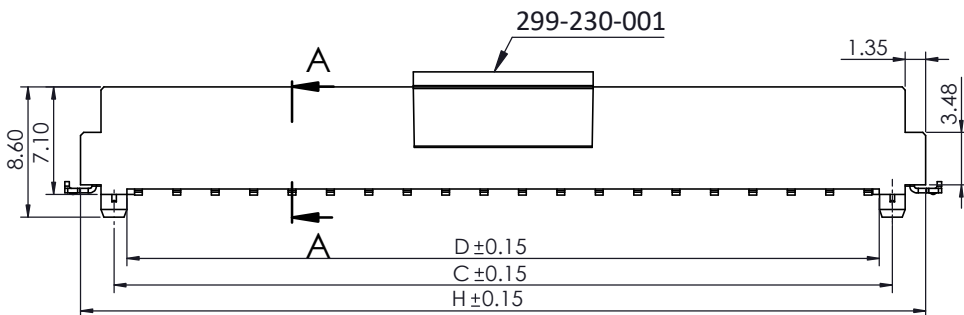
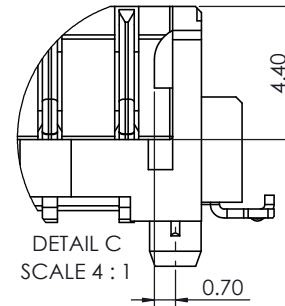
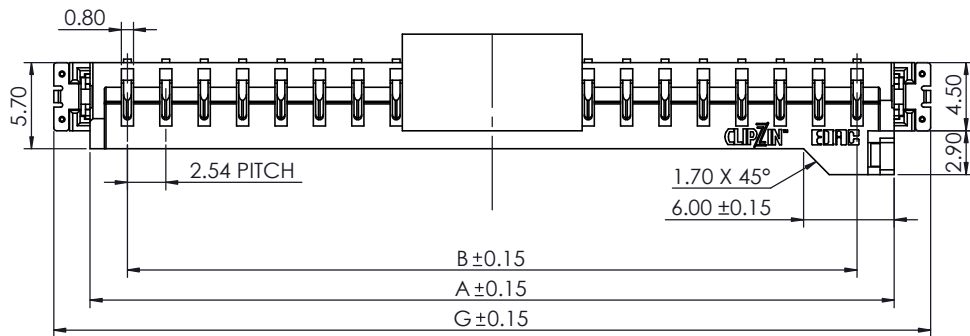

PART NO.	A	B	C	D	E	F	G	H
299-006-299-198	17.64	12.70	15.92	14.20	15.74	13.14	22.44	20.34
299-008-299-198	22.72	17.78	21.00	19.28	20.82	18.22	27.52	25.42
299-017-299-198	45.58	40.64	43.86	42.14	43.68	41.08	50.38	48.28
299-020-299-198	53.20	48.26	51.48	49.76	51.30	48.70	58.00	55.90

SMT TYPE, CARD EDGE CUSTOM CONNECTOR WITH STABILISER

DRAWN: S.M DATE: 10/08/2022

CHECKED: R.S.M DATE: 10/08/2022

PART NUMBER

299-0XX-299-198 SHEET 1 OF 2

DRAWING NUMBER

299-0XX-299-198 ISSUE P1



THIS SERIES FULLY CONFORMS TO THE
EUROPEAN UNION DIRECTIVES 2011/65/EU
RoHS COMPLIANCY.



YOUR CONNECTION TO QUALITY & SERVICE

EDAC INC
TORONTO, ONTARIO
CANADA

THESE DRAWINGS AND SPECIFICATIONS
ARE THE PROPERTY OF EDAC INC., AND
SHALL NOT BE REPRODUCED, OR COPIED
OR USED AS THE BASIS FOR THE
MANUFACTURE OR SALE OF APPARATUS
WITHOUT WRITTEN PERMISSION.

THIS IS A C.A.D. GENERATED DRAWING
DO NOT MAKE MANUAL REVISIONS TO MASTER.

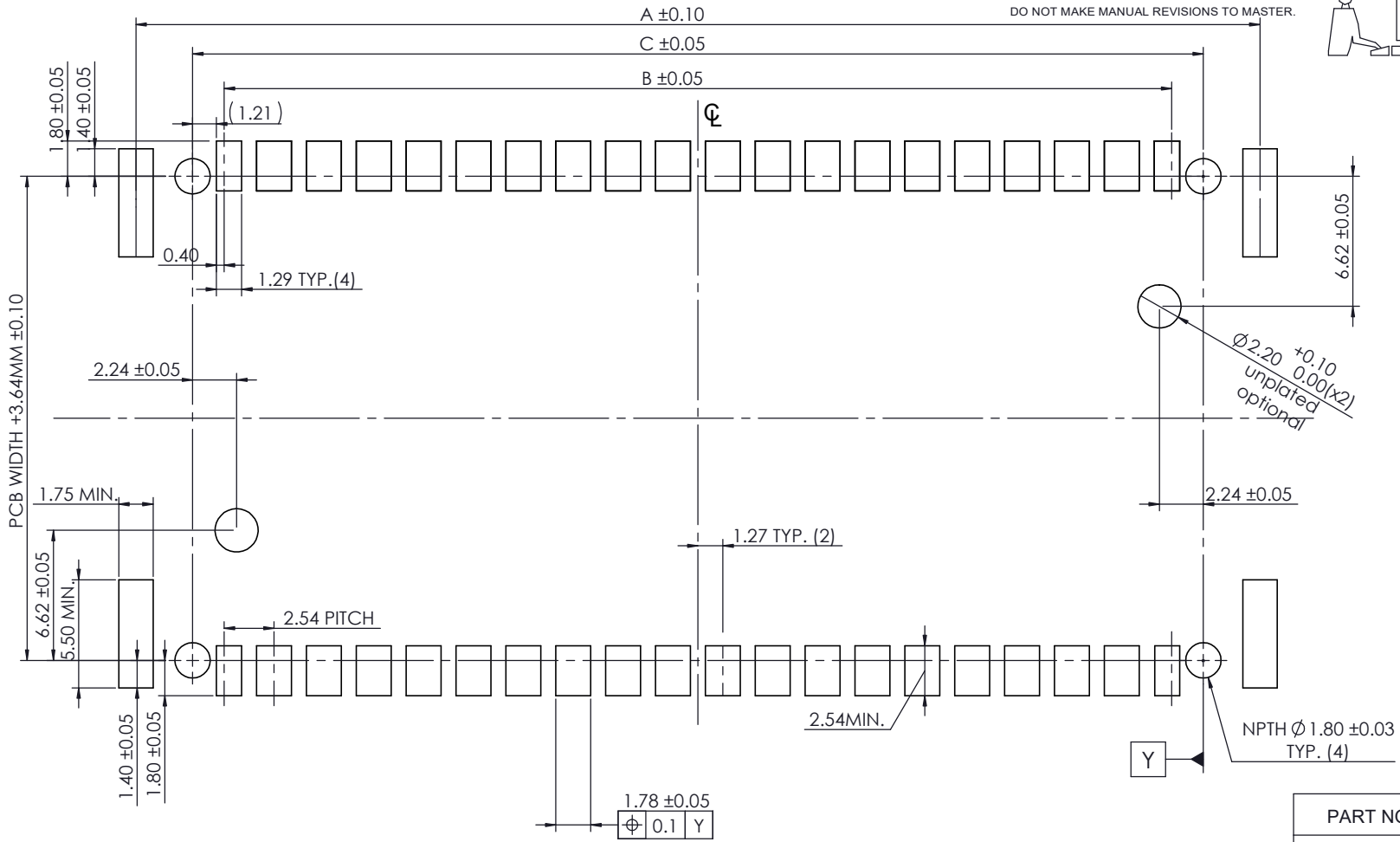

RECOMMENDED PCB LAYOUT
RECOMMENDED TOL. ±0.05MM



THIS SERIES FULLY CONFORMS TO THE
EUROPEAN UNION DIRECTIVES 2011/65/EU
RoHS COMPLIANCY.

**SMT TYPE, CARD EDGE CUSTOM CONNECTOR
WITH STABILISER
RECOMMENDED LAYOUT**



EDAC INC
TORONTO, ONTARIO
CANADA

YOUR CONNECTION TO QUALITY & SERVICE

THESE DRAWINGS AND SPECIFICATIONS
ARE THE PROPERTY OF EDAC INC., AND
SHALL NOT BE REPRODUCED, OR COPIED
OR USED AS THE BASIS FOR THE
MANUFACTURE OR SALE OF APPARATUS
WITHOUT WRITTEN PERMISSION.

PART NO.	A	B	C
299-006-299-198	21.69	12.70	15.92
299-008-299-198	26.77	17.78	21.00
299-017-299-198	49.63	40.64	43.86
299-020-299-198	57.25	48.26	51.48

DRAWN: S.M	DATE: 10/08/2022
CHECKED: R.S.M	DATE: 10/08/2022
PART NUMBER 299-0XX-299-198	
SHEET 2 OF 2	
DRAWING NUMBER 299-0XX-299-198	ISSUE P1