

This document is the property of Amphenol Corporation and is delivered on the express condition that it is not to be disclosed, reproduced or used, in whole or in part, for manufacture or sale by anyone other than Amphenol Corporation without its prior consent, & that no right is granted to disclose or to use any information in this document.

# CUSTOMER DRAWING

REVISIONS				
SYM	ECN	DESCRIPTION	DATE	APPROVED
1	20XXXXXXX	NEW RELEASE	2021/01/11	Michael.Qin
2	20XXXXXXX	Modify PCB Layout design	2022/06/09	Michael.Qin
3	20XXXXXXX	Modify PCB Layout design	2022/06/10	Michael.Qin
3	20XXXXXXX	Update package contents	2022/06/21	Michael.Qin

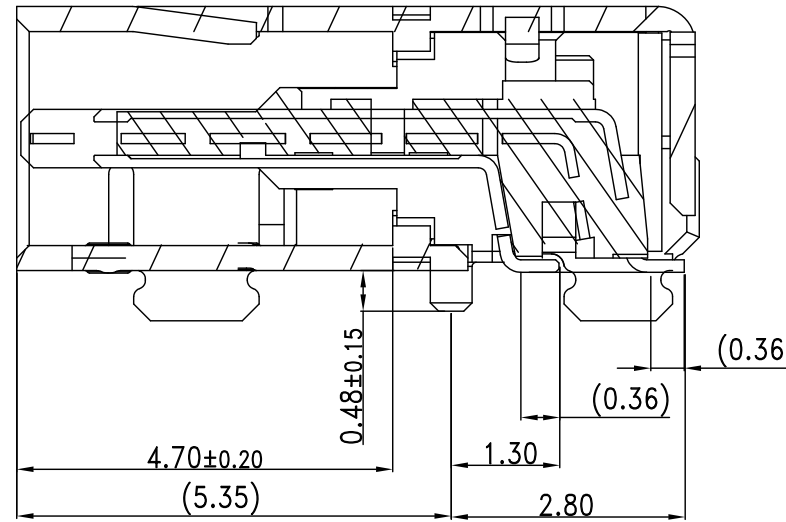
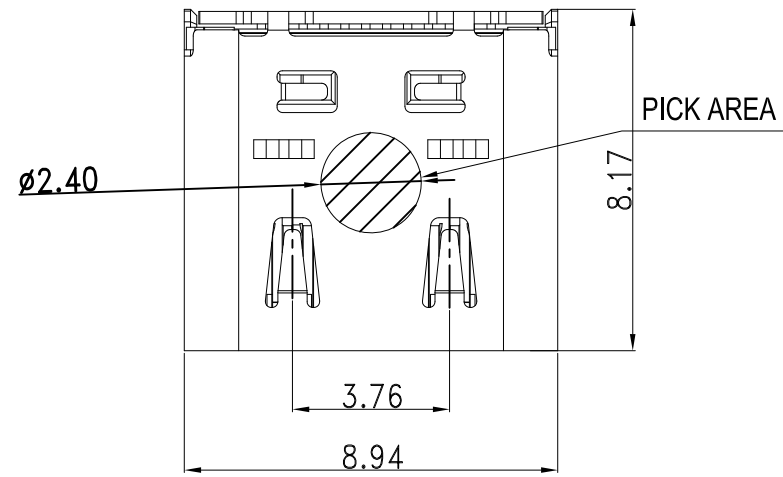

SECTION A-A (剖视图A-A)  
SCALE 2:1 (比例 2:1)

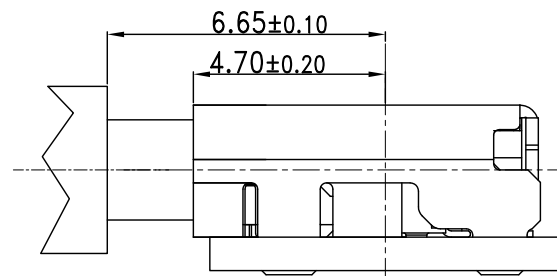
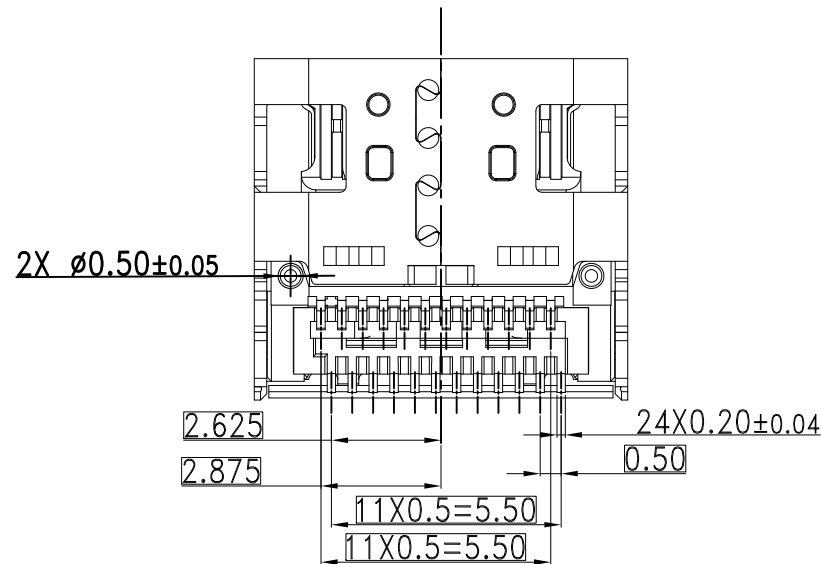
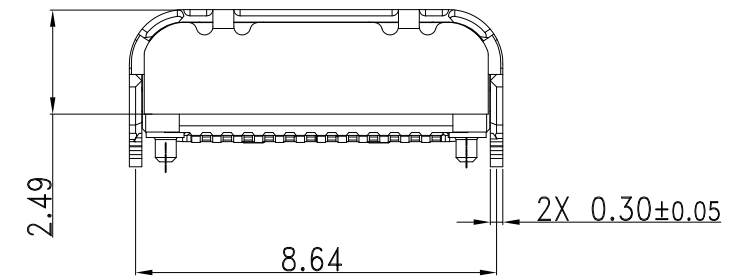
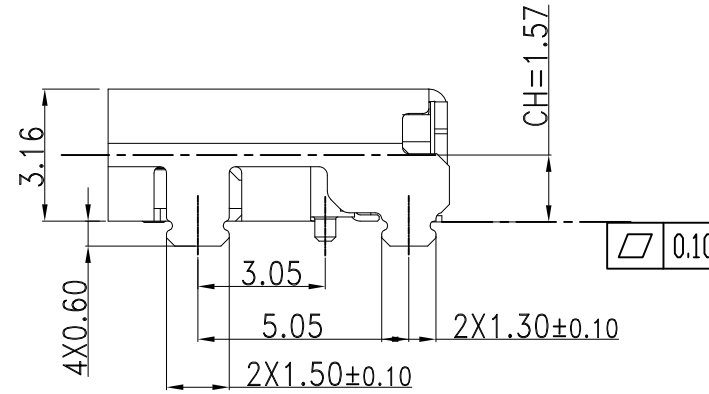
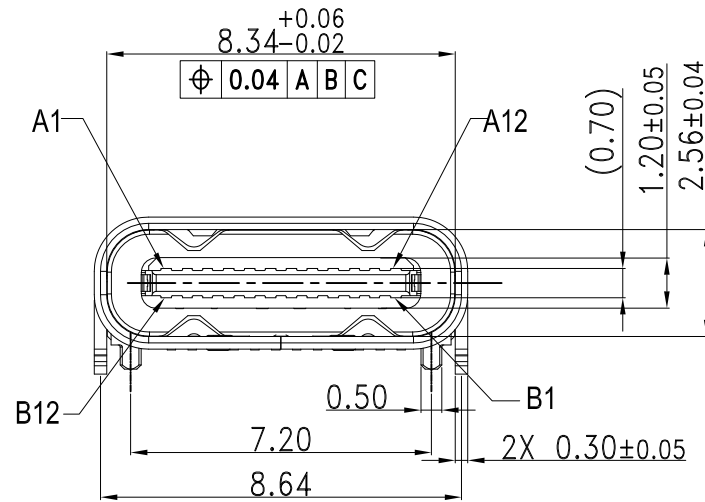
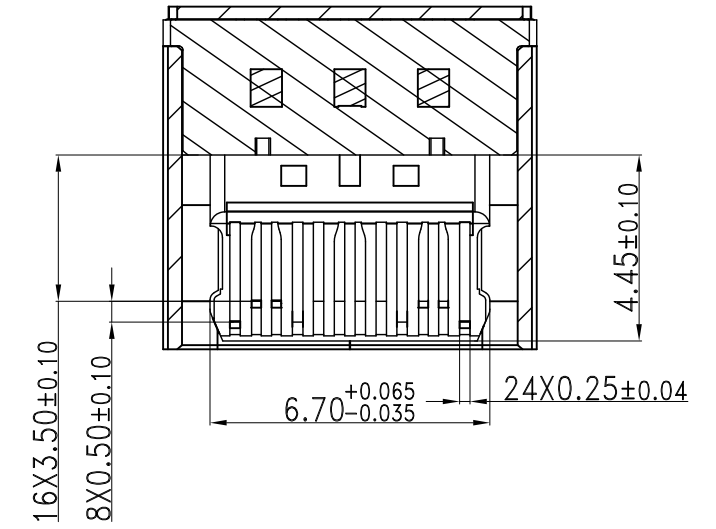

MATED CONDITION(REF.)

HF (无卤)	√
NOT-HF (有卤)	



Pin定义:

A1	A2	A3	A4	A5	A6	A7	A8	A9	A10	A11	A12
GND	TX1+	TX1-	Vbus	CC1	D+	D-	SBU1	Vbus	RX2-	RX2+	GND
GND	RX1+	RX1-	Vbus	SBU2	D-	D+	CC2	Vbus	TX2-	TX2+	GND
B12	B11	B10	B9	B8	B7	B6	B5	B4	B3	B2	B1

UNLESS OTHERWISE SPECIFIED TOLERANCES	U.S.	METRIC	APPROVAL	DATE	<b>Amphenol</b> Amphenol East Asia Limited TITLE: Customer Drawing For <b>USB4 TYPE C CONNECTOR TOP MOUNT</b> <b>CH=1.57mm</b>
	.X	+/-		0.50	
.XX	+/-	0.20	DRAWN: <b>Fel.Wu</b>		
.XXX	+/-	0.10	CHECKED: <b>Michael.qin</b>	05/11/20	
FRACTIONS	+/-		CHECKED:		
ANGLES	+/-	3°	DRAWING FILE: R:\DCI\Engineering data\RD\I.T. 程图客户图		
FOR MATERIALS AND FINISHES SEE NOTES			REMOVE SHARP EDGES		ANGLE OF PROJECTION
DIMENSIONS			U.S. INCHES		
(METRIC)			(MM)		SIZE: A3 DRAWING NO.: C 12402143 SCALE: NONE SHEET 1 OF 3

This document is the property of Amphenol Corporation and is delivered on the express condition that it is not to be disclosed, reproduced or used, in whole or in part, for manufacture or sale by anyone other than Amphenol Corporation without its prior consent, & that no right is granted to disclose or to use any information in this document.

# CUSTOMER DRAWING

REVISIONS				
SYM	ECN	DESCRIPTION	DATE	APPROVED

## NOTES/注释:

- MATERIAL/材料: SEE TABLE/见下表
- GENERAL SPECIFICATION/通用特性:
  - COPLANARITY /共面度: 0.10 Max.
  - CURRENT RATING: 5A / 额定电流: 5安培
  - CONTACT RESISTANCE: 40mΩ MAX (INITIAL).  
INSULATION RESISTANCE: 100MΩ Min  
接触电阻: 40毫欧最大(初始值) / 绝缘电阻: 100MΩ Min
  - DIELECTRIC WITHSTANDING VOLTAGE: 100 VAC  
耐电压: 100伏交流
  - MECHANICAL CHARACTERISTICS:  
INSERTION FORCE: 5~20N EXTRACTION FORCE: 8~20N  
AFTER DURABILITY EXTRACTION FORCE: 6~20N  
力学特性: 初始插入力: 5~20N 拔出力: 8~20N  
耐久后拔出力: 6~20N
  - DURABILITY: 10000 CYCLES / 耐久性: 10000次
  - PACKAGING TYPE: CARRIER TAPE./ 包装类型: 载带包装
- DIMENSIONING SHALL BE INTERPRETED PER ASME Y14.5M 1994.  
尺寸标注基于ASME Y14.5M 1994标准规范
- MATERIAL SHOULD BE FULFILLED AMPHENOL SPEC.# S-SN-002, FOR HALOGEN FREE PRODUCTS, ALSO NEED TO MEET S-SN-004.  
产品材料环保标准为Amphenol SSN#002,如果是无卤产品需满足标准SSN#004
- ORDER P/N SYSTEM/产品料号编码系统 : 12402143E512A

### Plating Spec:

- E5: Mating Area: Au 30u" Min  
Solder Area: Gold flash  
50u"Min Nickel Under Plating Over All
- E2: Mating Area: Gold flash  
Solder Area: Gold flash  
50u"Min Nickel Under Plating Over All

- A: HF
- Package Spec. 2: Reel
- Date Code Description  
0: Without D/C  
1: With D/C

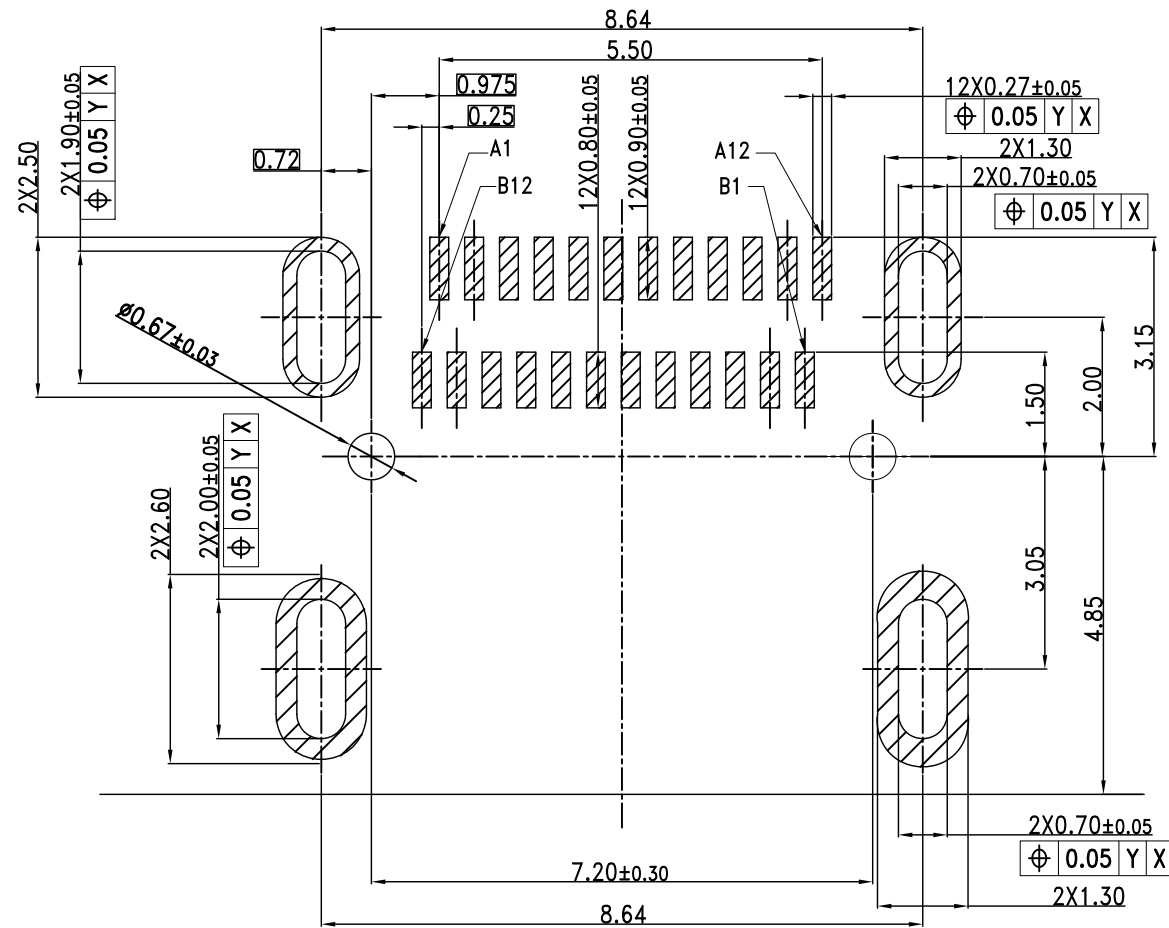

Recommended PCB Layout (Top View) / 推荐的PCB布局 (前视图)  
General Tolerances: ±0.05 / 一般公差: ±0.05

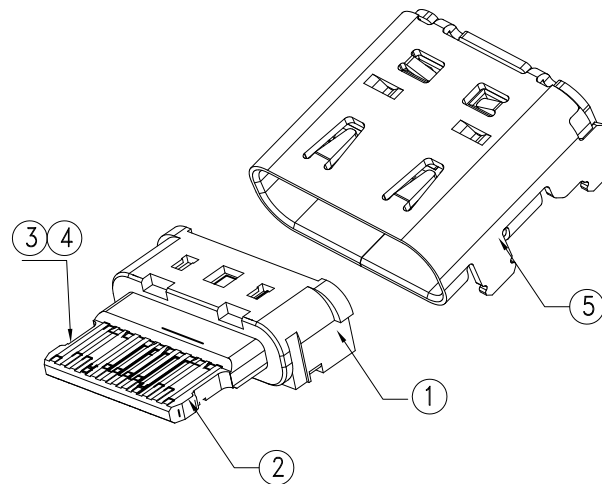

HF (无卤)	√
NOT-HF (有卤)	

ITEM	DESCRIPTION	Q'TY	MATERIAL	FINISH
5	INNER-SHELL	1	STAINLESS STEEL	SOLDER NICKEL: NIKE 50u" MIN
4	TOP TERMINAL	1	COPPER ALLOY	SEE NOTES
3	BOTTOM TERMINAL	1	COPPER ALLOY	SEE NOTES
2	MID PLATE	1	STAINLESS STEEL	SOLDER NICKEL: 50U" MIN
1	MAIN HOUSING	1	HIGH TEMPERATURE PLASTIC	BLACK

BILL OF MATERIAL				
UNLESS OTHERWISE SPECIFIED TOLERANCES U.S. METRIC .X +/- 0.50 .XX +/- 0.20 .XXX +/- 0.10 FRACTIONS +/- ANGLES +/- 3'	APPROVAL	DATE	<b>Amphenol</b> Amphenol East Asia Limited TITLE: Customer Drawing For <b>USB4 TYPE C CONNECTOR TOP MOUNT CH=1.57mm</b>	
	DRAWN: <b>Fel.Wu</b>	05/11/20		
	CHECKED: <b>Michael.qin</b>	05/11/20		
FOR MATERIALS AND FINISHES SEE NOTES	DRAWING FILE: R:\DCI\Engineering\data\RD\T.程图\客户图		SIZE	DRAWING NO.
REMOVE SHARP EDGES	ANGLE OF PROJECTION		A3	C 12402143
DIMENSIONS			SCALE	NONE
U.S. INCHES			SHEET	2 OF 3
(METRIC) (MM)			REV.	4

This document is the property of Amphenol Corporation and is delivered on the express condition that it is not to be disclosed, reproduced or used, in whole or in part, for manufacture or sale by anyone other than Amphenol Corporation without its prior consent, & that no right is granted to disclose or to use any information in this document.

# CUSTOMER DRAWING

REVISIONS				
SYM	ECN	DESCRIPTION	DATE	APPROVED

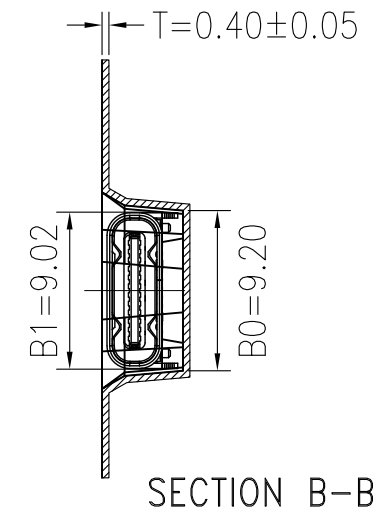
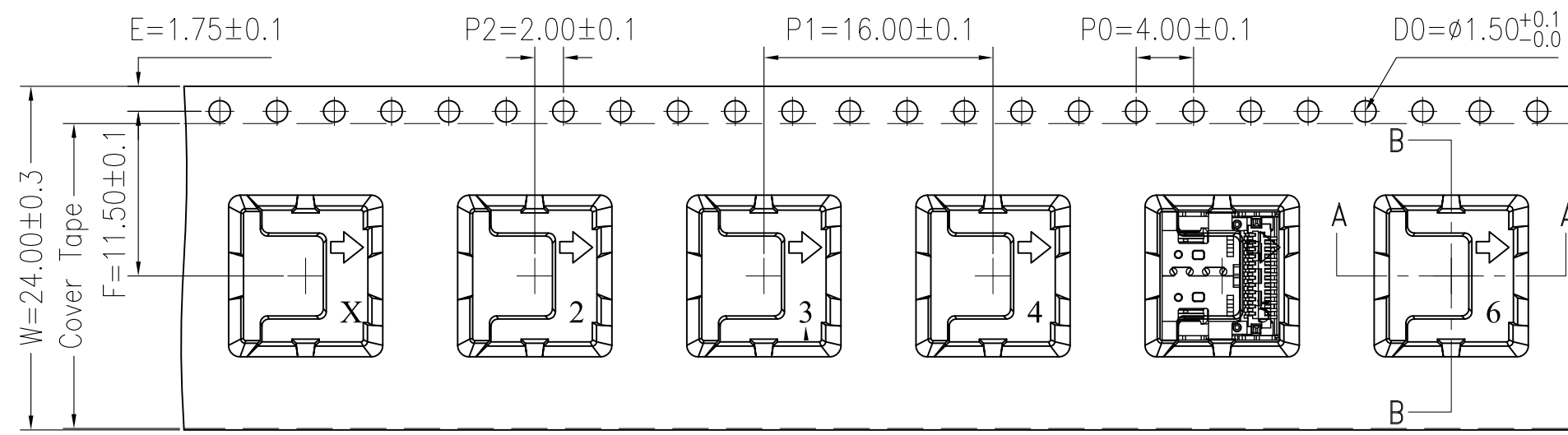

载带卷料方向

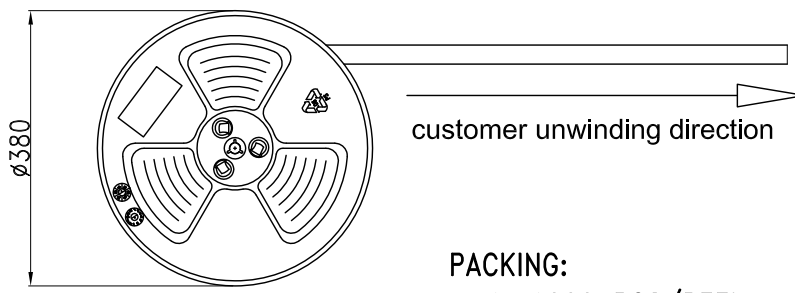
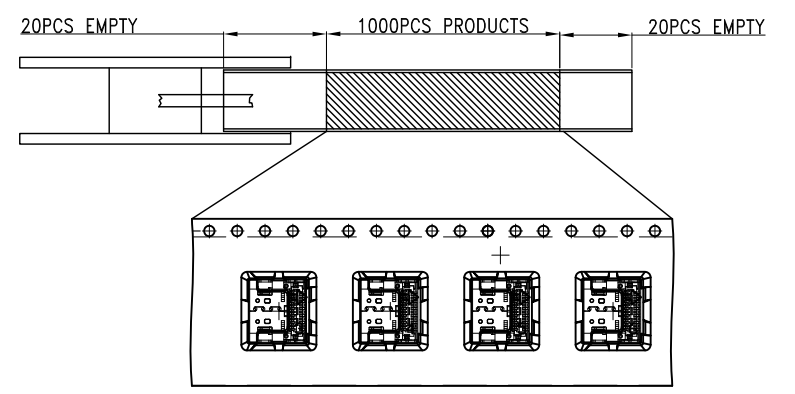
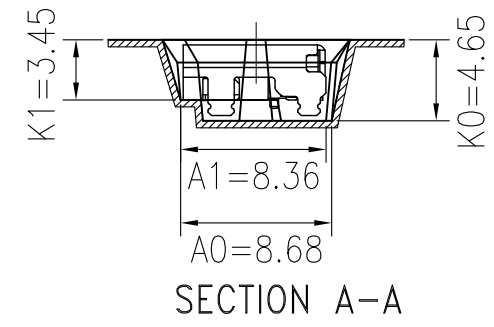

**PACKING:**  
 1. 1000 PCS/REEL.  
 2. 8 REEL/CARTON.

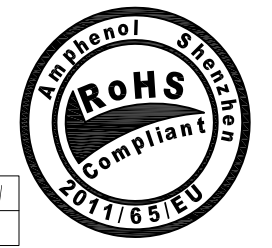
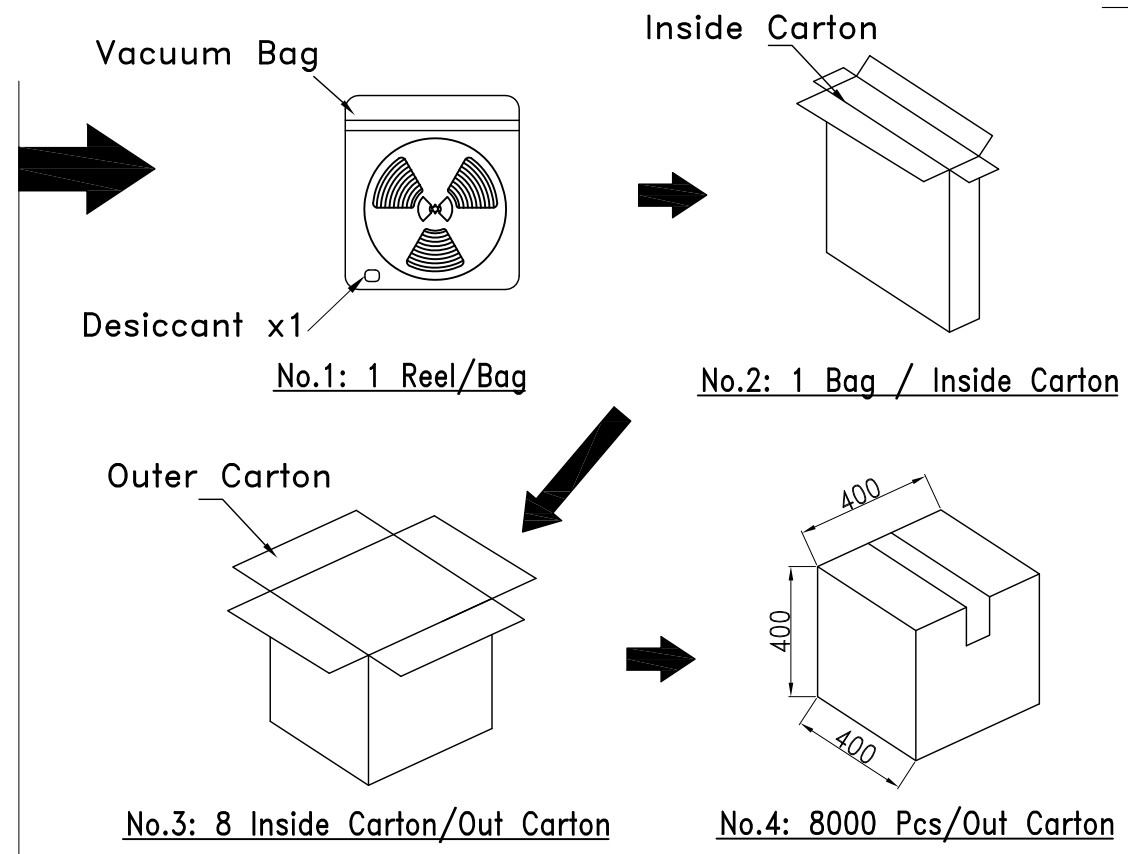

HF(无卤)	√
NOT-HF(有卤)	

UNLESS OTHERWISE SPECIFIED TOLERANCES	APPROVAL	DATE	Amphenol Amphenol East Asia Limited
	DRAWN <b>Fel.Wu</b>	<b>05/11/20</b>	
.X +/- 0.50	CHECKED <b>Michael.qin</b>	<b>05/11/20</b>	TITLE Customer Drawing For <b>USB4 TYPE C CONNECTOR TOP MOUNT CH=1.57mm</b>
.XX +/- 0.20	CHECKED		
.XXX +/- 0.10	DRAWING FILE : R:\DCI\Engineering\data\RD\T.程图客户楼		SIZE DRAWING NO.
FRACTIONS +/-	REMOVE SHARP EDGES		<b>A3</b> <b>C 12402143</b>
ANGLES +/- 3'	DIMENSIONS		REV. <b>4</b>
FOR MATERIALS AND FINISHES SEE NOTES	ANGLE OF PROJECTION		SCALE <b>NONE</b>
	U.S. INCHES		SHEET <b>3 OF 3</b>
	(METRIC) (MM)		