

P	LTR	DESCRIPTION	DATE	DWN	APVD
	A	NEW DRAWING	08JUN2022	GK	DB

LABEL AND LINER DESIGN

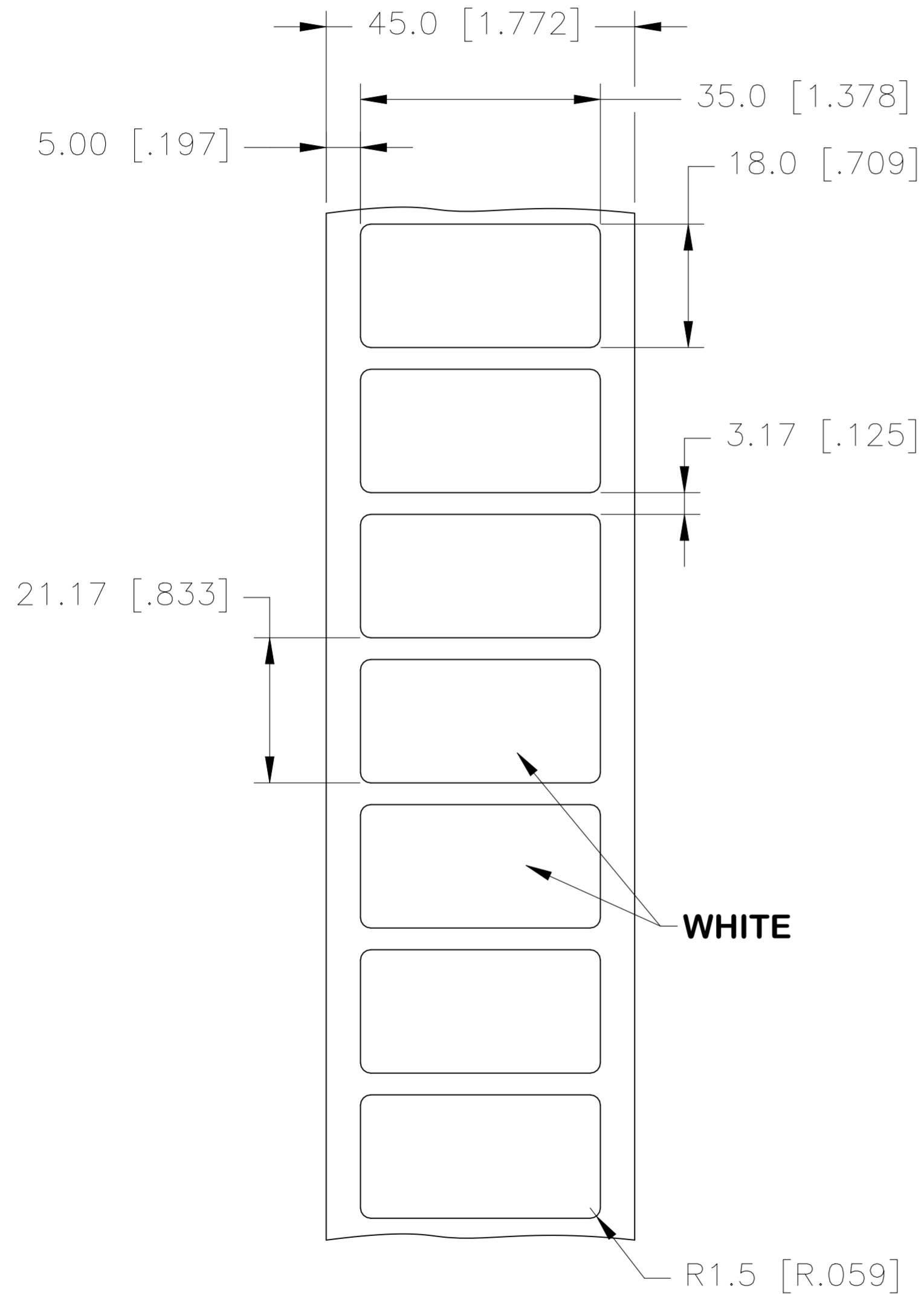

PRESENTATION

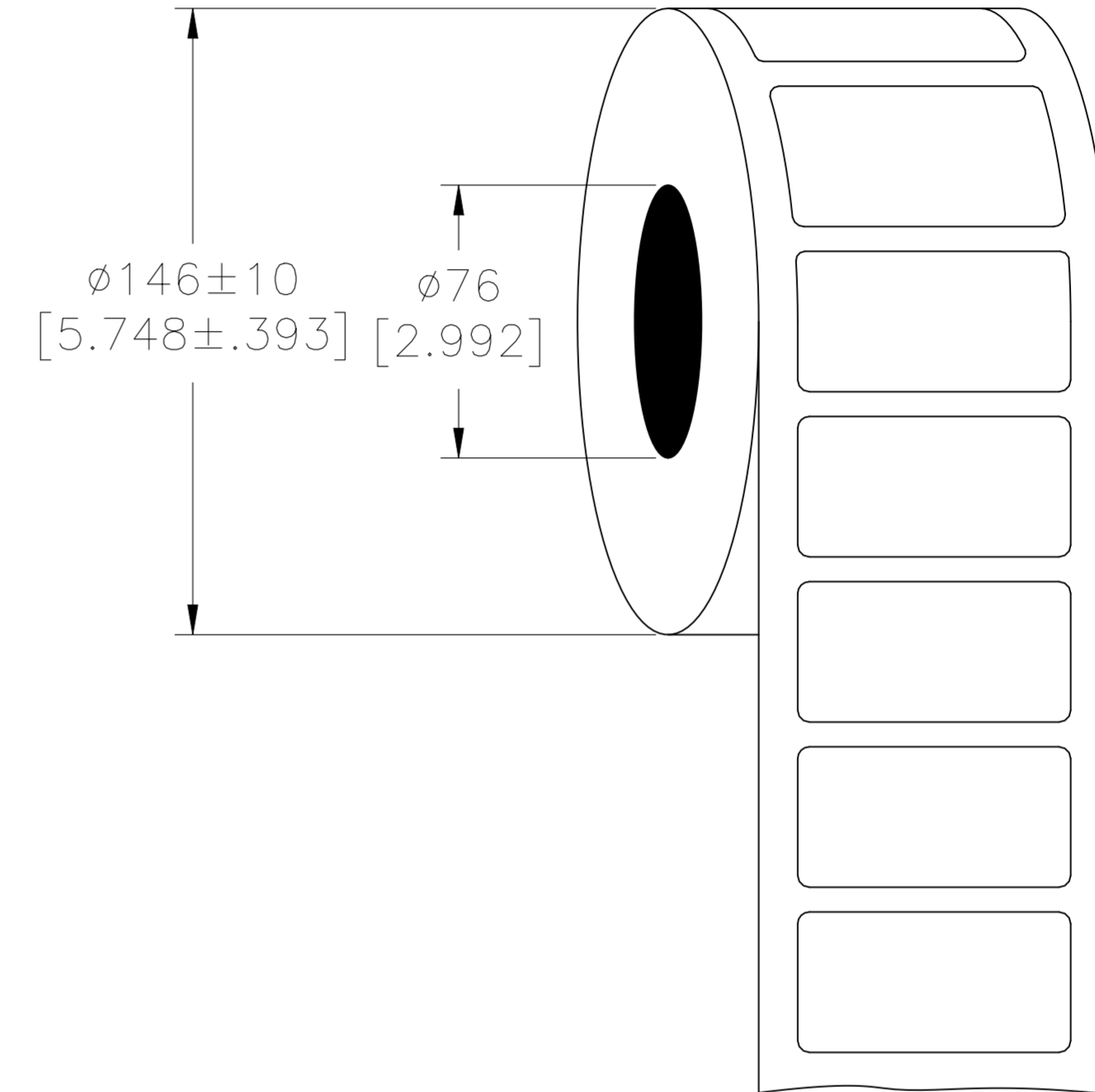

**OUTSIDE WOUND
LABEL ACROSS: 1
PER ROLL QTY: 625**

All dimensions in mm [Inch]

TE PN: 1SET530207R0000

UL-MARKING AND LABELLING SYSTEMS		
PGJ12 - Printing Materials - Component (UL 969)		
PGJ18 - Printing Materials Certified for Canada - Component (CSA C22.2 No. 0.15)		
File: MH17292	Product design: PL-9	Ribbon: 411-121005

TOLERANCES mm [INCH]	
LABEL HEIGHT:	± 0.3 [.012]
LABEL WIDTH:	± 0.3 [.012]
WEB WIDTH:	± 0.5 [.020]
VERTICAL REPEAT:	± 0.5 [.020]*
HORIZONTAL REPEAT:	± 0.5 [.020]*
LABEL POSITIONING:	± 0.5 [.020]*
LEFT MARGIN:	± 0.5 [.020]
QUANTITY:	-0 % +2 %
*NON ACCUMULATING	

DIMENSIONS:		TOLERANCES UNLESS OTHERWISE SPECIFIED:	
mm [INCHES]		mm [INCHES]	
	0 PLC	\pm	
	1 PLC	\pm	
	2 PLC	\pm	
	3 PLC	\pm	
	4 PLC	\pm	
	ANGLES	\pm	
MATERIAL	SEE TABLE	FINISH	GLOSSY

MATERIAL	POLYESTER WHITE GLOSS		
ADHESIVE TYPE	ACRYLIC PE FOAM		
LINEAR	BROWN KRAFT		
DWN	GOPALAKRISHNA HV	TE Connectivity	
CHK	D.BURGAT	TE Connectivity	
APVD	D.BURGAT	TE Connectivity	
PRODUCT SPEC	TTDS-285	PANEL LABEL-WHITE	
APPLICATION SPEC		35.0 x 18.0mm [1.378 x 0.709inch]	
WEIGHT	0.297g	SIZE	A2
CUSTOMER DRAWING		CAGE CODE	FB1U7
		DRAWING NO	C=PLE-035018-WH-0.625
		RESTRICTED TO	
		SCALE	NTS
		SHEET	1 of 1
		REV	A