

P	LTR	DESCRIPTION	DATE	DWN	APVD
A		NEW DRAWING	09JUN2022	GK	DB

### LABEL AND LINER DESIGN

### PRESENTATION

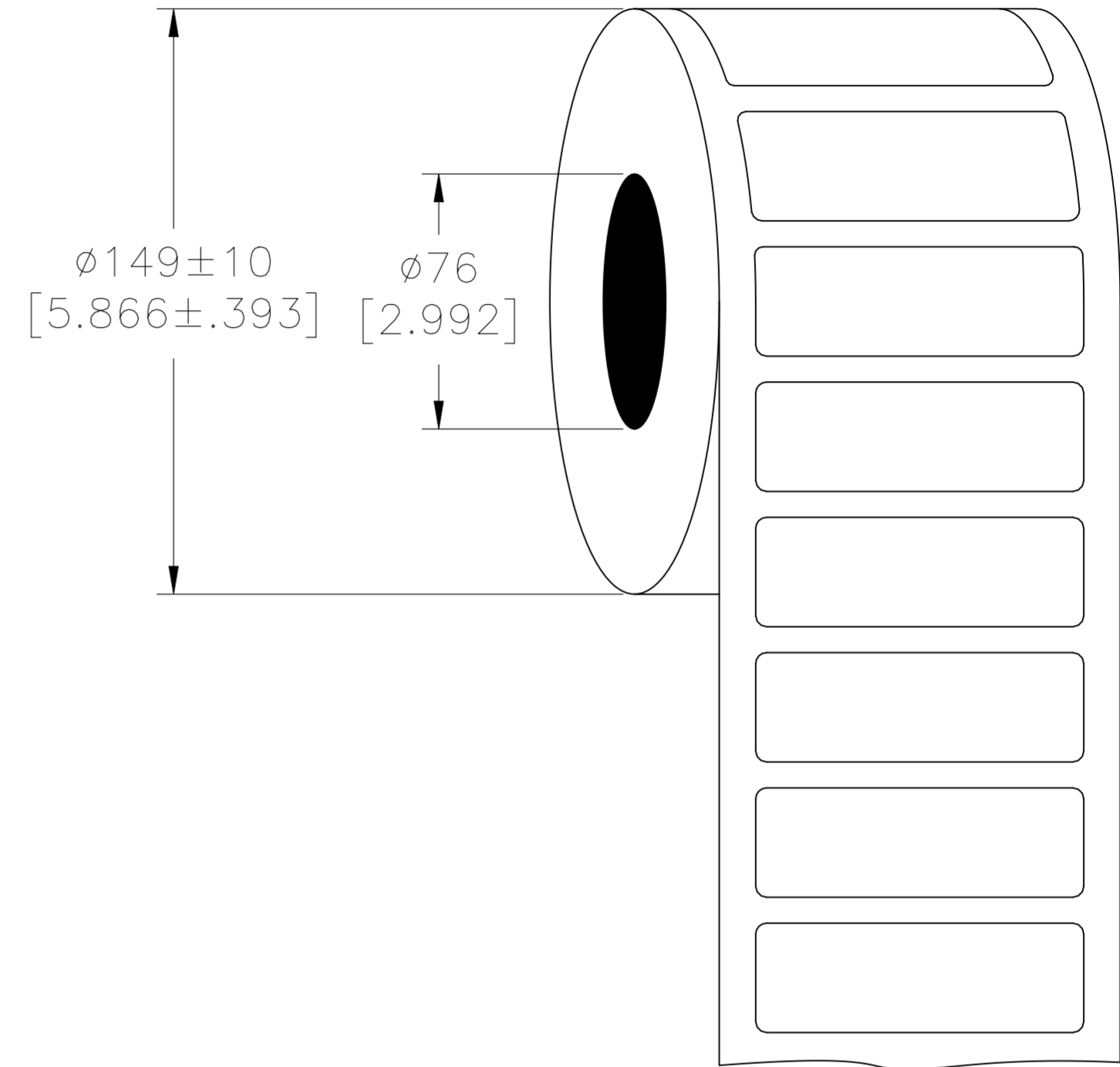
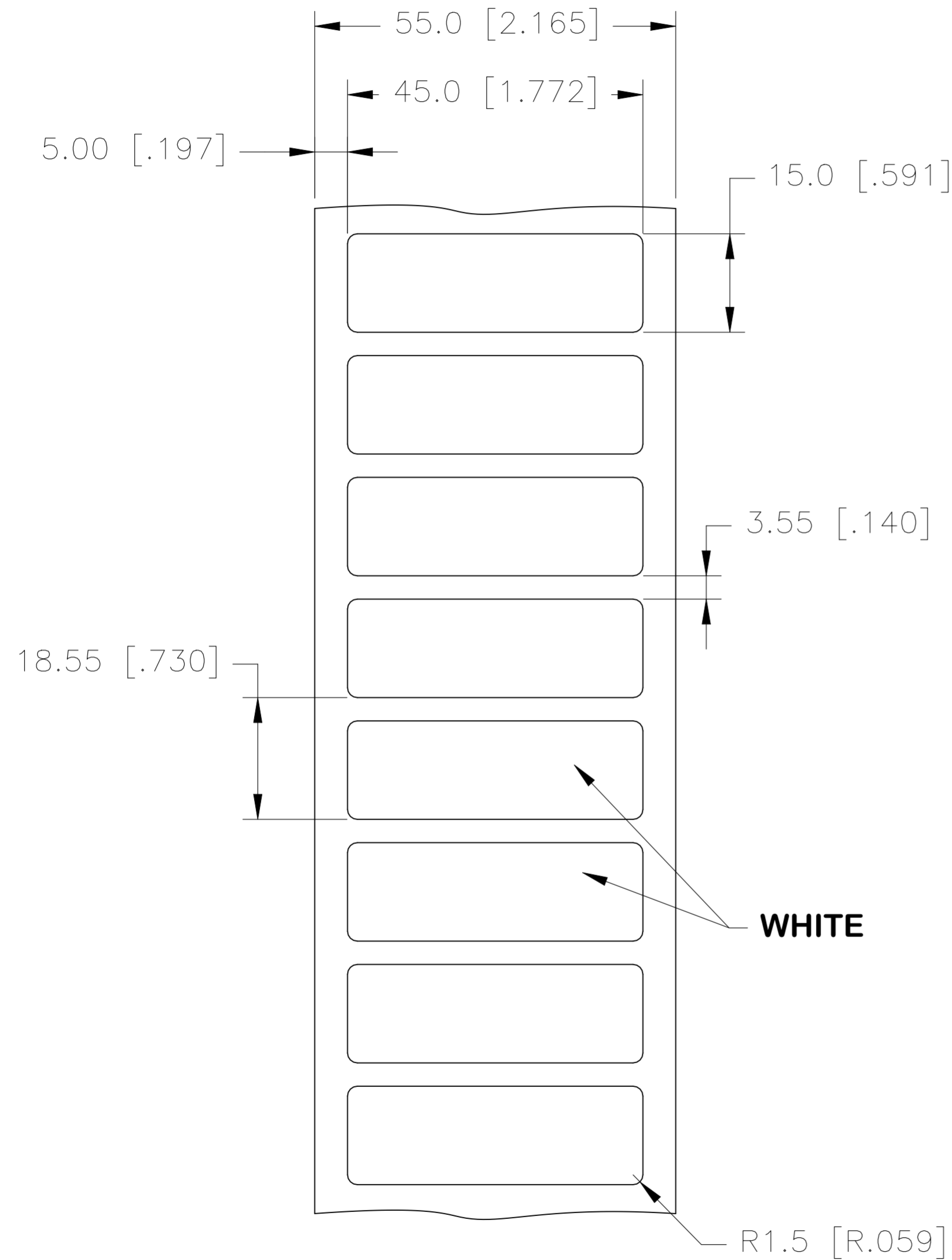

**OUTSIDE WOUND  
LABEL ACROSS: 1  
PER ROLL QTY: 750**

All dimensions in mm [Inch]

**TE PN: 1SET530209R0000**

UL-MARKING AND LABELLING SYSTEMS		
PGJ12 - Printing Materials - Component (UL 969)		
PGJ18 - Printing Materials Certified for Canada - Component (CSA C22.2 No. 0.15)		
File: MH17292	Product design: <b>PL-9</b>	Ribbon: 411-121005

TOLERANCES mm [INCH]	
LABEL HEIGHT:	$\pm 0.3$ [.012]
LABEL WIDTH:	$\pm 0.3$ [.012]
WEB WIDTH:	$\pm 0.5$ [.020]
VERTICAL REPEAT:	$\pm 0.5$ [.020]*
HORIZONTAL REPEAT:	$\pm 0.5$ [.020]*
LABEL POSITIONING:	$\pm 0.5$ [.020]*
LEFT MARGIN:	$\pm 0.5$ [.020]
QUANTITY:	-0 % +2 %
*NON ACCUMULATING	

DIMENSIONS:		TOLERANCES UNLESS OTHERWISE SPECIFIED:	
mm [INCHES]			
		0 PLC	$\pm$
		1 PLC	$\pm$
		2 PLC	$\pm$
		3 PLC	$\pm$
		4 PLC	$\pm$
		ANGLES	$\pm$
MATERIAL	SEE TABLE	FINISH	GLOSSY

MATERIAL	POLYESTER WHITE GLOSS	
ADHESIVE TYPE	ACRYLIC PE FOAM	
LINEAR	BROWN KRAFT	
DWN	GOPALAKRISHNA HV	
CHK	D.BURGAT	
APVD	D.BURGAT	
PRODUCT SPEC	TTDS-285	
APPLICATION SPEC		
NAME	PANEL LABEL-WHITE	
SIZE	45.0 x 15.0mm [1.772 x 0.591inch]	
CAGE CODE	A2 FB1U7	
DRAWING NO	C=PLE-045015-WH-0.75	
RESTRICTED TO		
WEIGHT	0.318g	
CUSTOMER DRAWING	SCALE NTS	
SHEET	1 of 1	
REV	A	