

1

2

3

4

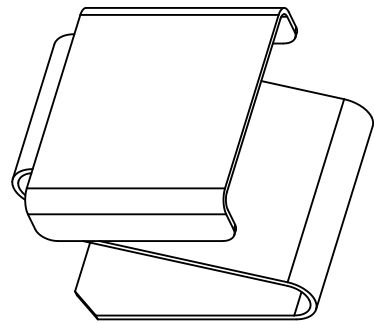

3D VIEW.

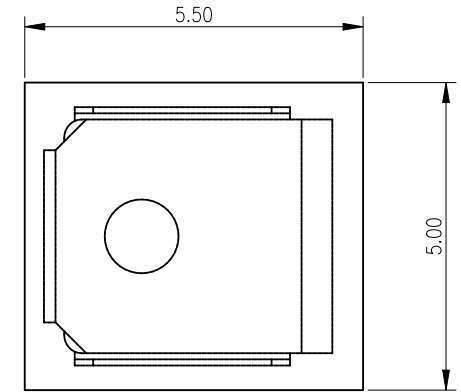
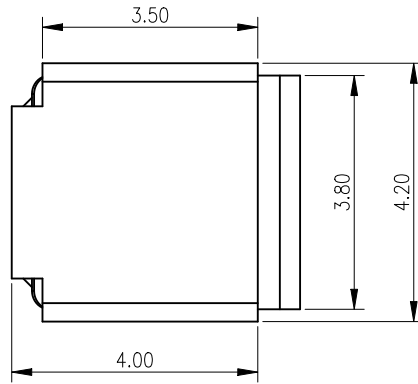

P.C.B LAYOUT:TOL±0.10

REV.	ECR/ECN No.	DESCRIPTION	DRAWN/DATE	CHECKED/DATE	APPROVED/DATE
A		NEW RELEASE	Kun Chen 2015-11-18	Bing Ye 2015-11-18	Qi Han 2015-11-18
B	ECN2022112	UPDATE FRAME	Abner 2022-07-20	Staven 2022-07-20	Sam 2022-07-20

A

A

B

B

C

C

D

D

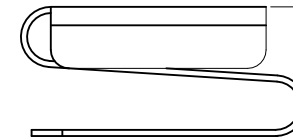
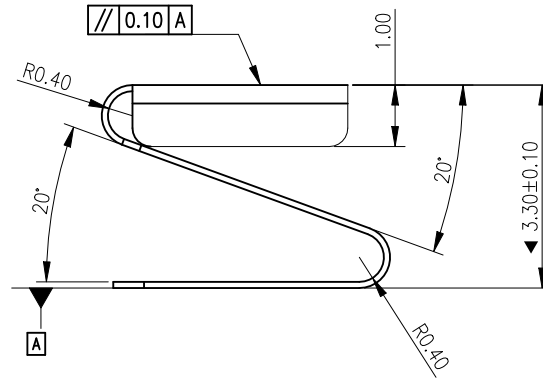
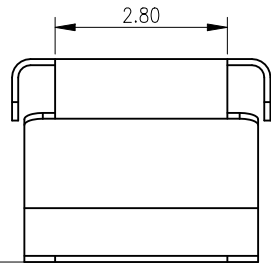

Recommended pressing stroke

Working position: 1.2 MAX

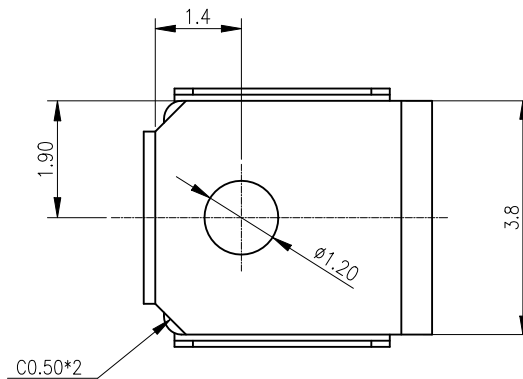

NOTES:

1. MATERIAL: SUS 304-H T=0.10mm;
2. BURR: 0.03mm MAX.
3. PLATING: GOLD FLASH SURFACE PLATING OVER CONTACT AREAS, GOLD FLASH SURFACE PLATING OVER SOLDER AREAS, Ni 40-120u" UNDER PLATING OVER ALL.
4. ALL MATERIAL MUST BE COMPLY WITH RoHS2.0

UNLESS OTHERWISE SPECIFIED TOLERANCES				ANGLE OF PROJECTION		Amphenol AORORA	
X.	±0.30	X. *	± 5'			Amphenol Aorora Technology (Huizhou) Co.,Ltd	
X.X	±0.25	X.X *	± 4'				
X.XX	±0.20	X.XX *	± 3'	DOC TYPE: Customer Drw		TITLE: SPRING H3.3	
X.XXX	±0.15	X.XXX *	± 2'	DRAWN DATE: Abner 2022-07-20	SIZE: A4		
LINEAR DIMS		ANGLES DIMS		DESIGN DATE: Abner 2022-07-20	PART NUMBER: Z01B-4G7L1-11000-E000		
DWG NO.: A-S0334				CHECKED DATE: Staven 2022-07-20	REV. B		
MATERIAL: SEE NOTES				APPROVED DATE: Sam 2022-07-20	SCALE: 1:1		UNIT: mm
FINISHED: SEE NOTES				SHEET 1 OF 1			

1

2

3

4

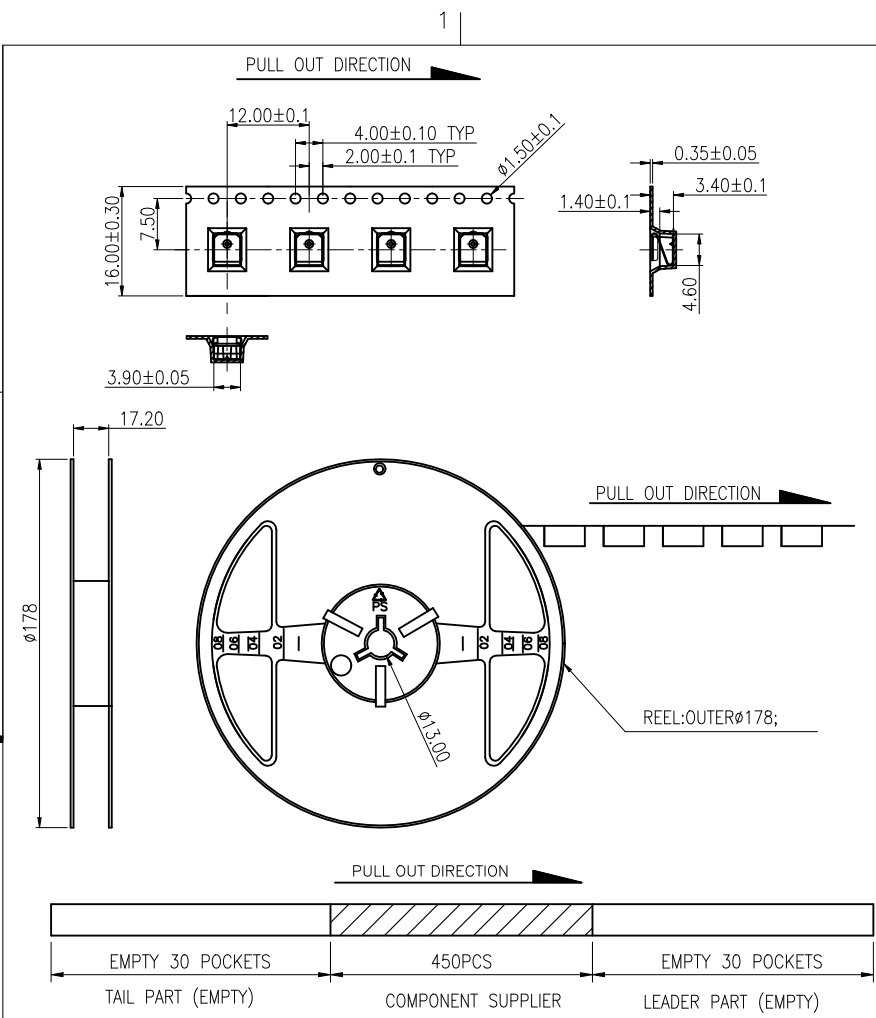

- NOTES:
- MATERIAL:
    - CARRY TAPE: HIPS, T=0.35mm, CLEAR
    - REEL: HIPS, BLUE.
    - SHIM: PE, CLEAR.
  - PRIMARY PACKING: 450PCS/REEL.
  - SECONDARY PACKING: "15" REELS/CARTON ("TOTAL"=15\*450/CARTON).
  - PEELING RESISTANCE: 0.1N~0.9N(10~90gf);  
PEELING ANGLE: 165°~180°;  
PEELING SPEED: 300mm/minutes.

PRODUCT	PCS/REEL	inside BOX (TOL:PCS)	outside BOX (TOL:PCS)
Z型端子	450PCS	15REEL(6750PCS)	4 BOX (27000PCS)

REV.	ECR/ECN No.	DESCRIPTION	DRAWN/DATE	CHECKED/DATE	APPROVED/DATE
B		Update package quantity	Staven 2016-08-08	MuYuan Liu 2016-08-08	HongKui Liu 2016-08-08
C	ECN2022112	UPDATE FRAME	Abner 2022-07-20	Staven 2022-07-20	Sam 2022-07-20

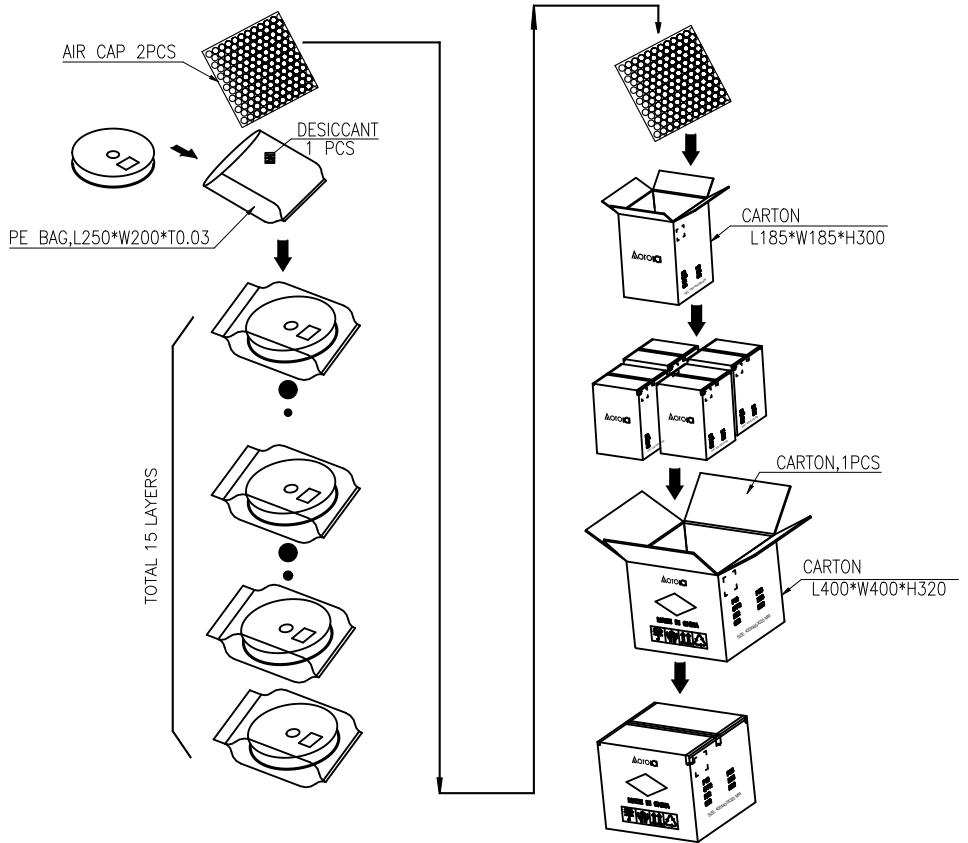

UNLESS OTHERWISE SPECIFIED TOLERANCES				ANGLE OF PROJECTION		Amphenol AORORA	
X.	±0.15	X. °	± 1'			Amphenol Aorora Technology (Huizhou) Co.,Ltd	
X.X	±0.16	X.X °	± 0.5'				
X.XX	±0.05	X.XX °	± 0.5'	DOC TYPE		TITLE:	
X.XXX	±0.03	X.XXX °	± 1'	PACKING DWG.		SPRING H3.3	
LINEAR DIMS	ANGLES DIMS		DRAWN	DATE	Abner	2022-07-20	PART NUMBER: Z01B-4G7L1-11000-E000
DWG NO.:	A-H0183		DESIGN	DATE	Abner	2022-07-20	
MATERIAL	SEE NOTES		CHECKED	DATE	Staven	2022-07-20	
FINISHED	SEE NOTES		APPROVED	DATE	Sam	2022-07-20	
SIZE	A4		SCALE	1:1		UNIT : mm	SHEET 1 OF 1
REV.	C						