

REV.	ECR/ECN No.	DESCRIPTION	DRAWN/DATE	CHECKED/DATE	APPROVED/DATE
F		UPDATE FRAME	Staven 2020-11-13	Staven 2020-11-13	Biao 2020-11-13
G	ECN2022112	UPDATE CPK SYMBOLS	Abner 2022-07-20	Staven 2022-07-20	Sam 2022-07-20

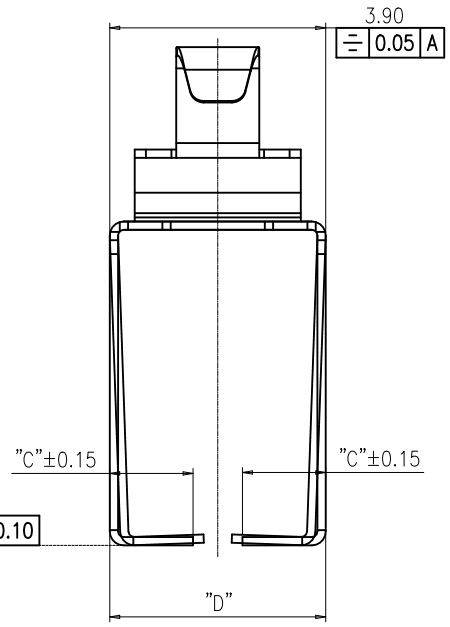
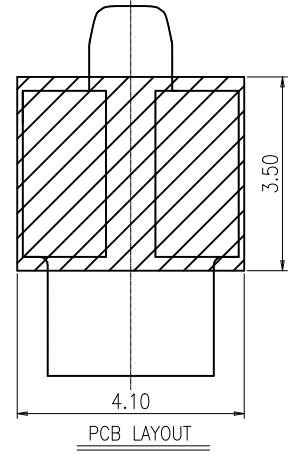
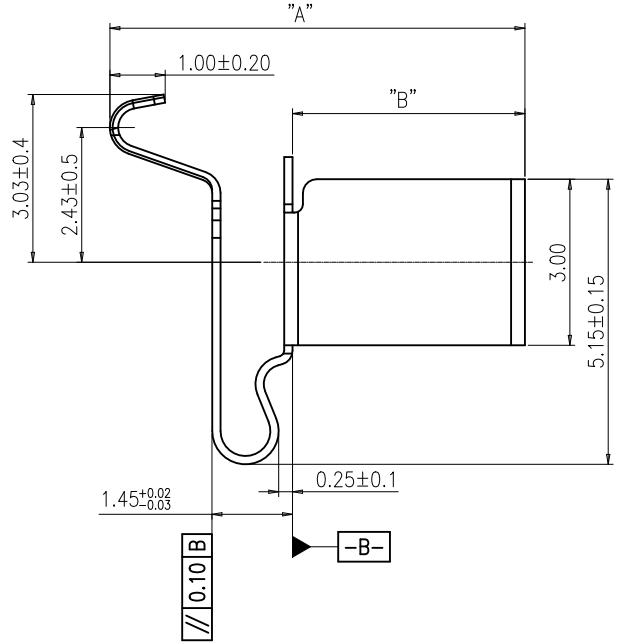
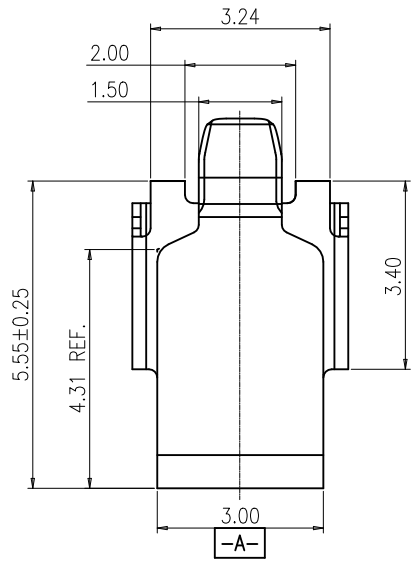

- NOTES:
- 1、 MATERIAL: SUS 304-H T=0.15mm;
  - 2、 ALLOW BURR 0.03mm Max.;
  - 3、 PLATING: Au 2u" SURFACE PLATING OVER CONTACT AREAS, Au 2u" SURFACE PLATING OVER SOLDER AREAS, Ni 40-120u" UNDER PLATING OVER ALL.
  - 4、 "▼" THE SYMBOL IS REPRESENTED AS CPK AND  $\bar{X}$ -R.

TABLE:

PART NUMBER	A	B	C	D
Z00D-4G7L1-11000	4.8 <sup>+0.3</sup> <sub>-0.05</sub>	1.5 <sup>+0.0</sup> <sub>-0.3</sub>	1.50	3.90 <sup>+0</sup> <sub>-0.20</sub>
Z007-4G7L1-11000	5.2 <sup>+0.3</sup> <sub>-0.05</sub>	1.9 <sup>+0.0</sup> <sub>-0.3</sub>	1.05	3.90 <sup>+0</sup> <sub>-0.20</sub>
Z00C-4G7L1-11000	7.5 <sup>+0.3</sup> <sub>-0.05</sub>	4.2 <sup>+0.0</sup> <sub>-0.3</sub>	1.50	3.90 <sup>+0</sup> <sub>-0.20</sub>
Z00F-4G7L1-11000	9.0 <sup>+0.3</sup> <sub>-0.05</sub>	5.7 <sup>+0.0</sup> <sub>-0.3</sub>	0.80	3.90 <sup>+0</sup> <sub>-0.5</sub>
Z00N-4G7L1-11000	6.3 <sup>+0.3</sup> <sub>-0.3</sub>	3.0±0.15	1.50	3.90±0.15
Z00E-4G7L1-11000	4.0 <sup>+0.3</sup> <sub>-0.3</sub>	0.7±0.15	1.50	3.90±0.15
Z00X-4G7L1-11000-E000	5.6 <sup>+0.3</sup> <sub>-0.3</sub>	2.3±0.15	1.50	3.90±0.15

UNLESS OTHERWISE SPECIFIED TOLERANCES		ANGLE OF PROJECTION		 Amphenol Aorora Technology (Huizhou) Co.,Ltd	
X.	±0.30	X. *	± 5'		
X.X	±0.25	X.X *	± 4'	DOC TYP Customer Drw	
X.XX	±0.20	X.XX *	± 3'		
X.XXX	±0.15	X.XXX *	± 2'	DRAWN DATE Abner 2022-07-20	
LINEAR DIMS		ANGLES DIMS			
DWG NO.: A-S0198		DESIGN DATE Abner 2022-07-20		TITLE: SPRING	
MATERIAL SEE NOTES		CHECKED DATE Staven 2022-07-20			
FINISHED SEE NOTES		APPROVED DATE Sam 2022-07-20		SIZE A4	PART NUMBER: SEE TABLE
				SCALE 1:1	UNIT : mm
				SHEET 1 OF 1	



This document is the property of and embodies CONFIDENTIAL and PROPRIETARY information of AOR. No part of the information shown on this document may be used in any way or disclosed to others without the written consent of AOR. © 2019 AOR

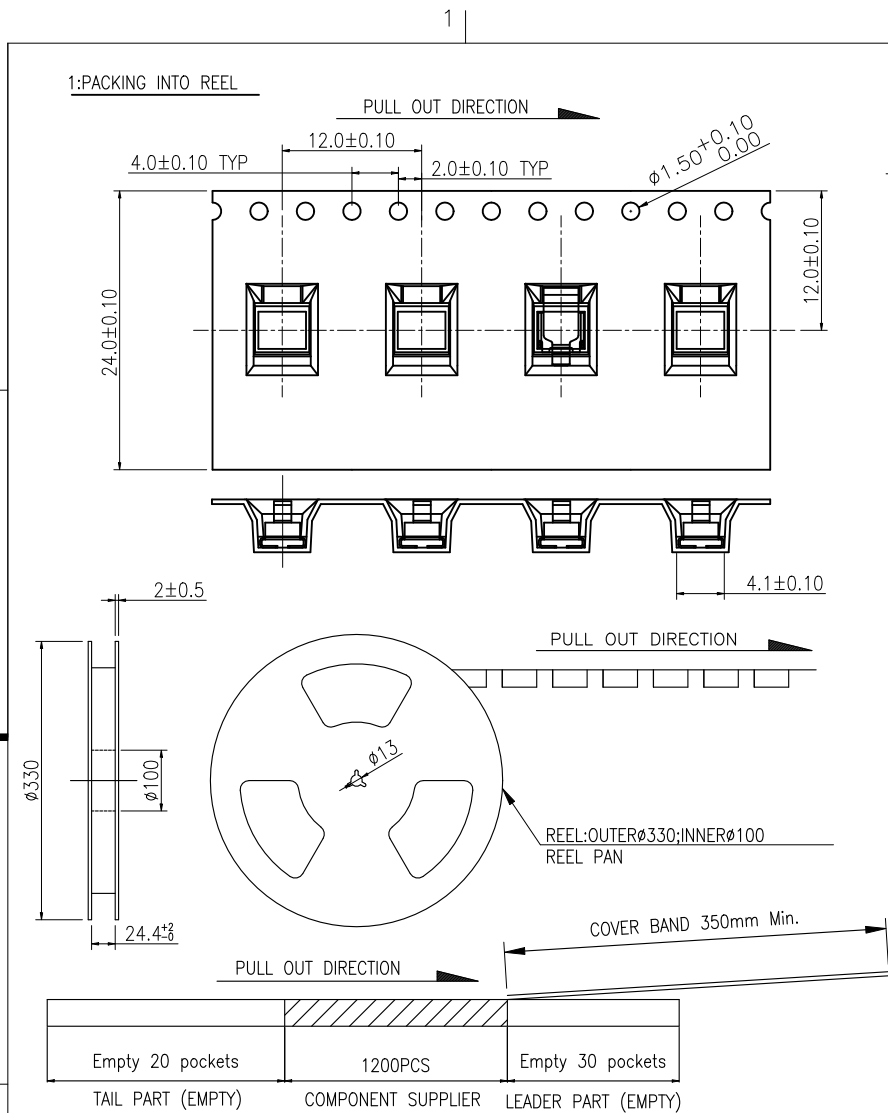

**NOTES:**

1. MATERIAL:
  - 1.1 CARRY TAPE:HIPS,T=0.40mm,COLOR:TRANSPARENT.
  - 1.2 REEL:HIPS,BLUE.
  - 1.3 SHIM:PE,CLEAR.
2. PRIMARY PACKING:1200PCS/REEL.
3. SECONDARY PACKING:10 REELS/CARTON  
("TOTAL"=10\*1200/CARTON).
4. PEELING RESISTANCE: 0.1N~0.9N(10~90gf);  
PEELING ANGLE: 165°~180°;  
PEELING SPEED: 300mm/minutes.

REV.	ECR/ECN No.	DESCRIPTION	DRAWN/DATE	CHECKED/DATE	APPROVED/DATE
C		ADD PART NUMBER	Staven 2017-03-14	MuYuan Liu 2017-03-14	Judy 2017-03-14
D	ECN2022112	UPDATE FRAME	Abner 2022-07-20	Staven 2022-07-20	Sam 2022-07-20

TABLE:

PART NO.	PCS/REEL	N REEL/BOX (TOL PCS)
Z00E-4G7L1-11000	1200	10REEL/BOX (12000pcs)
Z01N-4G7L1-11000-E000		

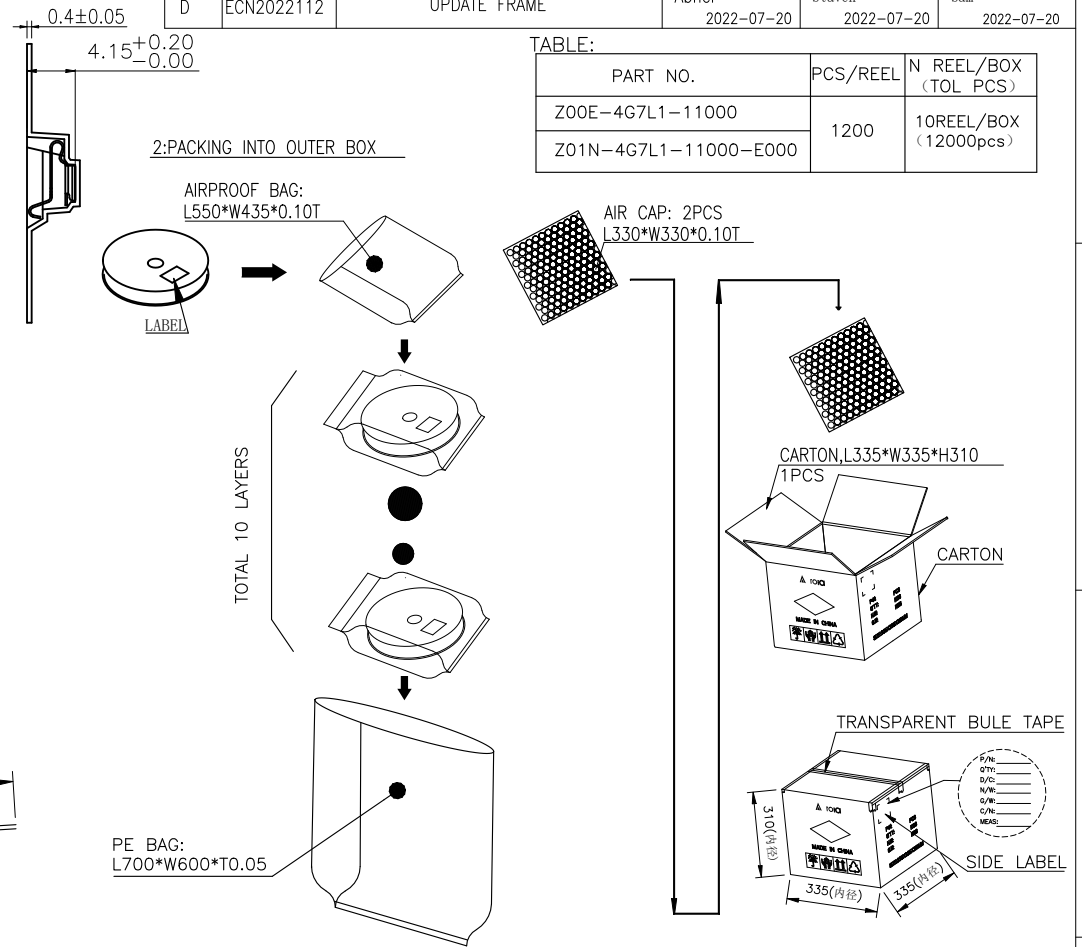

UNLESS OTHERWISE SPECIFIED TOLERANCES				ANGLE OF PROJECTION		Amphenol AORORA			
X.	±0.15	X. °	± 1'			Amphenol Aorora Technology (Huizhou) Co.,Ltd			
X.X	±0.16	X.X °	± 0.5'						
X.XX	±0.05	X.XX °	± 0.5'	DOC TYPE		TITLE:			
X.XXX	±0.03	X.XXX °	± 1'	PACKING DWG.		SPRING H4.0			
LINEAR DIMS	ANGLES DIMS		DRAWN	DATE	Abner	2022-07-20	SIZE		
DWG NO.:	A-H0058		DESIGN	DATE	Abner	2022-07-20		PART NUMBER: SEE TABLE	
MATERIAL	SEE NOTES		CHECKED	DATE	Staven	2022-07-20			REV. D
FINISHED	SEE NOTES		APPROVED	DATE	Sam	2022-07-20			
SCALE	1:1	UNIT : mm	SHEET	1 OF 1					