

1

2

3

4

REV.	ECR/ECN No.	DESCRIPTION	DRAWN/DATE	CHECKED/DATE	APPROVED/DATE
F		UPDATE FRAME	Staven 2020-11-13	Staven 2020-11-13	Biao 2020-11-13
G	ECN2022112	UPDATE CPK SYMBOLS	Abner 2022-07-20	Staven 2022-07-20	Sam 2022-07-20

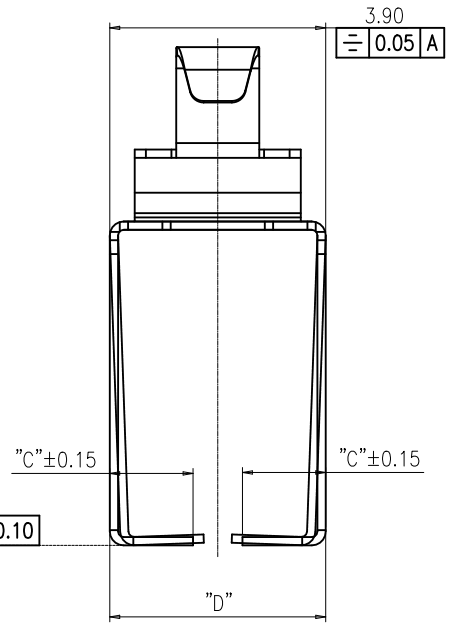
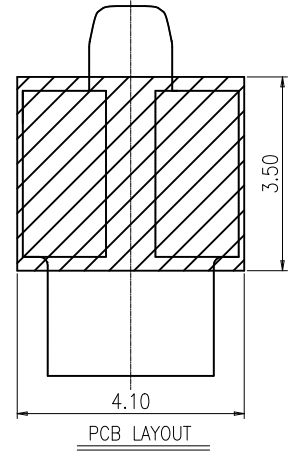
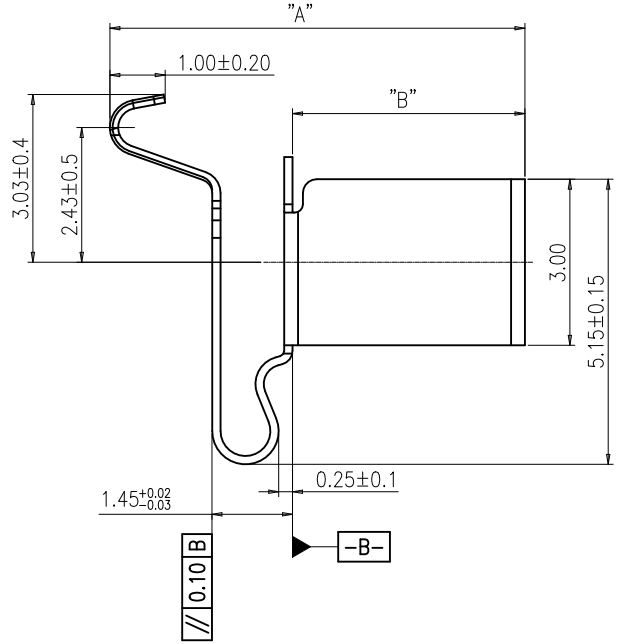
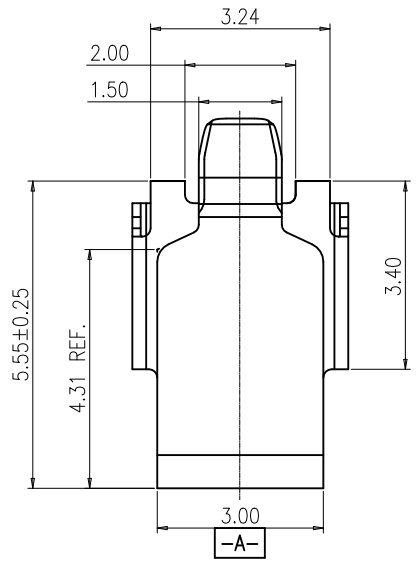

- NOTES:
- 1、 MATERIAL: SUS 304-H T=0.15mm;
 - 2、 ALLOW BURR 0.03mm Max.;
 - 3、 PLATING: Au 2u" SURFACE PLATING OVER CONTACT AREAS, Au 2u" SURFACE PLATING OVER SOLDER AREAS, Ni 40-120u" UNDER PLATING OVER ALL.
 - 4、 "▼" THE SYMBOL IS REPRESENTED AS CPK AND \bar{X} -R.

TABLE:

PART NUMBER	A	B	C	D
Z00D-4G7L1-11000	4.8 ^{+0.3} _{-0.05}	1.5 ^{+0.0} _{-0.3}	1.50	3.90 ⁺⁰ _{-0.20}
Z007-4G7L1-11000	5.2 ^{+0.3} _{-0.05}	1.9 ^{+0.0} _{-0.3}	1.05	3.90 ⁺⁰ _{-0.20}
Z00C-4G7L1-11000	7.5 ^{+0.3} _{-0.05}	4.2 ^{+0.0} _{-0.3}	1.50	3.90 ⁺⁰ _{-0.20}
Z00F-4G7L1-11000	9.0 ^{+0.3} _{-0.05}	5.7 ^{+0.0} _{-0.3}	0.80	3.90 ⁺⁰ _{-0.5}
Z00N-4G7L1-11000	6.3 ^{+0.3} _{-0.3}	3.0±0.15	1.50	3.90±0.15
Z00E-4G7L1-11000	4.0 ^{+0.3} _{-0.3}	0.7±0.15	1.50	3.90±0.15
Z00X-4G7L1-11000-E000	5.6 ^{+0.3} _{-0.3}	2.3±0.15	1.50	3.90±0.15

UNLESS OTHERWISE SPECIFIED TOLERANCES		ANGLE OF PROJECTION		 Amphenol Aorora Technology (Huizhou) Co.,Ltd	
X.	±0.30	X.	± 5'		
X.X	±0.25	X.X	± 4'	TITLE: SPRING	
X.XX	±0.20	X.XX	± 3'	DRAWN DATE: Abner 2022-07-20	
X.XXX	±0.15	X.XXX	± 2'	DESIGN DATE: Abner 2022-07-20	
LINEAR DIMS		ANGLES DIMS		CHECKED DATE: Staven 2022-07-20	
DWG NO.: A-S0198		APPROVED DATE: Sam 2022-07-20		SIZE: A4	
MATERIAL	SEE NOTES	PART NUMBER: SEE TABLE		REV. G	
FINISHED	SEE NOTES	SCALE: 1:1	UNIT: mm	SHEET 1 OF 1	

This document is the property of and embodies CONFIDENTIAL and PROPRIETARY information of AOR. No part of the information shown on this document may be used in any way or disclosed to others without the written consent of AOR. © 2019 AOR

1

2

3

4

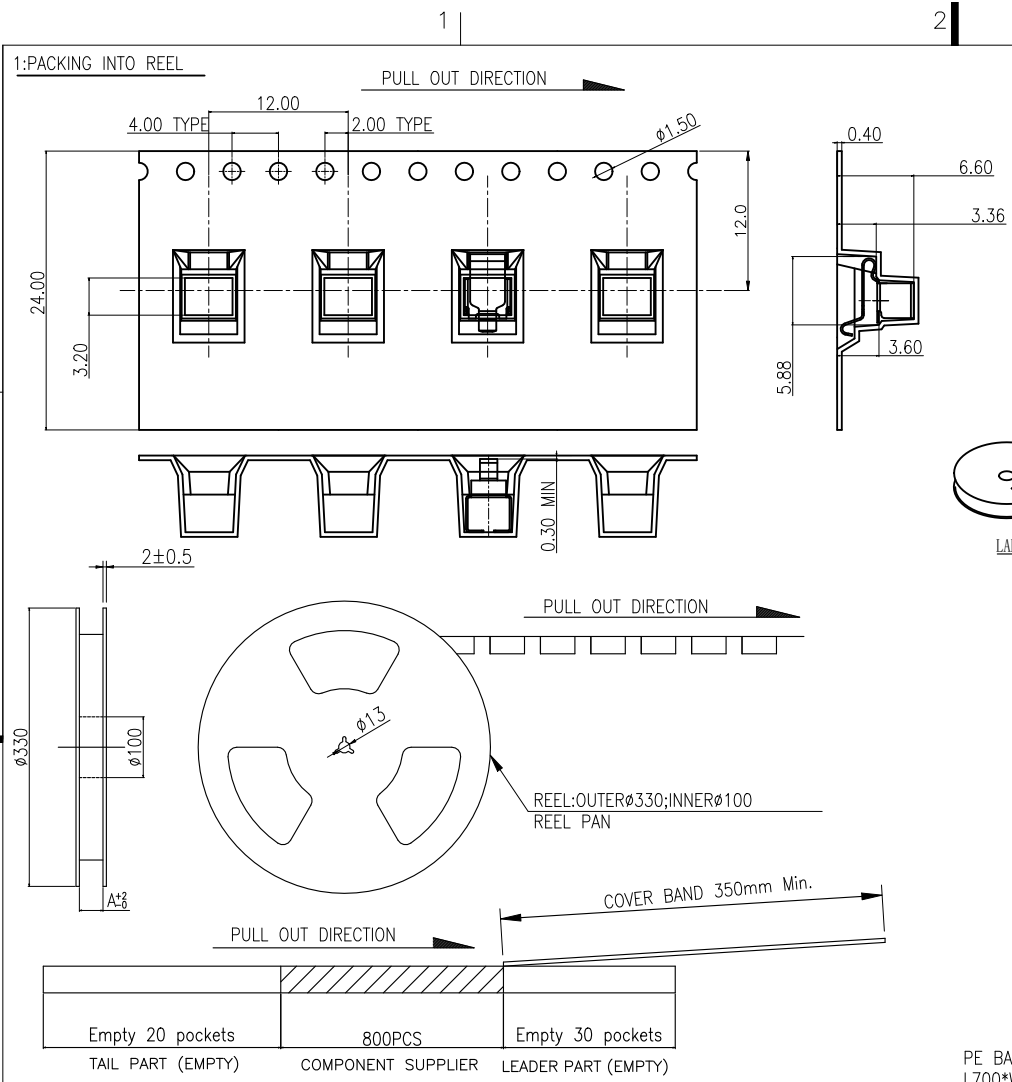

REV.	ECR/ECN No.	DESCRIPTION	DRAWN/DATE	CHECKED/DATE	APPROVED/DATE
B		Add PE bag specification	Staven 2017-03-14	MuYuan Liu 2017-03-14	Judy 2017-03-14
C	ECN2022112	UPDATE FRAME	Abner 2022-07-20	Staven 2022-07-20	Sam 2022-07-20

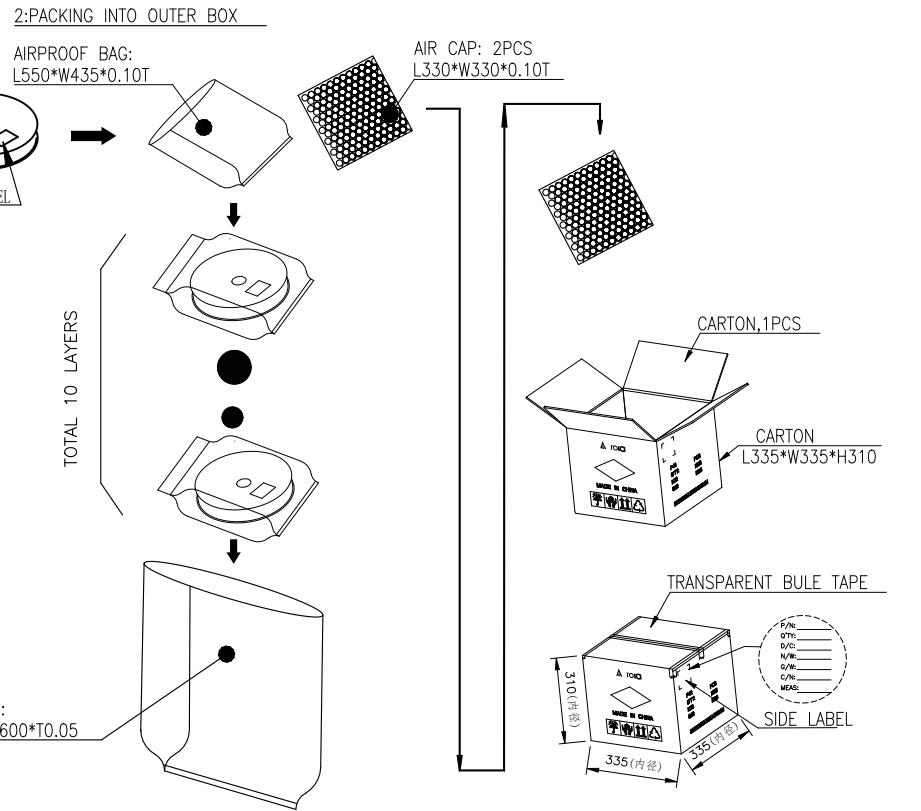

- NOTES:
- MATERIAL:
 - CARRY TAPE:HIPS,T=0.40mm,COLOR:TRANSPARENT.
 - REEL:HIPS,BLUE.
 - SHIM:PE,CLEAR.
 - PRIMARY PACKING:800PCS/REEL.
 - SECONDARY PACKING:10 REELS/CARTON
("TOTAL"=10*800/CARTON).
 - PEELING RESISTANCE: 0.1N~0.9N(10~90gf);
PEELING ANGLE: 165°~180°;
PEELING SPEED: 300mm/minutes.

NO. OF POS	PCS/REEL	N REEL/BOX (TOL PCS)
H6.3	800	10REEL/BOX (8000pcs)

UNLESS OTHERWISE SPECIFIED TOLERANCES				ANGLE OF PROJECTION	
X.	±0.15	X. *	± 1'		
X.X	±0.16	X.X *	± 0.5'		
X.XX	±0.05	X.XX *	± 0.5'	DOC TYPE	
X.XXX	±0.03	X.XXX *	± 1'		
LINEAR DIMS	ANGLES DIMS			DRAWN DATE	
DWG NO.:	A-H0159			Abner 2022-07-20	
MATERIAL	SEE NOTES			DESIGN DATE	
FINISHED	SEE NOTES			Abner 2022-07-20	
				CHECKED DATE	
				Staven 2022-07-20	
				APPROVED DATE	
				Sam 2022-07-20	

Amphenol AORORA
Amphenol Aorora Technology (Huizhou) Co.,Ltd

PACKING DWG. TITLE: SPRING H6.3

SIZE: A4 PART NUMBER: Z00N-4G7L1-11000 REV. C

SCALE: 1:1 UNIT: mm SHEET 1 OF 1