

Connector A: SMA Jack (Female Socket)				
Connector B: SMA Jack (Female Socket)				
Body Style	Bulkhead Mount			
	Connector A		Connector B	
Connector Part	Material	Finish	Material	Finish
Body	Brass	Gold	Brass	Gold
Center Contact	BeCu	Gold	BeCu	Gold
Insulator	PTFE	-	PTFE	-
	Material		Finish	
Washer	Brass		Gold	
Nut	Brass		Gold	

REVISIONS			
REV	DESCRIPTION	DATE	APPV
A	INITIAL RELEASE OF LINX INTERNAL DRAWING	13-DEC-19	SAH

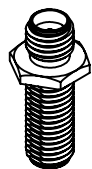
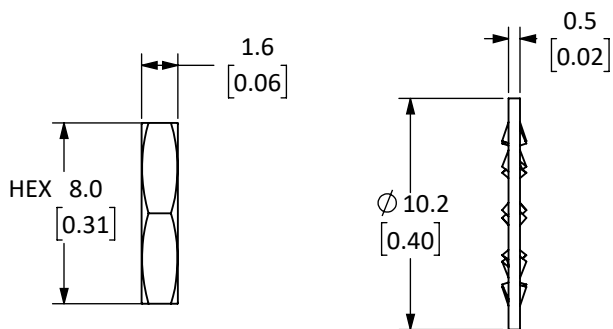
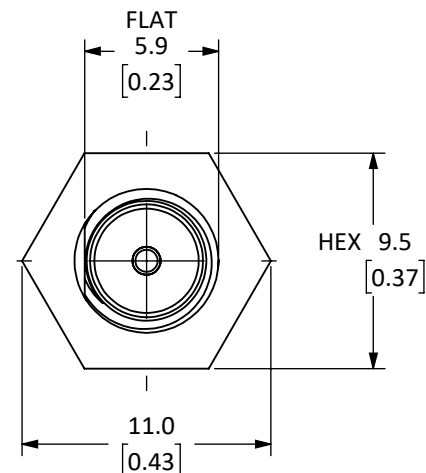
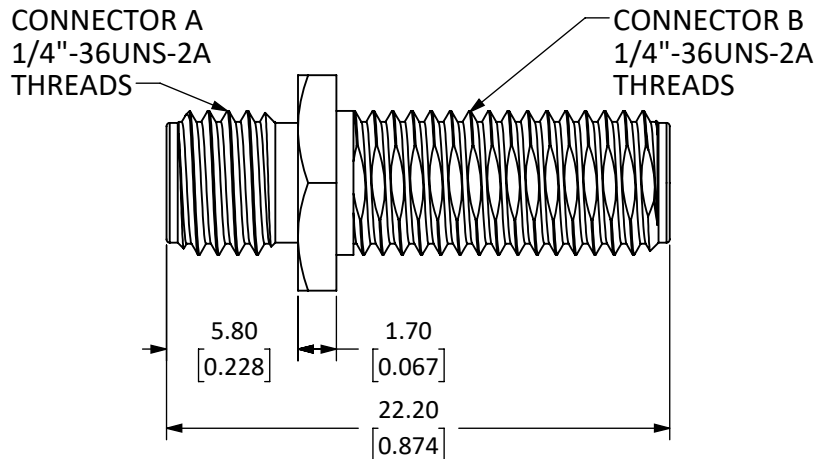

NUT

WASHER

SCALE 1 : 1

NOTES: (UNLESS OTHERWISE SPECIFIED)

1. ALL DIMENSIONS ARE IN MILLIMETERS [INCHES].
2. DIMENSIONS APPLY AFTER FINISHING.
3. MANUFACTURE TO BE COMPLIANT WITH EU RoHS DIRECTIVE, USE MATERIALS THAT DO NOT CONTAIN REACH SUBSTANCES OF VERY HIGH CONCERN >1000ppm, AND USE DRC CONFLICT-FREE SOURCED MATERIALS.
4. SAFETY BREAK ALL SHARP CORNERS AND EDGES 0.5 MAXIMUM.
5. SEE TABLE I FOR ELECTRICAL SPECIFICATIONS. (SHEET 2)
6. SEE TABLE II FOR ENVIRONMENTAL SPECIFICATIONS. (SHEET 2)
7. SEE TABLE III FOR MECHANICAL SPECIFICATIONS. (SHEET 2)

WARNING: THIS DRAWING CONTAINS PROPRIETARY INFORMATION THAT IS THE SOLE PROPERTY OF LINX TECHNOLOGIES, AND SHALL BE TREATED AS SUCH. NO DISCLOSURE OR REPRODUCTION OF THIS DOCUMENT IS PERMITTED, IN WHOLE OR IN PART, WITHOUT THE EXPRESS WRITTEN PERMISSION OF LINX TECHNOLOGIES OR ITS DESIGNATED AGENTS.



159 ORT LANE
MERLIN, OR 97532

MATERIAL:	INTERPRET DIMENSIONS AND TOLERANCES PER ASME Y14.5. X ±2.0 ANGLES: ±1° .XX ±1.00 SURFACE: √ .XXX ±.500	PROJECTION:
FINISH:	DRAWN: B.MURPHY DT: 15-NOV-19	
	ENGR: D.VARATHARAJAN DT: 13-DEC-19	

TITLE: SMA FEMALE TO SMA FEMALE BULKHEAD MOUNT ADAPTER		
SIZE	DWG. NO.	REV
A	C-ADP-SMAF-SMAF-B-G	A
SCALE: 3:1 DO NOT SCALE DRAWING		SHEET 1 OF 2

5 TABLE I

Electrical Data	Detail
Impedance	50 Ω
Frequency Range	0 to 18 GHz
Insulation Resistance	5000 M Ω Min
Voltage Rating	1000 V RMS
Contact Resistance	Center: 2.0 m Ω Max Outer: 2.0 m Ω Max
VSWR	1.25 Max

6 TABLE II

Environmental Data	Detail
Corrosion (Salt Spray)	MIL-STD-202 Method 101 Test Condition B
Thermal Shock	MIL-STD-202 Method 107 Test Condition B
Vibration	MIL-STD-202 Method 204 Test Condition D
Mechanical Shock	MIL-STD-202 Method 213 Test Condition I
Temperature Range	-65°C to +165°C
Environmental Compliance	ROHS

7 TABLE III

Mechanical Data	Detail
Mounting Type	Panel Mount, Surface Mount, Straight
Fastening Type	1/4"-36UNS Threaded Coupling
Recommended Torque	0.57 N.m (5 in.lbs)
Coupling Nut Retention	60 lbs Min
Connector Durability	500 Cycles Min
Weight	4.0 g (0.14 oz)

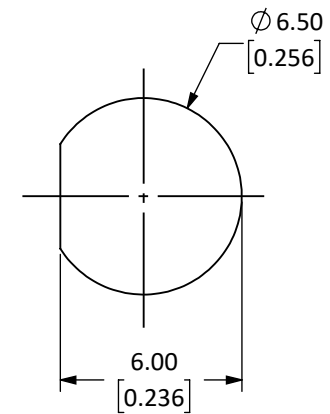
RECOMMENDED BULKHEAD
MOUNTING HOLE

SIZE	DWG. NO.	REV
A	ADP-SMAF-SMAF-B-G	A
SCALE: 4:1	DO NOT SCALE DRAWING	SHEET 2 OF 2