

REVISIONS			
REV	DESCRIPTION, ECN, EAR NO.	DATE	APP'D
D	PRODUCT DWG - EAR 15077	APR05/23	C.Z.
E	PRODUCT DWG - EAR 15077	JUN08/23	C.Z.

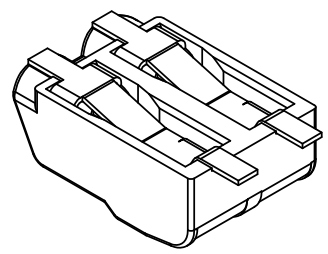

**GENERAL NOTES:**

- MATERIALS: ALL MATERIALS ARE RoHS COMPLIANT PER EU DIRECTIVE 2011/65/EU & AMENDMENTS.
  - HOUSING: LCP, WHITE.
  - CONTACTS: Cu ALLOY, TIN-PLATED.
- ELECTRICAL CHARACTERISTICS:
  - CURRENT RATING: 7A (18 AWG), 5A (20 AWG), 3A (22 AWG), 2A (24AWG), PER CONTACT.
  - VOLTAGE RATING: 250V.
  - INSULATION RESISTANCE: 500 MΩ MIN @ 500 VDC.
  - DIELECTRIC WITHSTANDING VOLTAGE: 1500 VAC FOR 1 MINUTE.
- OPERATING TEMPERATURE RANGE: -40°C TO +105°C.
- MECHANICAL CHARACTERISTICS:
  - DIRECT INSERTION OF SOLID WIRE OR STRANDED WIRE WITH TINNED END.
  - WIRE CROSS-SECTION: Ø1.10mm MAXIMUM, WITH INSULATION OD Ø2.40mm MAXIMUM.
  - WIRE RANGE:
    - 18 AWG SOLID.
    - 24-20 AWG SOLID & STRANDED WITH TINNED END.
- REFER TO PRODUCT SPEC S6222C AND APPLICATION SPEC S6236C FOR MORE DETAILS.

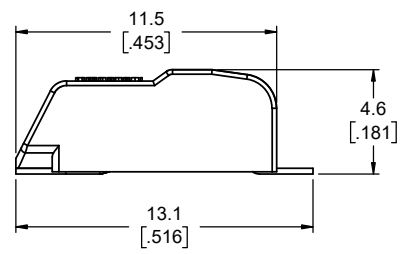
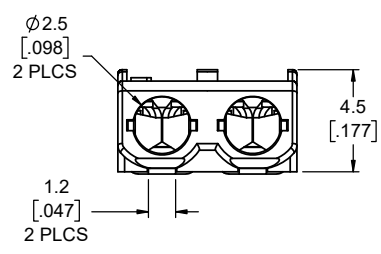
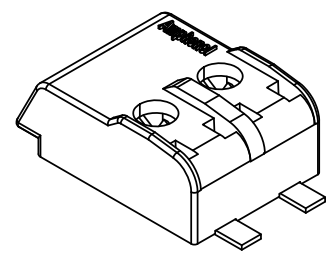
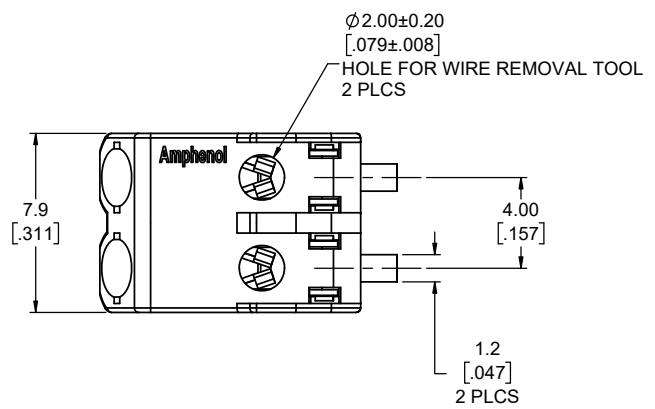

UNLESS SPECIFIED OTHERWISE	DRAWN	C. ZHANG	MAY05/22
PRIMARY UNITS MILLIMETRES	CHECKED		
SECONDARY INCHES	M.E. APP'D		
REFERENCE IN PARENTHESES	Q.A. APP'D		
GENERAL TOLERANCES	DWG APPR.	C. ZHANG	SEP07/22
1 DECIMAL PLACE ±0.30	ENG. REL. NO.	EAR 15077	
2 DECIMAL PLACES ±0.10	REF.		
3 DECIMAL PLACES	THIRD ANGLE PROJECTION		DO NOT SCALE DRAWING
ANGULAR DEGREES			

**Amphenol Canada Corp.**  
Commercial Products

**FLT SERIES, SMD  
TERMINAL BLOCK - 2 POLES  
RoHS COMPLIANT**

DWG. NO. **P-FLT-S22WR-00** REV **E**

CODE ID NO. 03554 DWG SIZE: X SCALE: 6:1 SHEET 1 OF 2

REVISIONS			
REV	DESCRIPTION, ECN, EAR NO.	DATE	APP'D
D	PRODUCT DWG - EAR 15077	APR05/23	C.Z.
E	PRODUCT DWG - EAR 15077	JUN08/23	C.Z.

**PCB LAYOUT:**

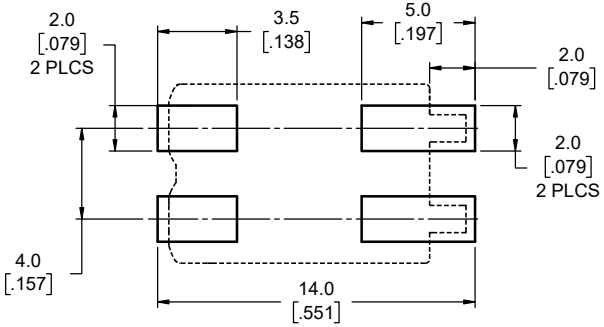

**PACKAGING:**

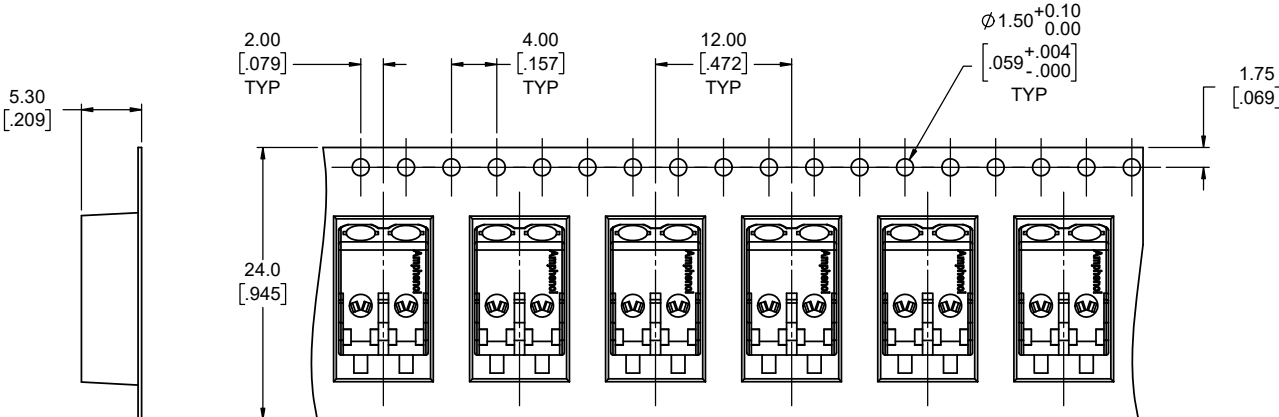

(SCALE 3:1)

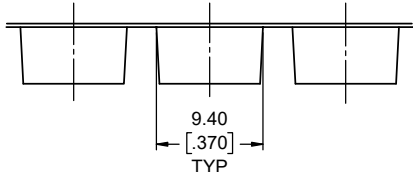
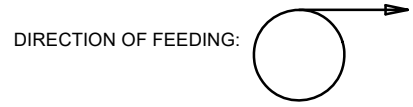

UNLESS SPECIFIED OTHERWISE	DRAWN	C. ZHANG	MAY05/22
PRIMARY UNITS MILLIMETRES	CHECKED		
SECONDARY INCHES	M.E. APP'D		
REFERENCE IN PARENTHESES	Q.A. APP'D		
GENERAL TOLERANCES	DWG APPR.	C. ZHANG	SEP07/22
1 DECIMAL PLACE ±0.30	ENG. REL. NO.	EAR 15077	
2 DECIMAL PLACES ±0.10	REF.		
3 DECIMAL PLACES	THIRD ANGLE PROJECTION		
ANGULAR DEGREES	DO NOT SCALE DRAWING		

**Amphenol Canada Corp.**  
Commercial Products

FLT SERIES, SMD  
TERMINAL BLOCK - 2 POLES  
RoHS COMPLIANT

DWG. NO. **P-FLT-S22WR-00** REV **E**

CODE ID NO. 03554 DWG SIZE: X SCALE: 6:1 SHEET 2 OF 2