

89G B98 7 8-A 9BGCB98
 -B'A @A 9HFGGB7 < 9GQ

: ± "%
 G9A !%\$\$!\$&!\$" "L!LL!8 G< C K B

G9A !%L!LL!LL "L!LL!8!LL!LL

Bc C: DC GHC BG
 !\$) H:FI 1) \$ fD9f 'C K Ł
 fIB) 'DC G-B 7 F9A 9B HŁ

@5 8 G M @
 !& 'G F: 5 7 9 A C I B H

G H 7 ? < 9 ± < H
 !\$ " . " ' A A

D @ HB: GD97 ± 7.5 HC B
 ! < . < 9 5 J M " \$ \$ \$ \$ \$ ' \$; C @ ' C B ' <
 " " " 7 C B H 5 7 H Z ; C @ 8 : @ 5 G < C B ' H 5 @
 ! : ; C @ 8 Z " \$ \$ \$ \$ \$; C @ 8 ' C B ' 7 C B H 5 7 H
 " ; C @ 8 : @ 5 G < C B ' H 5 @
 ! : ; @ 5 G < Z " \$ \$ \$ \$ \$ ' C B ' 9 B H F 9 7 C B H 5 7 H

C DHC B
 !H . H 5 D9 / ' F 99 @
 !? . DC @ M A - 8 9 : - @
 " " " f l G 9 ? !) \$ \$! ' \$ \$ Z G 99 : ± ") Z G < H & Ł

C DHC B
 ! 5 . 5 @ . BA 9 B H D B f G 99 : ± " & Z G < 99 H & Ł
 " " " " f B C H 5 J 5 - @ 6 @ K # k ! @ ' C F ! K H Ł
 ! @ . : @ 7 ? - B : ' 7 @ D f G 99 : ± " " Z G < 99 H & Ł
 " " " f B C H 5 J 5 - @ 6 @ K # k ! 5 C F ! K H Ł
 ! K H K 9 @ 8 H 5 6 f G 99 : ± " (Z G < 99 H & Ł
 " " " f B C H 5 J 5 - @ 6 @ K # k ! 5 C F ! @ Ł

F C K ' GD97 ± 7.5 HC B
 ! 8 . 8 C I 6 @ F C K

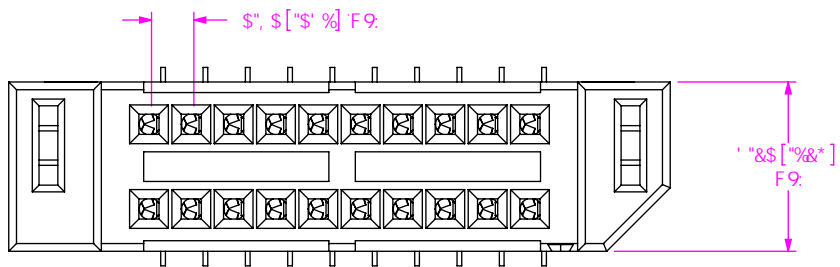

\$, \$["\$ %] F9.

"&\$["%&*" F9.

fBc C: DC G I " % & ! " \$, \$ \$ E [" \$ ' %]
 fHC @ B C B ' 5 7 7 I A Ł
 f B C H G M A 9 H F 7 5 @

LEAD STYLE	ASSEMBLY OPERATION	START-UP INSPECTION CODE A	IN PROCESS INSPECTION CODE B
-02	FILL C-241	C1, C2, C3, C4, C5	C6, C7
-02	FILL WT-36		C8, C9
-02	FILL LC-06		C10, C11
-02	ADD KAPTON PAD		

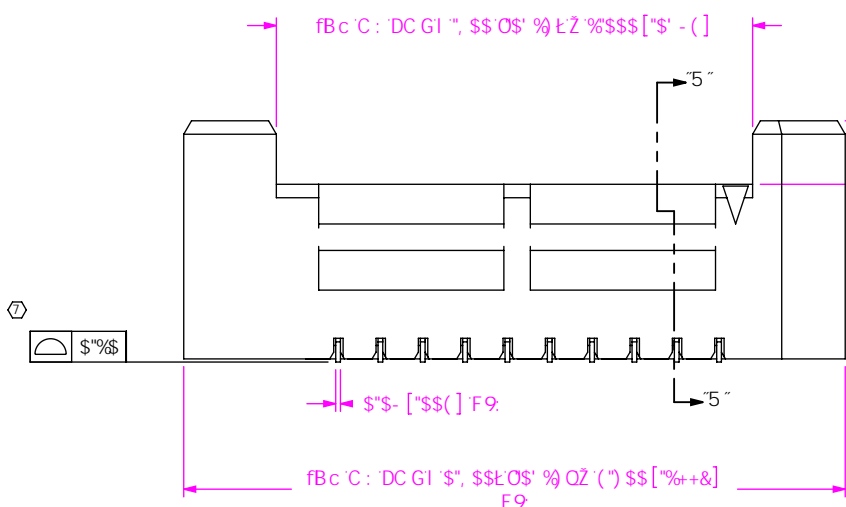

fBc C: DC G I " , \$ \$ ' O S ' %) Ł Z % \$ \$ \$ [" \$ ' - ()

" " \$ ["% \$] F9.
 (") \$ ["% + +] F9.

" \$ \$ - [" \$ ()] F9.

fBc C: DC G I " \$, \$ \$ E [" \$ ' %) O Z ' (") \$ \$ [" % + &]
 F9.

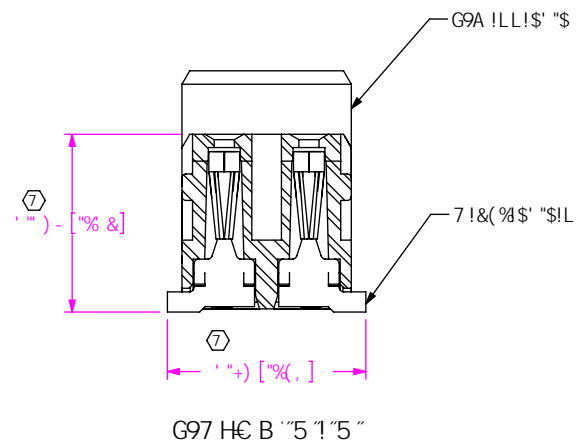

G97 HC B " 5 1 5 "

I B @ 9 G ' C H : 9 F K - G 9 ' GD97 ± 9 8 2
 8 A 9 B G C B G 5 F 9 - B ' A - @ A 9 H F G '
 H C @ 9 F 5 B 7 9 G ' 5 F 9 .
 8 9 7 A 5 @ G 5 B : @ 9 G
 L " L . ± \$ " " O S % O & *
 L " L L . ± \$ \$ % O S \$) O
 L " L L L . ± \$ \$) % O S \$ & \$ Q



) & \$ D 5 F ? 9 5 G H 6 @ 8 2 B 9 K 5 @ 5 B M Z B (+) \$
 D < C B 9 : % & - ((1 * + ' : : 5 L . : % & - (. !) \$ (+
 Y I A U J : } z : 4 G 5 A H 7 ' W z : a " " " " " W z X Y .)) & "

A 5 H F 5 @ 8 C ' B C H G 7 5 @ 9 8 F 5 K B : G : 9 9 H G 7 5 @ 9 : + % # G @ H C F : J 9 7 H 5 9 % \$] 7 C B H 5 7 H , &) 6 Y 7 1 Z < 5 @ ' < 5 F 8 @ C 7 ? - B : 7 @ D . D < C G 6 F C B 9) % \$ K 9 @ 8 H 5 6 ' 6 F 5 G 5 @ @ C K & ' S 2 : 1 @ @ < 5 F 8	8 9 6 7 F D H C B . " , A A ' H : 9 F ' 9 M 9 A 7 F C ' G C 7 ? 9 H 8 K : " " B C " G9A !%L!LL!LL "L!LL!8!LL!LL 6M 6'F5M %\$!% !&\$ \$+ G< 99H% C : &
---	--

F9J €€ B '5

G9A !%&!\$&\$" "\$!LL!8!5 'G<C K B

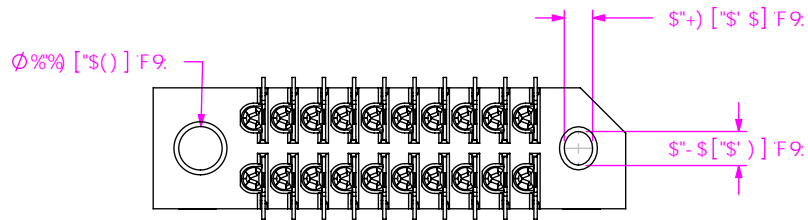
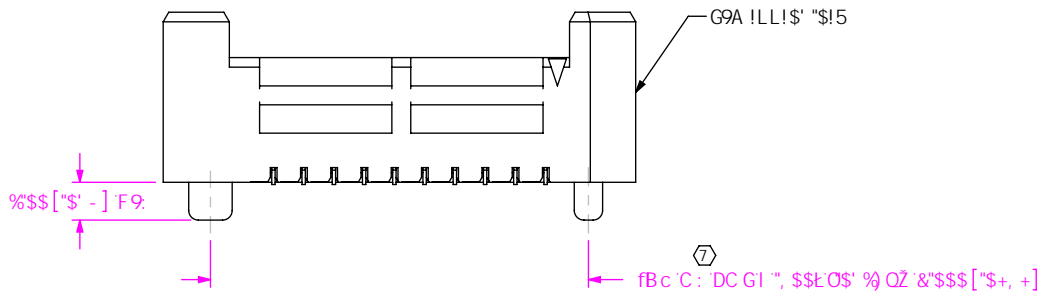

G9A !%&!\$&\$" "\$!LL!8!K HG<C K B

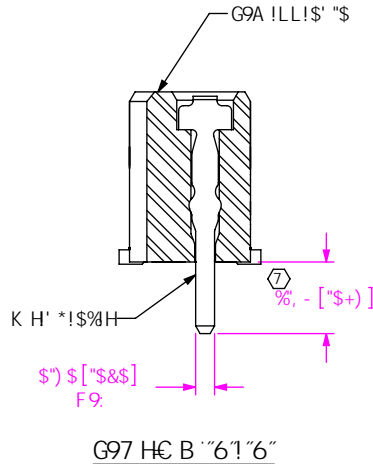
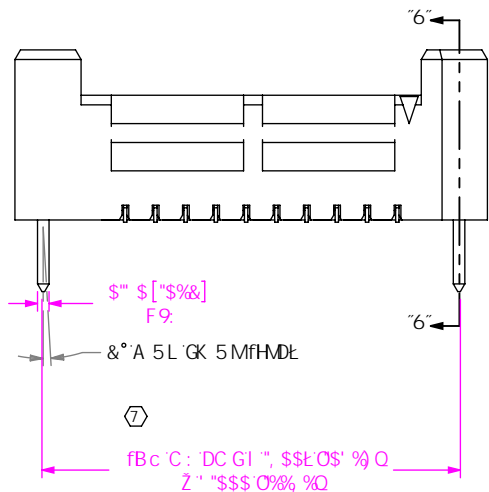

G9A !%&!\$&\$" "\$!LL!8!@ 'G<C K B

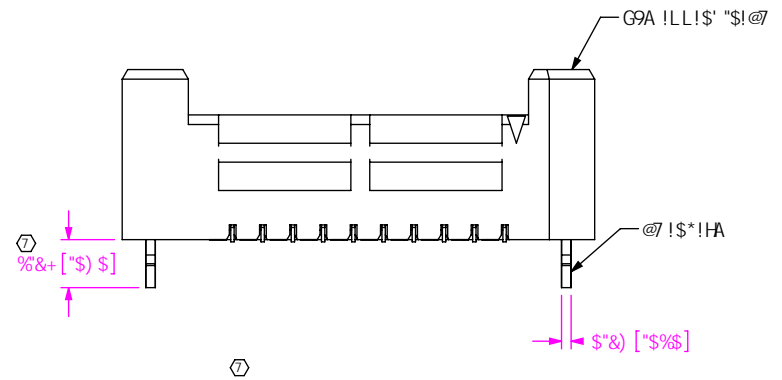

G9A !%&!\$&\$" "\$!LL!8!?' 'G<C K B

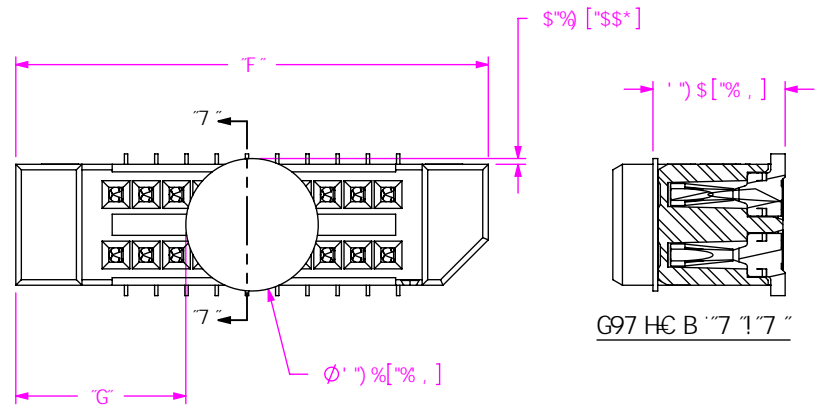

BC HR: "F" 1 C J 9 F 5 @ @ 9 B; H: "F 9 L
" G 1 d r F " ! ") % 0 % , @ # & O \$ + , + Q - \$ " % O \$ & O

DFC DF 9 H 5 FMBC H 9
H: € BC 7 1 A 9 8 H 7 C B H 6 B G B C F A 5 H C B
7 C B: € 9 8 H 5 B 8 D F C D F 9 4 5 F M C
GSA H 7 2 8 7 5 B 8 G 5 8 8 H 6 9 F 9 0 F C 8 1 7 9 8
C F H F 5 B G 9 F 9 8 H C H: 9 F 8 C 7 1 A 9 8 H C F
8 4 7 8 C 9 8 H C H: 9 F G C F 1 9 8: C F 5 B M
D I F D C 9 9 C H: 9 F H: 5 B H: 5 H K < 7 < H K 5 G
C 6 H 5 B 9 8 K H: C I H H: 9 9 L D F 9 0 9 8 K F H 9 8
7 C B G 9 8 H C: GSA H 7 2 8 7 "

8 C B C H G 7 5 @ 9 8 F 5 K B:

G: 9 9 H 7 5 @ 9) %

samtec

) & \$ D 5 F ? 9 5 G H 6 @ 8 Z B 9 K 5 @ 5 B M B (+) \$
D < C B 9 ; % & L - ((! * + " # \$ % & ' () * +
Y I A U J ; } z 4 G S A H 7 " W c a " " W X Y .) ' & &

8 9 G 7 F 8 H C B:

" , A A ' H 9 F 9 M 9 A 7 F C ' G C 7 ? 9 H

8 K : " B C "

G9A !%&!\$&\$" "\$!LL!8!LL" LILL!8!LL!LL

6M 6 F 5 M %&!% !&\$ \$ + G< 9 9 H & C : &