

DO NOT SCALE FROM THIS PRINT

UNLESS OTHERWISE NOTED		TOLERANCES ARE:	TITLE: 2mm	DWG NO:
ONE PLACE DECIMALS ±.1 [2.5mm]	THREE PLACE DECIMALS ±.005 [0.13mm]	ANGLES ± 2°	TERMINAL STRIP ASSEMBLY (R/A)	TMM-1XX-XX-XX-X-RA-XXX
TWO PLACE DECIMALS ±.010 [0.25mm]	FOUR PLACE DECIMALS ±.0020 [0.05mm]			SHEET 1 OF 1

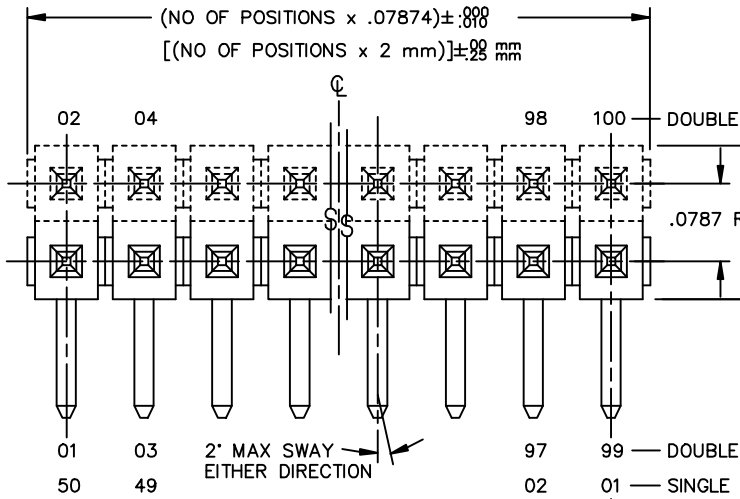

TMM-1XX-XX-XX-X-RA-XXX

NO. OF POSITIONS PER ROW
-01 THRU -50

OPTION
POLARIZATION
SPECIFY POS -XXX AS POS TO BE OMITTED

OPTION
-RA: RIGHT ANGLE

BODY SPECIFICATION
-S: SINGLE (TMM-50-S)
-D: DOUBLE (TMM-50-D)

TERMINAL SPEC
-01: USE T-1S13-XX-X-2

PLATING SPECIFICATION
-G: GOLD (SPECIFY -G IN TERMINAL SUFFIX -X)
-T: TIN (SPECIFY -T IN TERMINAL SUFFIX -X)
-S: SELECTIVE GOLD (SPECIFY -S IN TERMINAL SUFFIX -X)
-L: LIGHT SELECTIVE GOLD (SPECIFY -L IN TERMINAL SUFFIX -X)
-F: FLASH SELECTIVE GOLD (SPECIFY -F IN TERMINAL SUFFIX -X)
-H: HEAVY GOLD (SPECIFY -H IN TERMINAL SUFFIX -X)
-TM: MATTE TIN (SPECIFY -T IN TERMINAL SUFFIX -X)
-LM: LIGHT SELECTIVE GOLD/MATTE TIN TAIL (SPECIFY -L IN TERMINAL SUFFIX -X)
-FM: FLASH GOLD/MATTE TIN TAIL (SPECIFY -F IN TERMINAL SUFFIX -X)
-SM: SELECTIVE GOLD/MATTE TIN TAIL (SPECIFY -S IN TERMINAL SUFFIX -X)

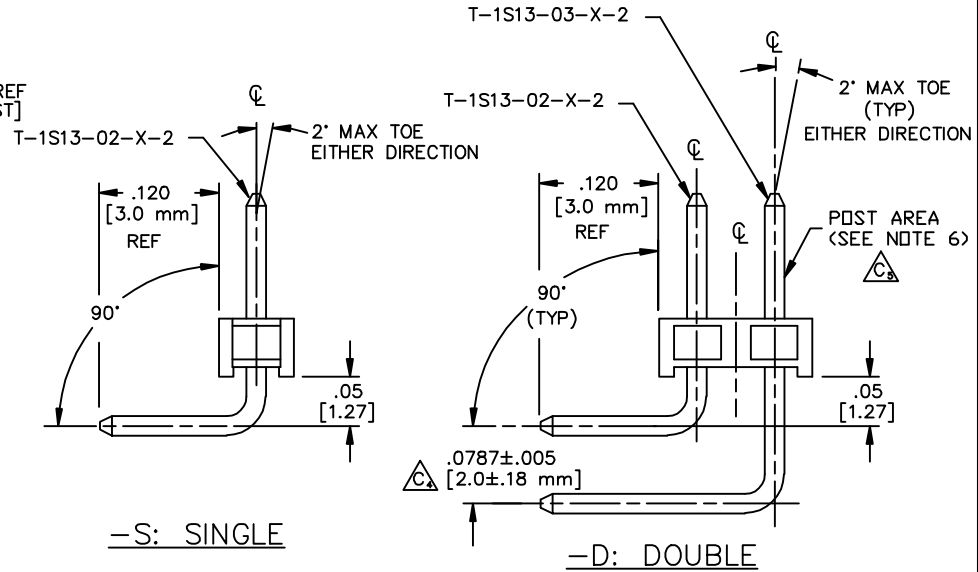
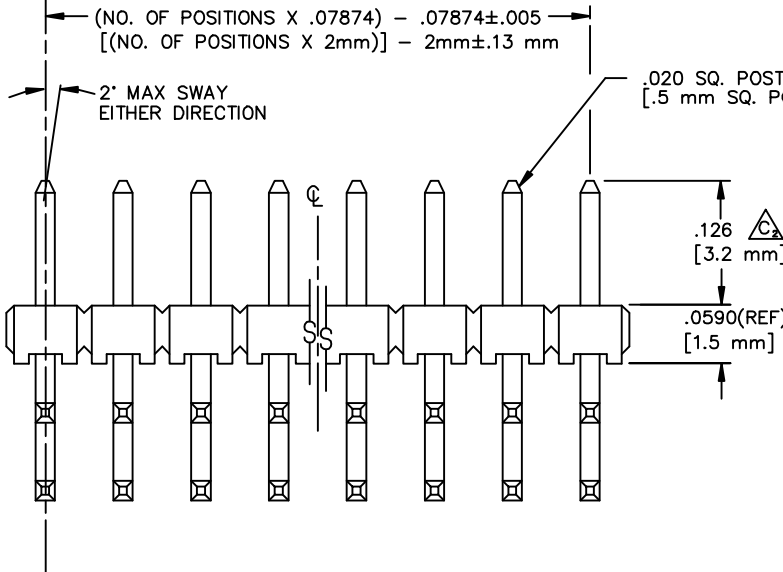

- NOTES:
1. MAX. ALLOWABLE BOW: .005 IN/IN AFTER ASSEMBLY.
 2. MAX. PIN ROTATION IN BODY: 2°
 3. PUSHOUT FORCE SHALL BE 1 lb MIN.
 4. Ⓢ REPRESENTS A CRITICAL DIMENSION FOR STATISTICAL PROCESS CONTROL USE.
 5. ALL DIMENSIONS IN BRACKETS [] TO BE MILLIMETERS.
 6. NO BANDOLIER MARKS ARE ALLOWED IN THE POST AREA.
 7. MAX CUT FLASH: .010 [0.25]

PROPRIETARY NOTE
THIS DOCUMENT CONTAINS INFORMATION CONFIDENTIAL AND PROPRIETARY TO SAMTEC INC AND SHALL NOT BE REPRODUCED OR TRANSFERRED TO OTHER DOCUMENTS OR DISCLOSED TO OTHERS OR USED FOR ANY PURPOSE OTHER THAN THAT FOR WHICH IT WAS OBTAINED WITHOUT THE EXPRESSED WRITTEN CONSENT OF SAMTEC INC.

EXISPROD\ASSEMBLY\2mm TMM-RA

samtec

520 PARK EAST BLVD. NEW ALBANY, INDIANA 47150
PHONE (812) 944-6733 P.O. BOX 1147
CODE 55322

MADE BY: REIDINGER 5-22-91
CHECKED BY: McCARTIN

ENG. APPROVAL
DEM

TMM-1XX-XX-XX-X-RA-XXX
SHEET 1 OF 1