

DO NOT SCALE FROM THIS PRINT

DESIGNED & DIMENSIONED IN MILLIMETERS [INCHES]

SCRU-XX

STYLE
 -01: USE SCRUA-S-01 (SEE FIG. 1, SHT 1)
 -02: USE SCRUA-S-02 (SEE FIG. 2, SHT 2)

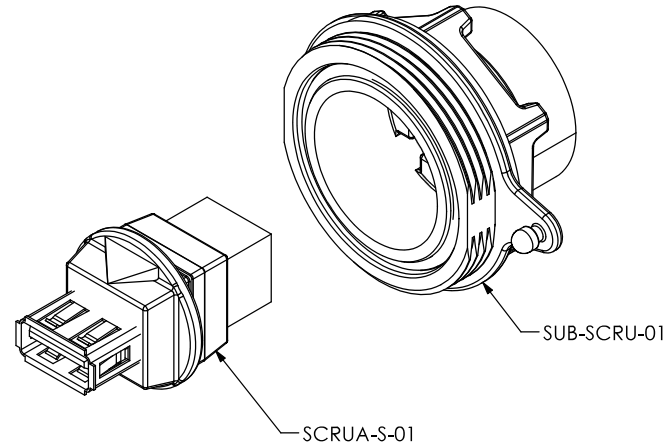
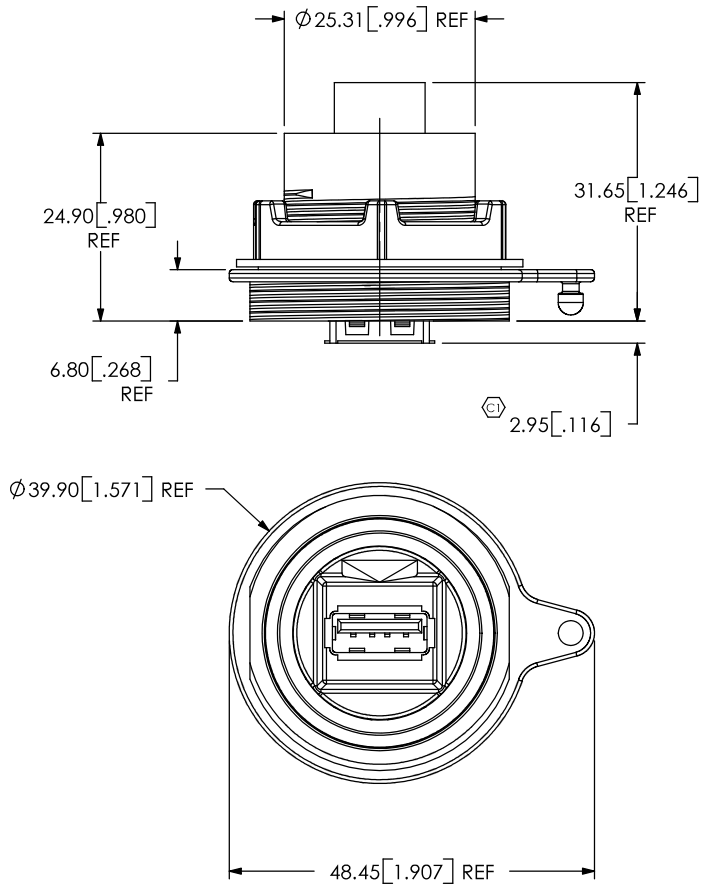

RECOMMENDED PANEL HOLE FOR -01 & -02 STYLES (SEE NOTE 3)

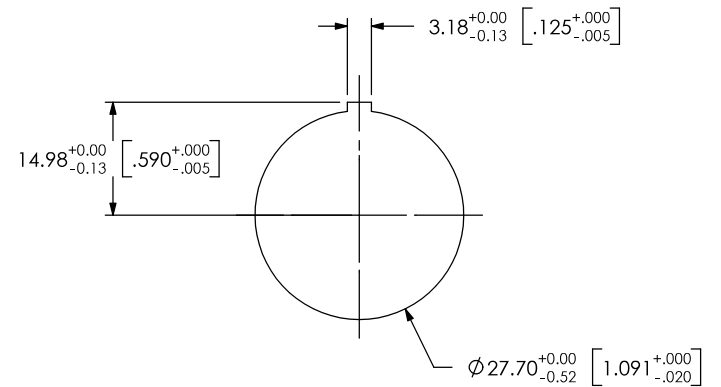
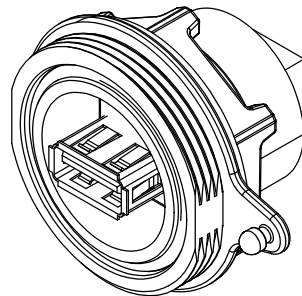

FIG. 1 (SCRU-01 SHOWN)



- NOTES:
1. REPRESENTS A CRITICAL DIMENSION.
 2. ASSEMBLY TO MEET UL 94V-O.
 3. PANEL THICKNESS: 0.8[.03] - 5.2[.205].

F:\DWG\MISC\MKTG\SCRU-XX-MKT.SLDDRW

UNLESS OTHERWISE SPECIFIED, DIMENSIONS ARE IN MILLIMETERS. TOLERANCES ARE:
 DECIMALS ANGLES
 .X: ±0.3 [.01] 2°
 .XX: ±0.13 [.005]
 .XXX: ±0.051 [.0020]

PROPRIETARY NOTE

THIS DOCUMENT CONTAINS INFORMATION CONFIDENTIAL AND PROPRIETARY TO SAMTEC, INC. AND SHALL NOT BE REPRODUCED OR TRANSFERRED TO OTHER DOCUMENTS OR DISCLOSED TO OTHERS OR USED FOR ANY PURPOSE OTHER THAN THAT WHICH IT WAS OBTAINED WITHOUT THE EXPRESSED WRITTEN CONSENT OF SAMTEC, INC.

SAMTEC

520 PARK EAST BLVD. NEW ALBANY, IN 47150
 * PHONE: 812.944.6733 FAX: 812.948.5047
 e-Mail: INFO@SAMTEC.COM CODE: 55322

MATERIAL: OR-17-01: SILICONE DO NOT SCALE DRAWING SHEET SCALE: 1:1
 PMB-17-01: PA66
 SPC-17-01: SILICONE
 SPN-17-01: PA66
 SCRUA-XX INSULATOR: PBT
 SCRUA-XX CONTACTS: PHOS BRONZE
 SCRUA-XX SHIELDS: PHOS BRONZE
 SCRUA-XX OVERMOLD: PBT



DESCRIPTION: USB PANEL MOUNT ASSEMBLY
 DWG. NO. SCRUA-XX
 BY: CHAD F 12/13/2004 SHEET 1 OF 2

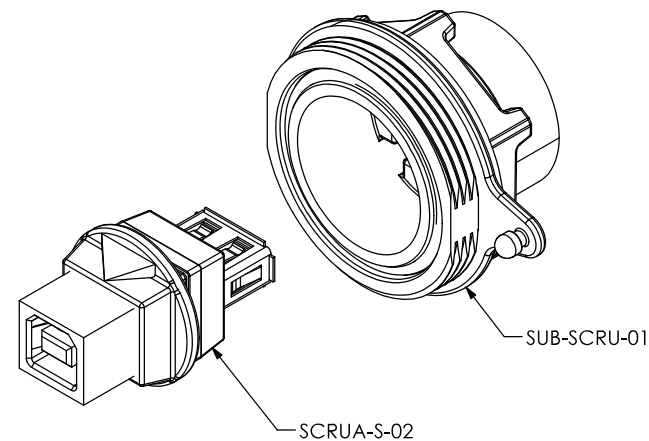
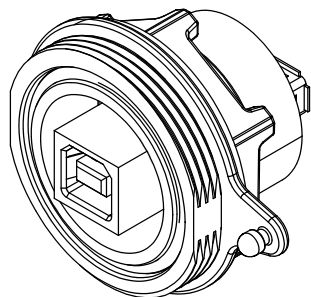
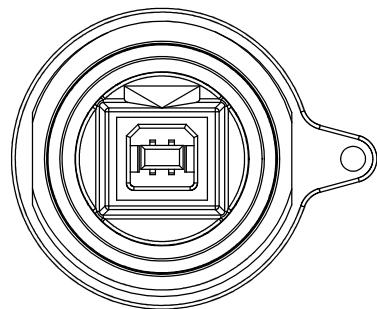
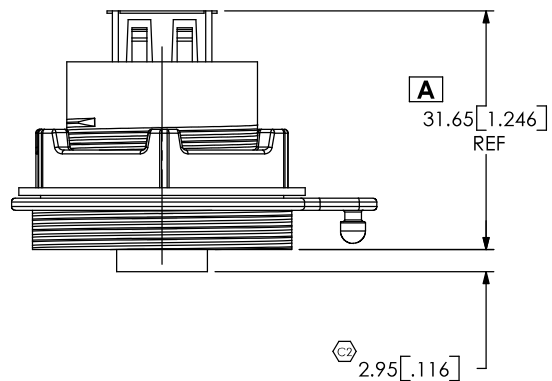

FIG. 2
(SCRU-02 SHOWN)
(SAME AS FIG. 1, UNLESS OTHERWISE STATED)

PROPRIETARY NOTE

THIS DOCUMENT CONTAINS INFORMATION CONFIDENTIAL AND PROPRIETARY TO SAMTEC, INC. AND SHALL NOT BE REPRODUCED OR TRANSFERRED TO OTHER DOCUMENTS OR DISCLOSED TO OTHERS OR USED FOR ANY PURPOSE OTHER THAN THAT WHICH IT WAS OBTAINED WITHOUT THE EXPRESSED WRITTEN CONSENT OF SAMTEC, INC.

DO NOT SCALE DRAWING

SHEET SCALE: 1:1

SAMTEC

520 PARK EAST BLVD, NEW ALBANY, IN 47150
* PHONE: 812.944.6733 FAX: 812.948.5047
e-Mail: INFO@SAMTEC.COM CODE: 55322

DESCRIPTION: USB PANEL MOUNT ASSEMBLY

DWG. NO. SCRU-XX

BY: CHAD F 12/13/2004 SHEET 2 OF 2