

NOTES

- MATERIAL** (ABS) FLAME RETARDANT UL94 VO MATERIAL WITH BRASS INSERTS IN CORNER POSTS.
(STYRENE) IS NON-FLAME RETARDANT WITHOUT BRASS INSERTS.
- PARTS** (ABS) VERSION MACHINE SCREWS M3-0.5 x 10mm.
REPLACEMENT PN 1591MS100 (100 / BAG). (STYRENE) VERSION SELF TAPPING #4 x 0.5".
REPLACEMENT PN 1599TS100BK (100 / BAG).
- COLORS** (ABS) BLACK, GRAY, BLUE, & BEIGE, (STYRENE) BLACK ONLY.

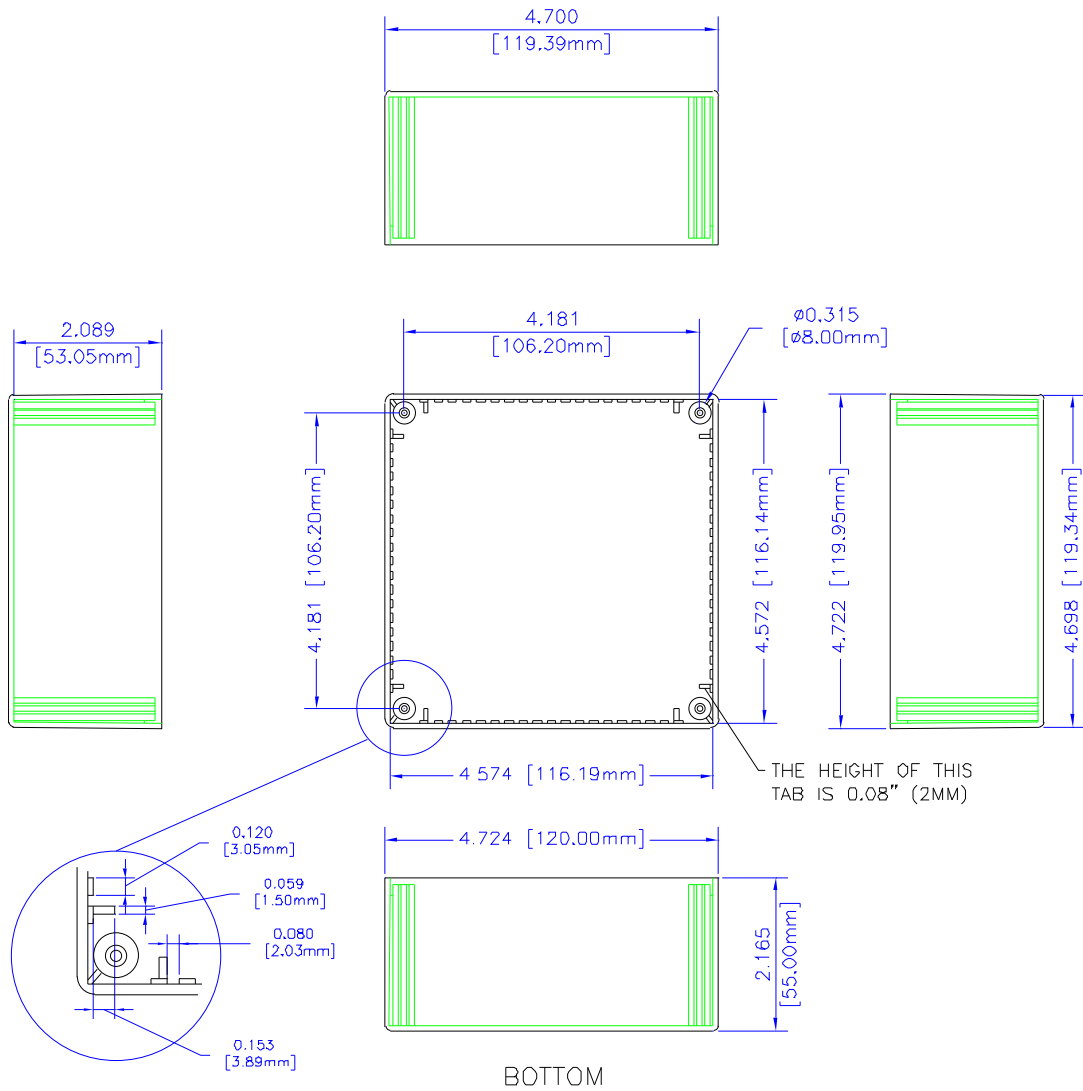

THE HEIGHT OF THIS TAB IS 0.08" (2MM)

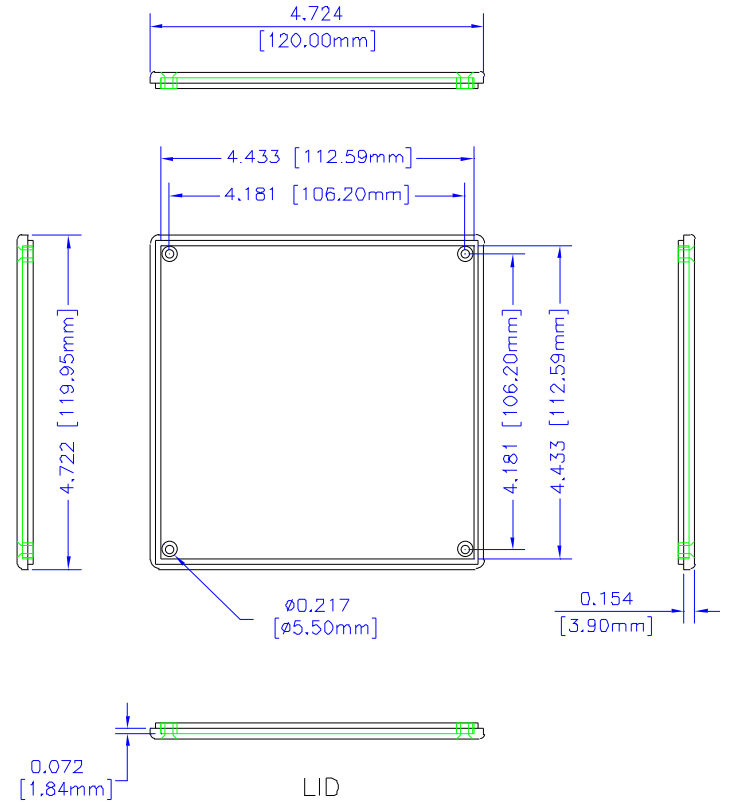

LID

UNLESS OTHERWISE SPECIFIED
DIMENSIONS ARE IN INCHES
X +/- .1
XX +/- .06
XXX +/- .015
DITS +/- .003
ANGLES +/- .5 DEG

NOTICE
HAMMOND MANUFACTURING RESERVES THE RIGHT TO
CHANGE OR REVISE THIS DRAWING AT ANY TIME
WITHOUT NOTICE. THIS DRAWING IS A REFERENCE FOR
ENGINEERING INFORMATION ONLY. THIS
INFORMATION MAY NOT BE USED TO
MANUFACTURE PRODUCT WITHOUT WRITTEN
PERMISSION FROM HAMMOND MANUFACTURING.



HAMMOND
MANUFACTURING

WEB: WWW.HAMMONDMFG.COM

TITLE		HAMMOND 1591 SERIES PLASTIC ENCLOSURE	
DRAWN BY	MJM	DATE	08/20/00
SCALE		PAGE	1 OF 1
PART NUMBER	1591U		