

VANDAL
RESISTANT

SERIES 76-59



SERIES 76-59

FEATURES

- Vandal resistant
- Panel sealed to IP67
- Non – rotating button
- Machined from stainless steel
- Wide temperature range of -30°C to + 105°C
- Gold contacts
- Solder terminals

NON-STANDARD OPTIONS

- PCB terminals
- Illumination
- Engraving
- Tailored to suit your requirements

The 76-59 Series of push-button switches are extremely rugged making them particularly suited to applications in which vandal resistance is a necessity. The switch body and buttons are machined from hard-wearing stainless steel and come in a front mounting style. The 76-59 Series all provide momentary action and are based on our proven Series 59 push buttons. Connections are made via the solder terminal at the rear of the switch.

TECHNICAL

MECHANICAL

Operating force	3N (typical)
Panel thickness	1,5 mm to 8 mm
Body Diameter	M19 thread
Panel cut out	Ø 19,25 mm
Life (min)	1,000,000 cycles
Travel	2.3 mm

ELECTRICAL

Dielectric strength	1KV AC 1 minute
Insulation resistance	1GΩ @500V d.c
Contact resistance (initial)	50mΩ
Electrical load	Current rating, typical @ 32 VAC resistive: 400mA @ 50 VDC resistive: 100mA @ 125 VAC resistive: 125mA
Life	500,000 cycles (max load) @ 70°C

ENVIRONMENTAL AND PHYSICAL

Ingress protection	IP67 (Panel Sealing)
Operating temperature range	-30°C to + 105°C
Body material	Stainless steel
Actuator material	Stainless steel
Contact material	Gold plated, nickel
Terminal material	Brass, 5µm bright acid tin plate, nickel flash undercoat.

APPLICATIONS

- Vandal resistant and robust industrial requirements
- Flush-with-panel installation requirement
- Railway carriage equipment
- Elevators
- Earth moving equipment
- Medical instrumentation
- Process control
- External security door controls
- Fishing vessels
- Crane gantry equipment
- Upper deck yachting equipment

ORDERING

BUTTON STYLE

Flush - 1

MOUNTING

Front panel - 15 mm button - 0

LED COLOUR

Red R
Green G
Blue B

(This digit only required for illuminated part numbers)

PANEL MOUNTING AND CONSTRUCTION INFORMATION

The 76-59 series mounts from the front into a 19,25 mm diameter panel cut out. Panel sealing is achieved by means of a sealer washer which is fitted to the switch body before it is inserted into the panel hole. The switch is then held in place by a lock-nut screwed on from the rear.

CIRCUIT FORM



PANEL MOUNTING DIAGRAMS

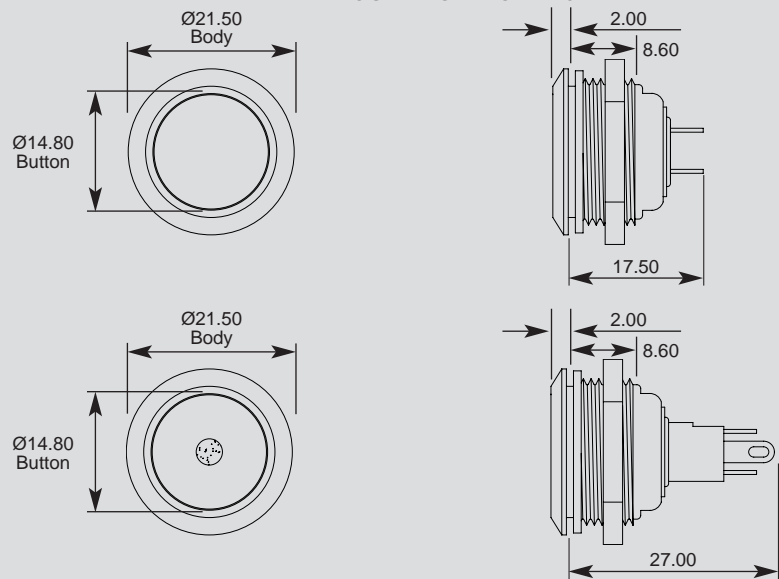

INGRESS PROTECTION IMPACT KEY

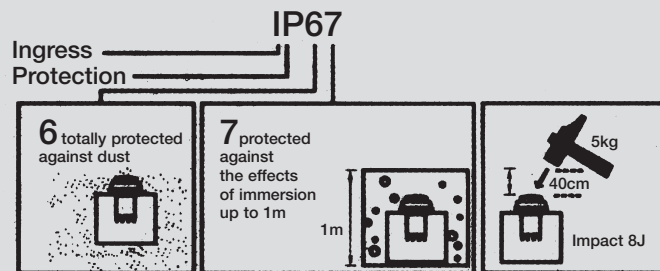

FURTHER INFORMATION

ITW Switches

A Division of ITW Limited
Norway Road, Portsmouth,
England PO3 5HT
Tel: 00 44 (0) 2392 656200
Fax: 00 44 (0) 2392 666352

e-mail:
info@itwswitches.co.uk

website:
www.itwswitches.co.uk

ITW Switches
ITW Switchpanels

SERIES 76-59