



PART NO.

2UB3001-W05102

REVISIONS

ECN #	REV	DESCRIPTION	DRAWN	DATE	CHECKD	DATE	APPRVD	DATE
-	A	RELEASED	Sidhu	03/02/11	Jagan	03/02/11	Farnell	17/02/11

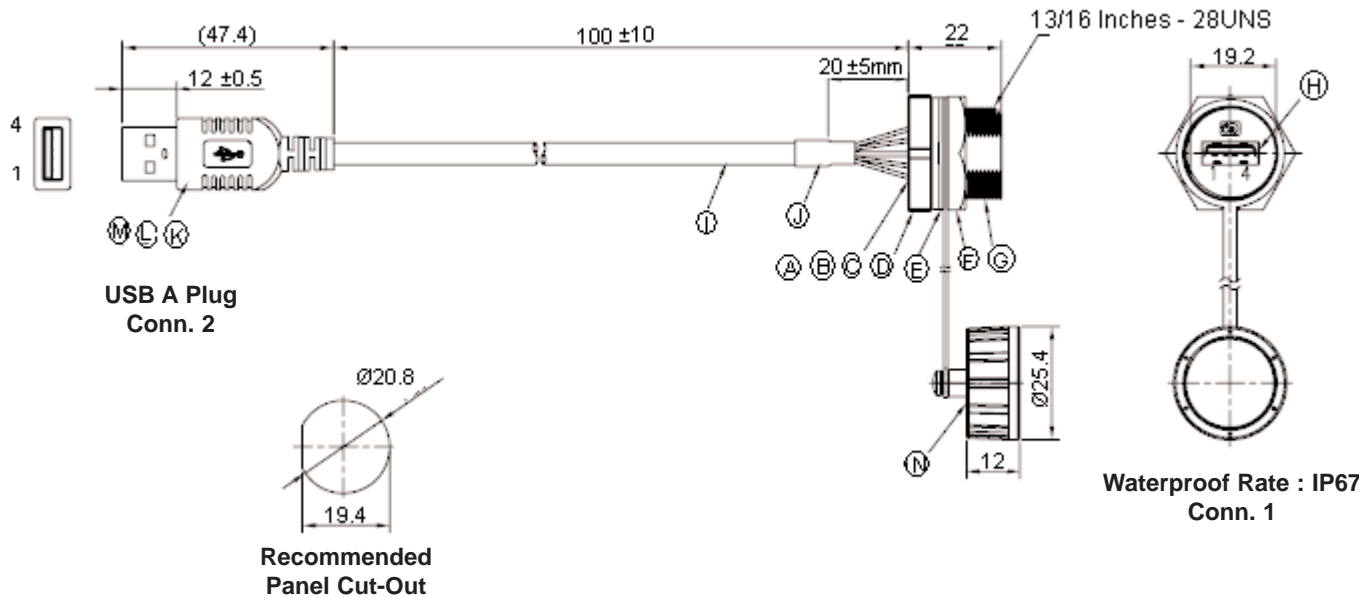

Waterproof Rate : IP67  
Conn. 1

Dimensions : Millimetres

Specifications:

- Waterproof rate : IP67.
- IP67 : Immersed in 1M water for 30 minutes.
- Rating : 30V 1A.
- Specifications : see USB series specifications.
- To conform to singatron hazardous substance free specifications.
- Maximum for panel thickness : 2.5mm.

This data sheet and its contents (the "Information") belong to the Premier Farnell Group (the "Group") or are licensed to it. No licence is granted for the use of it other than for information purposes in connection with the products to which it relates. No licence of any intellectual property rights is granted. The Information is subject to change without notice and replaces all data sheets previously supplied. The Information supplied is believed to be accurate but the Group assumes no responsibility for its accuracy or completeness, any error in or omission from it or for any use made of it. Users of this data sheet should check for themselves the information and the suitability of the products for their purpose and not make any assumptions based on information included or omitted. Liability for loss or damage resulting from any reliance on the Information or use of it (including liability resulting from negligence or where the Group was aware of the possibility of such loss or damage arising) is excluded. This will not operate to limit or restrict the Group's liability for death or personal injury resulting from its negligence. SPC MULTICOMP is the registered trademark of the Group. © Premier Farnell plc 2011.

TOLERANCES:  
UNLESS OTHERWISE SPECIFIED, DIMENSIONS ARE FOR REFERENCE PURPOSES ONLY.

DRAWN BY:	DATE:
Sidhu	03/02/11
CHECKED BY:	DATE:
Jagan	03/02/11
APPROVED BY:	DATE:
Farnell	17/02/11

DRAWING TITLE:			
Waterproof USB2.0 Jack to USB Plug			
SIZE	DWG NO.	ELECTRONIC FILE	REV
A	M10002805	2UB3001-W05102	A
SCALE: NTS		U.O.M.: mm	SHEET: 1 OF 3



PART NO.

2UB3001-W05102

REVISIONS

ECN #	REV	DESCRIPTION	DRAWN	DATE	CHECKD	DATE	APPRVD	DATE
-	A	RELEASED	Sidhu	03/02/11	Jagan	03/02/11	Farnell	17/02/11

Pin out

Conn. 2

Conn. 1

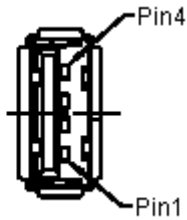

Pin Assignments Front View

Shield	Drain	Shield
Conn. 2	Wire Colour	Conn. 1
1	Red (24AWG)	1
2	White (28AWG)	2
3	Green (28AWG)	3
4	Black (24AWG)	4

This data sheet and its contents (the "Information") belong to the Premier Farnell Group (the "Group") or are licensed to it. No licence is granted for the use of it other than for information purposes in connection with the products to which it relates. No licence of any intellectual property rights is granted. The Information is subject to change without notice and replaces all data sheets previously supplied. The Information supplied is believed to be accurate but the Group assumes no responsibility for its accuracy or completeness, any error in or omission from it or for any use made of it. Users of this data sheet should check for themselves the Information and the suitability of the products for their purpose and not make any assumptions based on information included or omitted. Liability for loss or damage resulting from any reliance on the Information or use of it (including liability resulting from negligence or where the Group was aware of the possibility of such loss or damage arising) is excluded. This will not operate to limit or restrict the Group's liability for death or personal injury resulting from its negligence. SPC MULTICOMP is the registered trademark of the Group. © Premier Farnell plc 2011.

TOLERANCES:

UNLESS OTHERWISE SPECIFIED, DIMENSIONS ARE FOR REFERENCE PURPOSES ONLY.

DRAWN BY:	DATE:
Sidhu	03/02/11
CHECKED BY:	DATE:
Jagan	03/02/11
APPROVED BY:	DATE:
Farnell	17/02/11

DRAWING TITLE:

Waterproof USB2.0 Jack to USB Plug

SIZE A	DWG NO. M10002805	ELECTRONIC FILE 2UB3001-W05102	REV A
SCALE: NTS	U.O.M.: mm	SHEET: 2 OF 3	



PART NO.

2UB3001-W05102

REVISIONS

ECN #	REV	DESCRIPTION	DRAWN	DATE	CHECKD	DATE	APPRVD	DATE
-	A	RELEASED	Sidhu	03/02/11	Jagan	03/02/11	Farnell	17/02/11

Specifications Table

Description	Material	Plating and Colour
PCB	FR-4	Green
O-Ring	EPDM	Black
Thermal Glue	-	Natural
Sealing Nut	PPE	Black
Gasket	EPDM	
Screw Nut	PPE	
Housing	PPE	N/A
USB A Jack	P/N:2UB1518-000111	
Cable	USB2.0 28#*1P+24#*2C+ADB,UV Resistant	
Shrink Tube	Ø5*15	Black
Over Mold	PVC	N/A
AL Foil	AL Foil	
USB Plug	USB2.0 Pulg	
Waterproof Cap	P/N:2UB3001-W0000W	

Part Number Table

Description	Part Number
Adapter, USB Jack - Plug, Cable	2UB3001-W05101

<http://www.farnell.com>

<http://www.newark.com>

<http://www.cpc.co.uk>

This data sheet and its contents (the "Information") belong to the Premier Farnell Group (the "Group") or are licensed to it. No licence is granted for the use of it other than for information purposes in connection with the products to which it relates. No licence of any intellectual property rights is granted. The Information is subject to change without notice and replaces all data sheets previously supplied. The Information supplied is believed to be accurate but the Group assumes no responsibility for its accuracy or completeness, any error in or omission from it or for any use made of it. Users of this data sheet should check for themselves the Information and the suitability of the products for their purpose and not make any assumptions based on information included or omitted. Liability for loss or damage resulting from any reliance on the Information or use of it (including liability resulting from negligence or where the Group was aware of the possibility of such loss or damage arising) is excluded. This will not operate to limit or restrict the Group's liability for death or personal injury resulting from its negligence. SPC MULTICOMP is the registered trademark of the Group. © Premier Farnell plc 2011.

TOLERANCES:  
UNLESS OTHERWISE SPECIFIED, DIMENSIONS ARE FOR REFERENCE PURPOSES ONLY.

DRAWN BY:	DATE:
Sidhu	03/02/11
CHECKED BY:	DATE:
Jagan	03/02/11
APPROVED BY:	DATE:
Farnell	17/02/11

DRAWING TITLE:			
Waterproof USB2.0 Jack to USB Plug			
SIZE	DWG NO.	ELECTRONIC FILE	REV
A	M10002805	2UB3001-W05102	A
SCALE: NTS		U.O.M.: mm	SHEET: 3 OF 3